



# ICE LANE TIC

2013-2014 | EXPLORE YOUR MIND





## ICELANTIC

WE ARE AN AMERICAN SKI  
COMPANY WHERE **CREATIVITY,**  
**ADVENTURE, INNOVATION**  
AND **COMMUNITY** SHAPE BOTH  
OUR APPROACH TO BUILDING  
SKIS AND LIFESTYLE.

# 1° CELSIUS



One Degree Celsius is a temperature of change—a moment when water molecules begin to crystallize into snow and ice. This transformation creates a world we love—one of snowy mountains, untracked lines and grand adventure. For us, it also represents a spirit of exploration, innovation and the potential that drives us to be who we are and do what we do.

ONE DEGREE CELSIUS!



ICELANTIC | EXPLORE YOUR MIND



ADAM ROBERTS | MT. BAKER, WA PHOTO JASON HUMMEL

ICELANTIC | 2013-2014

# EXPLORE YOUR MIND

---

## PROCESS

2013-2014 Theme.....	8
Travis Parr .....	10
Construction.....	12

---

## PRODUCTS

New SKNY Series.....	16
2013-2014 Line Up.....	18
Apparel .....	42
Ciclée Prints.....	46

---

## COMMUNITY

Winter on the Rocks ...	50
First Tracks .....	52
Pro Team .....	54
Battery 621 .....	58

---

## CONTACT

Icelantic HQ .....	62
Sales Reps.....	64









# EXPLORE YOUR MIND

ADAM ROBERTS | MT. BAKER, WA PHOTO JASON HUMMEL



## 2013-2014 **THEME**

As humans, it is our nature to explore—to ask questions and form answers—to find limits and push them. The more we question, the more we discover. The more we discover, the more we understand. However, true self-discovery takes risk, and stepping out of our comfort zone takes guts.

Ice Atlantic was born from a curiosity and willingness to cross this line. Entering into the 2013–2014 season, we continue to explore our limits—from the art on our skis (pg. 10) to the new SKNY Series (pg. 16)—and we invite and encourage you to do the same. To look from a different perspective, follow a thought you wouldn't normally follow, ski a line you've never skied before.

EXPLORE YOUR MIND



PHOTO HARRISON BUCK



## TRAVIS PARR

“This year’s direction was inspired by process and material. After creating two-dimensional paintings for Icelantic the last 7 years I choose to shift directions. The shift was to take my ideas and concepts and create three-dimensional forms—sculpture, using wood, rock, glass, plastic, shells, feathers, plants, fish, moss and hair.

This series concentrates on the ancient sense of sight and perception. Every sculpture has this foundation to it. The idea of exploring your mind has always been a big part of our survival and evolution, from the Native American owl spirit to the Northwestern totem, this journey of perception takes us to new discoveries, ideas, and ultimately to a new self-consciousness.

Art is a resource to humanities ideals and vision. It is the process and product of deliberately and creatively arranging elements in a way that appeals to the senses and emotions.

My task is to explore the many facets of the human mind. Not just the reality of the visible object but of the life it contains. The Human brain is actively seeking the structural limits of reality. It is at these limits where reality expands beyond the realm of rationality and enters the realm of wonder. By experiencing wonder, it becomes grounded in space and time, becoming part of our reality. It is here, at this crux of science and art that I choose to take action. I am committed to exploring the structure of wonder and deliver my results to you.”

**PARR.**



## MAKE LOCAL, **THINK GLOBAL**

Every one of Icelantic's bomb-proof skis are made by hand in Denver, Colorado, USA. Located 15 minutes from our office, the Never Summer Factory has been home to Icelantic manufacturing for 7 years now, continuing to produce top of the line skis with Icelantic's signature 2-Year warranty.

*Made in Colorado* is as important for Icelantic as it is beneficial. Keeping manufacturing within the State reinforces the effect and value of community and helps to keep our local economy vibrant—and stoked on snowsports!

Additionally, having the factory so close to our HQ, we can easily swing by to check on production, play with prototypes or just say hello to the awesome people building our skis.

*All of our skis come out of the factory fully tuned with a polished edge and stone finish provided by Wintersteiger.*





## CONSTRUCTION

- 1 CARBONIUM TOPSHEET MATERIAL
- 2 MATTE FIBERGLASS MOUNTING PLATE (TIERED)
- 3 UNILATERAL FIBERGLASS
- 4 DURASURF 2001 P-TEX SIDEWALL
- 5 POPLAR WOOD CORE
- 6 20 MM RUBBER FOIL (3 LAYERS)
- 7 2.2MM STEEL EDGE
- 8 ETLX 2200 TRIAXLE FIBERGLASS
- 9 DURASURF 4001 SINTERED P-TEX BASE

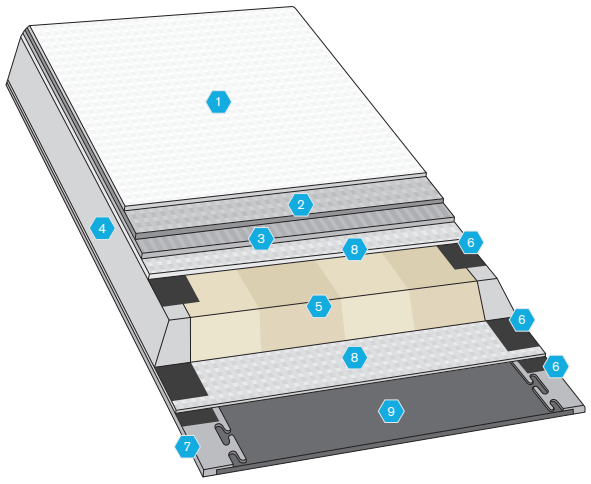







**NEW  
SERIES**





**SHAMAN**  
SKNY

**NOMAD**  
SKNY

**PILGRIM**  
SKNY

**SCOUT**  
SKNY



## SKNY SERIES

If every day were a powder day, we wouldn't have any friends. Probably wouldn't have a job either. Though that wouldn't be too bad, Icelantic understands that not everyday is a powder day, and has designed a set of tools to help you have as much fun on the days without pow, as those with.

New for 2013–2014, The SKNY Series is Icelantic's ode to carving, cruising and tackling the not-so-ideal days on-piste. Thanks to feedback from East Coasters and our European friends, we have taken the four original models, The Scout, Pilgrim, Nomad and Shaman—and put them on a diet. With the same sidecut radiuses and construction as their counterparts, The SKNY Series delivers Icelantic's top of the line quality and performance—for a whole new way of skiing... à la slope.

*Catering to the conditions in different territories.*

2013 /  
2014  
LINE UP



**GYPSY**



**SEEKER**



**KEEPER**



**SHAMAN**



**NOMAD RKR**



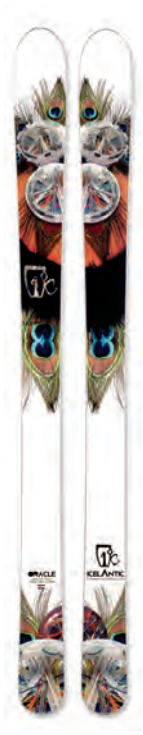

**ORACLE**



**PILGRIM**



**DA'NOLLIE**



**SCOUT**



**GEMINI**





SCOTTY VERMERRIS | BRIGHTON, UT PHOTO BRIAN PARCELLS



POWDER

## THE GYPSY

The Gypsy is a playful, bouncy, reverse camber (Rocker) ski with a friendly flex that transforms any mountain into your personal playground. With a 125 mm platform underfoot and nearly symmetrical dimensions, The Gypsy's floats through pow forward and backwards with ease. On hard-pack, The Gypsy engages the entire edge, enabling it to perform like it's on rails. This is no ordinary powder ski.

### REVERSE CAMBER



### BASE



### FLEX



### SPECS

LENGTH	170 cm	180 cm	190 cm
DIMENSIONS	152 mm x 125 mm x 148 mm		
RADIUS	19 m	22 m	25 m
WEIGHT	9.40 lbs	10.25 lbs	10.75 lbs
TIP RISE	59 cm		
TAIL RISE	51 cm		









BIG MOUNTAIN

## THE SEEKER

The Seeker is designed to go fast, make big turns, stomp air and feel secure while doing it all. It's stiff flex combined with 42 cm of early rise in the tip, a flat tail and minimum sidecut creates an explosive and solid ski that wants to be opened up.

### EARLY RISE TIP



### BASE



### FLEX

SOFT

10  
STIFF

### SPECS

LENGTH	170 cm	180 cm	190 cm
DIMENSIONS	138 mm x 112 mm x 123 mm		
RADIUS	24 m	28 m	32 m
WEIGHT	9.00 lbs	9.75 lbs	10.50 lbs
TIP RISE	42 cm		
TAIL RISE	Flat		







BIG MOUNTAIN



POWDER

## THE KEEPER

With traditional camber underfoot, The Keeper's early rise tip and tail rise to the occasion when triggered by the skier's weight. Like a hot knife through butter, this ski lets its skier float through pow, blast through crud, and scrub speed, effortlessly. With a relatively tight turning radius, The Keeper's girth is easily harnessed and abilities, endless.

### ROCKER CAMBER



### BASE



### FLEX



### SPECS

LENGTH	171 cm *	181 cm *	191 cm *
DIMENSIONS	150 mm x 119 mm x 136 mm		
RADIUS	13 m	16 m	18 m
WEIGHT	8.50 lbs	9.00 lbs	10.30 lbs
TIP RISE	35 cm		
TAIL RISE	25 cm		







ALL MOUNTAIN



CARVE



POWDER

## THE SHAMAN

The Shaman epitomizes all-mountain skiing. With its unique diamond shaped shovel, unrivaled torsional rigidity and tapered design, The Shaman harnesses its skiers strength and transforms it into a powerful, intentional turn—in any condition. Its wide tip provides flotation and direction, coupled with its significant sidecut, The Shaman is what we like to refer to as an all mountain, “Powder Carver.”

*Available in SKNY*

### TRADITIONAL CAMBER



### BASES



SKNY

### FLEX



### SPECS

LENGTH	161 cm	173 cm	184 cm
DIMENSIONS	160mm x 110mm x 130mm		
DIMENSIONS SKNY	140mm x 90mm x 110mm		
RADIUS	12m	15m	18m
WEIGHT	8.50lbs	8.80lbs	9.65lbs
WEIGHT SKNY	6.50lbs	7.00lbs	7.50lbs



SKNY





ALL MOUNTAIN

## THE NOMAD RKR

The Nomad RKR is fun. With a balanced flex, 2mm of camber underfoot and a rockered tip and tail, The Nomad RKR is a hybrid wanderer that carves, floats and butters its way down any terrain. Like most fun things, the RKR also contains an element of power and surprise—one worthy of pushing, exploring and charging. If you favor a bit of everything and want a ski that can handle anything, AND like having a good time, The RKR is the ski for you!

*Available in SKNY*

### ROCKER CAMBER



### BASES



SKNY

### FLEX



### SPECS

LENGTH	161 cm	171 cm	181 cm	191 cm*
DIMENSIONS	140mm x 105mm x 130mm			
DIMENSIONS SKNY	120mm x 85mm x 110mm			
RADIUS	13m	16m	19m	
WEIGHT	7.60lbs	8.65lbs	9.50lbs	
WEIGHT SKNY	6.00lbs	6.50lbs	7.00lbs	
TIP RISE	38cm			
TAIL RISE	32cm			



NEW

SKNY







ALL MOUNTAIN

## THE ORACLE

The Oracle is designed for women, delivering maximum performance and style with minimal effort. With Icelantic's signature "Fly-Weight" core at it's center, this ski is lighter for smaller frames, and it's slightly tapered design allows the skier to maintain a forward, aggressive stance in any condition. The Oracle's early rise tip allows its skier to float through pow and on crud, while the traditional scooped tail provides stability and predictability on-slope.

### EARLY TIP RISE



### BASE



### FLEX



### SPECS

LENGTH	155 cm	165 cm	175 cm
DIMENSIONS	138 mm x 100 mm x 120 mm		
RADIUS	13 m	16 m	18 m
WEIGHT	7.00 lbs	7.60 lbs	8.00 lbs
TIP RISE	26 cm		





BEN ANDERSON | LOVELAND SKI AREA PHOTO SAM WARREN



CARVE

## THE PILGRIM

The Pilgrim has always loved to carve. This year, it really loves to carve. Thanks to feedback from some serious railers, we've flattened The Pilgrim's tail—taking this ski to a whole new level. The Pilgrim provides stable footing at high speeds, and is well equipped to tackle early morning groomers to east coast ice with ease. If you're ready to lay some trenches, this is the ski for you.

*Available in SKNY*

### TRADITIONAL CAMBER / FLAT TAIL



### BASES



SKNY

### FLEX



### SPECS

LENGTH	159 cm	169 cm	179 cm
DIMENSIONS	127 mm x 90 mm x 115 mm		
DIMENSIONS SKNY	112 mm x 75 mm x 100 mm		
RADIUS	13 m	17 m	19 m
WEIGHT	7.15 lbs	7.45 lbs	7.85 lbs
WEIGHT SKNY	5.50 lbs	6.50 lbs	7.00 lbs



SKNY



LEIGH POWIS | DENVER, CO PHOTO JEFF NASS



PARK



URBAN

## THE DA'NOLLIE

The Da'Nollie is a park/urban ski for those looking to push the limits. Inspired and designed by pro-athlete Leigh Powis and combined with Icelantic's bomb-proof (pg. 12) construction, this ski will take your park, pipe and urban skiing to the next level. The 2013–2014 Da'Nollie contains Icelantic's "Nollie-Flex Core"—a unique core construction in which strength matches flexibility, enabling the rider to ollie, nollie butter and jib any feature—and look good while doing it.

### TRADITIONAL CAMBER



### BASE



### FLEX



### SPECS

LENGTH	160 cm	170 cm	180 cm
DIMENSIONS	118mm x 88mm x 118mm		
RADIUS	16m	18m	20m
WEIGHT	6.60lbs	7.40lbs	9.00lbs







ALL MOUNTAIN

## THE SCOUT

The Scout is exactly what you think of when you think of a Scout—curious, adventurous, playful, adaptive and tough. Holding strong since year one, The Scout remains a staple in the Icelantic line-up, serving those who desire epic versatility and performance with minimal hassle and girth. The Scout's signature stiffness, aggressive side cut and totally unique shape come together in a fast, fun and explosive skiing experience for the big-mountain groms, to the skier ready to try something out of the ordinary.

*Available in SKNY*

### TRADITIONAL CAMBER



### BASES



SKNY

### FLEX



### SPECS

LENGTH	143cm
DIMENSIONS	140mm x 105mm x 130mm
DIMENSIONS SKNY	120mm x 85mm x 110mm
RADIUS	12m
WEIGHT	7.15lbs
WEIGHT SKNY	5.00lbs



SKNY



SOUTHERN  
ISLANDS





ALL MOUNTAIN

## THE GEMINI SPLIT BOARD

Applying Never Summer's patented rocker-camber technology and bombproof construction, The Gemini is a big mountain, freestyle board with NS's Superlight wood core and extensive carbon reinforcements—backed by Icelantic's 2-Year Warranty. So all you snowboarders who've been asking us for this for years, your time has come! Get on this and get outta bounds.

NS PATENTED ROCKER CAMBER

BASE



FLEX



SPECS

LENGTH	158 cm	161 cm	163 cm
DIMENSIONS	30.00 cm x 25.40 cm x 30.00 cm		
	30.40 cm x 25.80 cm x 31.50 cm		
	31.50 cm x 26.80 cm x 31.50 cm		







ANNE LISE LOEVLE PHOTO BEN ANDERSON



ICEANTIC | PRODUCTS

# ICELANTIC APPAREL

HOODIE



CREW



SWEATPANTS



HOODIE-DRESS



FLANNEL



HENLEY



WOOL BUTTON-UP



3/4 SLEEVE



# ICELANTIC APPAREL

MISSION T



V-NECK



ASTIS MITTS



1 DEGREE SNAPBACK



5-PANEL



BEANIE



## FINE ART GICLÉE PRINTS

A Giclée (Pronounced Je-clay) is a fine art print created through an ink-jet printing process applied directly onto canvas which is then stretched, producing a replica so close to the original, even we have a hard time telling them apart.

Included with every Giclée purchase is a unique, hand-built ski hanger designed to easily mount on any wall surface to display your skis in the off season. Hang this next to your Giclée and you have an instant, one-of-a-kind, outta this world conversation piece. Your friends will be jealous.







PHOTO JEFF NASS







ICELANTIC | COMMUNITY



## WINTER ON THE ROCKS

Icelandic's Winter on the Rocks is a one-of-a kind experience held at our favorite venue in the world; Red Rocks Amphitheater. Held in conjunction with SIA's SnowShow, this benchmark event hosts a collection of Snow Sports enthusiasts, outdoor lifestyle devotees, and a variety of passionate folks celebrating winter time in Colorado and the connectivity of music, sport and fun. This annual event feature's national headlining musicians, a value-packed partner village, a custom fire feature, and plenty of energetic individuals coming together to celebrate winter lifestyle in Colorado.

For more information visit:  
[icelanticswinterontherocks.com](http://icelanticswinterontherocks.com)







## FIRST TRACKS

First Tracks is an experience-based community, rooted in passion, adventure and a love for the mountains. First Tracks was born from a curiosity to see deeper into the ongoings of Icelantic and a shared desire to connect with other like-minds. The program has grown steadily over the past four years and is now beginning to take on a life of its own. With several hundred members and many supporting sponsors, First Tracks has evolved from a single thought to a living, breathing, vibrant community of like-minded individuals coming together to enjoy life and everything it has to offer.

For more information visit:  
[firsttracks.com](http://firsttracks.com)





LEIGH POWIS | WHISTLER, BC PHOTO DAN CARR





ICELANTIC COMMUNITY





## PRO TEAM

We are fortunate to have an elite team of athletes living and breathing the energy of Icelantic while helping us create high performance skis. These athletes are creative individuals and passionate artists in their own realm and Icelantic skis are their tool to explore their full potential on the mountains as skiers.

Each athlete is instrumental in our development as a company. They show us the many ways our skis serve their drivers while helping fine tune the designs and overall schema of our brand.



### JULIAN CARR

**BIRTH PLACE**  
Salt Lake City, UT  
**LOCAL MOUNTAIN**  
Alta and Brighton, UT  
**FAVORITE SKI/QUIVER**  
Gypsy Baby!



### JOSH STACK

**BIRTH PLACE**  
Vernon, B.C.  
**LOCAL MOUNTAIN**  
Whistler B.C.  
**FAVORITE SKI/QUIVER**  
Gypsy



### LEIGH POWIS

**BIRTH PLACE**  
United Kingdom  
**LOCAL MOUNTAIN**  
Whistler/Blackcomb B.C.  
**FAVORITE SKI/QUIVER**  
Da'Nollie and Nomad RKR



### KAYLIN RICHARDSON

**BIRTH PLACE**  
Minneapolis, MN  
**LOCAL MOUNTAIN**  
Canyons Resort, UT  
**FAVORITE SKI/QUIVER**  
The Gypsy for pow, the Shaman for touring, the Pilgrim for cruising the frontside, and the Nomad RKR for when the snow is super variable. Lucky for me, I get the full line up, but I would be psyched with any of these as a single ski quiver.



PHOTO JEFF NASS



## BATTERY 621

Battery 621 or, *The Battery*, as we like to call it, is where it all happens (well, when we're not on the mountain...). As Icelantic's Headquarters, the Battery provides a work environment conducive to creativity, surrounded by success and open to the community.

Inside the walls of Battery 621 you will find world-class artists, professional athletes, unprecedented innovation, cutting-edge business methods, 3 a.m. board meetings, two wave skates and little game we like to call TrailBall (look it up).

Located on the main thoroughfare to the mountains from the city, The Battery is an ideal situation for the ski/business, ski business balance that seems to be our life.

IF YOU'RE EVER  
IN THE DENVER AREA,  
PLEASE FEEL FREE  
TO STOP IN.

621 KALAMATH STREET  
DENVER, COLORADO USA  
80204



THOR | CRESTED BUTTE, CO PHOTO CHRIS SEGAL



---

## ICELANTIC USA

### ICELANTIC HQ

621 Kalamath Street  
Denver, Colorado USA  
80204

303.670.6804 **PHONE**

303.670.6818 **FAX**

1.800.614.5230 **TOLL-FREE**

info@icelanticskis.com  
icelanticskis.com

**BEN ANDERSON** CEO | Founder  
ben@icelanticskis.com

**ANNELISE LOEVLIE** COO | International Sales  
annelise@icelanticskis.com

**TRAVIS PARR** Art Director | Artist  
parr@icelanticskis.com

**CHRIS BLACKETT** CFO  
chris@icelanticskis.com

**ASHLEY HART** Sales Manager  
Ashley@icelanticskis.com

**DUSTIN LITTLETON** Sales  
dustin@icelanticskis.com

**SAM WARREN** Events | Apparel Manager  
sam@icelanticskis.com

**SCOTTY VERMERRIS** Team Manager | Media  
scotty@icelanticskis.com

**JON MUELLER** Customer Service | Warranty  
jon@icelanticskis.com





PHOTO JEFF NASS

---

## ICELANTIC INTERNATIONAL

### ICELANTIC EUROPE LTD.

Switzerland, Germany  
Austria, Denmark

Industriestrasse 2  
7208 Malans / Switzerland  
+41 81 330 01 55 **PHONE**  
+41 81 330 01 56 **FAX**

office@icelanticeurope.com  
icelanticeurope.com

### ANDORRA

*Viladomat*  
+376 800 600  
josep@viladomat.com  
viladomat.com

### BENELUX

*White Tracks Distribution*  
+31(0)6 5589 3171  
info@whitetracks.nl  
whitetracks.nl

### ITALY

*Mt. Sports and Trading*  
+39 347 829 9585  
info@mtsport.it  
mtsport.it

### JAPAN

*Auctus Distribution*  
+81 3 3470 4163  
junji@auctus.co.jp  
auctus.co.jp

### NORWAY

*Ximco*  
+47 33 46 76 53  
mail@ximco.no  
ximco.no

### RUSSIA

*ProSnow*  
+495 739 54 02  
info@prosnow.ru  
prosnow.ru

### SWEDEN

*Ski Dad*  
+46 702 47 76 32  
info@skidad.com  
skidad.com

### UKRAINE

*VIS Distribution*  
+38 44 360 20 79  
info@visdistribution.com  
visdistribution.com

---

## NORTH AMERICAN SALES REPS

### ASHLEY HART

*Sales Manager*  
ashley@icelantickis.com  
401.714.3920

### DUSTIN LITTLETON

*East Coast Rep*  
dustin@icelantickis.com  
607.742.6052

### ERIC RUTISHAUSER

*Rocky Mountain  
& Intermountain Rep*  
eric@icelantickis.com  
720.323.9384

### TIM EBERLY

*Northwest Rep*  
tim@icelantickis.com  
503.914.9629

### JESSE SORESENSEN

*Midwest Rep*  
jesse@icelantickis.com  
605.254.5248

### JOSH MARINO

*Greatlakes Rep*  
josh@icelantickis.com  
314.616.2133

### HARRISON MONTGOMERY

*Southeast Rep*  
orshappy@aol.com  
703.622.2818

### CHRISTIAN PAGE

*Alaska Rep*  
christian@icelantickis.com  
907.440.6069



INSIDE COVER: ALEX TARAN | SNOWBIRD, UT PHOTO STEVEN LLOYD

FRONT COVER: REBECCA SELIG | LA PARVA, CHILE PHOTO ANNELISE LOEVLIE

BACK COVER: BEN ANDERSON | BERTHOUD PASS, CO PHOTO JEFF NASS



**ICELANTIC HQ**

621 Kalamath Street  
Denver, Colorado USA  
80204

303.670.6804 **PHONE**

303.670.6818 **FAX**

1.800.614.5230 **TOLL-FREE**

[info@icelanticskis.com](mailto:info@icelanticskis.com)  
[icelanticskis.com](http://icelanticskis.com)

[facebook.com/icelanticskis](https://facebook.com/icelanticskis)  
[twitter.com/icelantic\\_skis](https://twitter.com/icelantic_skis)  
[instagram.com/icelantic\\_skis](https://instagram.com/icelantic_skis)