

HEAD[®]

HARDGOODS

WINTER
2014/15



THANK YOU LIMITS.
THANK YOU FOR MAKING ME SET GOALS.
FOR GIVING ME SOMETHING TO STRIVE FOR.
WITHOUT YOU LIMITS, THERE WOULD BE NO
CHALLENGE.
NO TEARS.
NO TRIUMPH.
THANKS TO YOU, I GROW AND PROGRESS.
FORGING NEW PATHS BEYOND THE
BOUNDARIES YOU SET.
YOU FORCE ME TO UNDERSTAND WHO I
REALLY AM,
BY TAUNTING ME TO PUSH MYSELF HARDER.
BECAUSE YOU TRY TO HOLD ME BACK,
I CANNOT BE STOPPED.
WHAT'S YOUR LIMIT?

~~WHAT'S
YOUR
LIMIT?~~





HEAD
MASTER
68X 10011

HEAD
STANDARD
73H 10008

HEAD
STANDARD
68L 10016

HEAD
STANDARD
68L 10016

HEAD
MASTER
70X 10021

HEAD
MASTER
70X 10019

3
10



THE MAN WHO LOVED WHAT SKIING COULD BE.

For hundreds of years, ski technology barely changed. Sure, stronger woods made an appearance, camber came onto the scene, and tips and tails got wider, but that was about it. And then one day in 1947, an aeronautical engineer named Howard Head went skiing for the first time. And he was not impressed.

Howard knew there had to be a way to make skis lighter, faster, and more friendly. He set to work for three years, creating one prototype after another, and step by step, the HEAD ski came to life.

With its plywood core, aluminum sheets, plastic sidewalls, and a continuous steel edge, it was a revolution on the slopes. Suddenly anyone could ski and have fun at the same time. And the rest, along with the competition, was history.

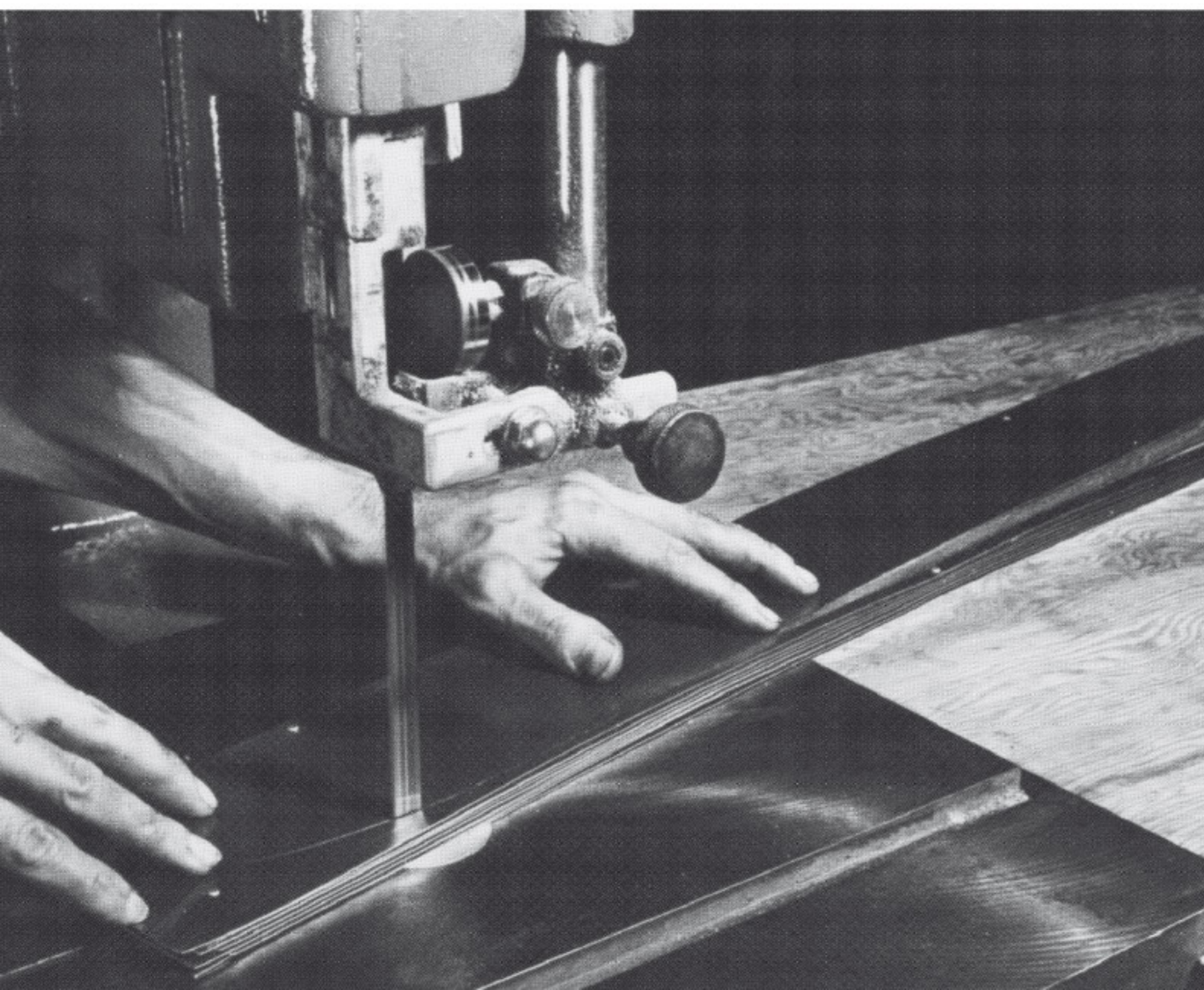

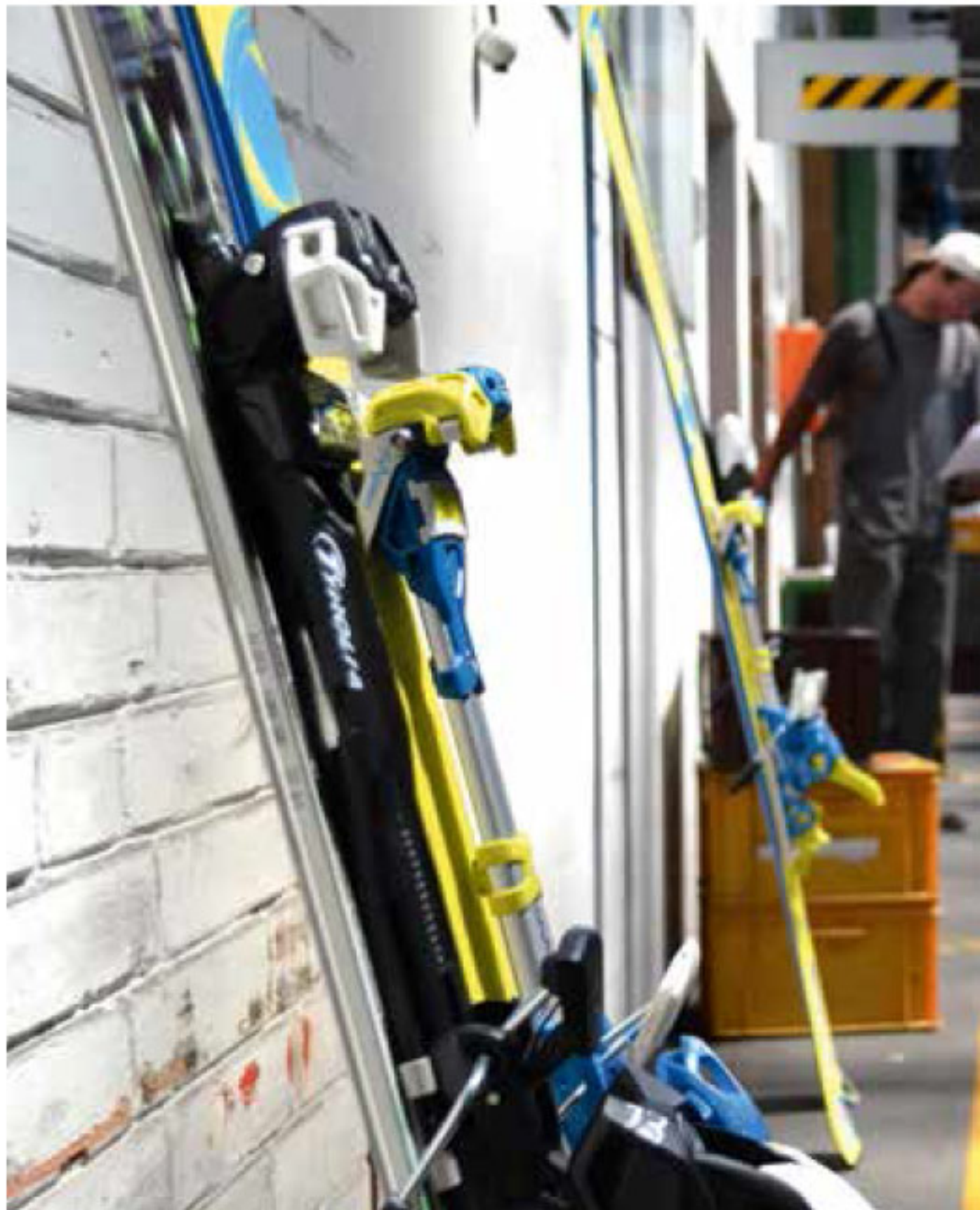
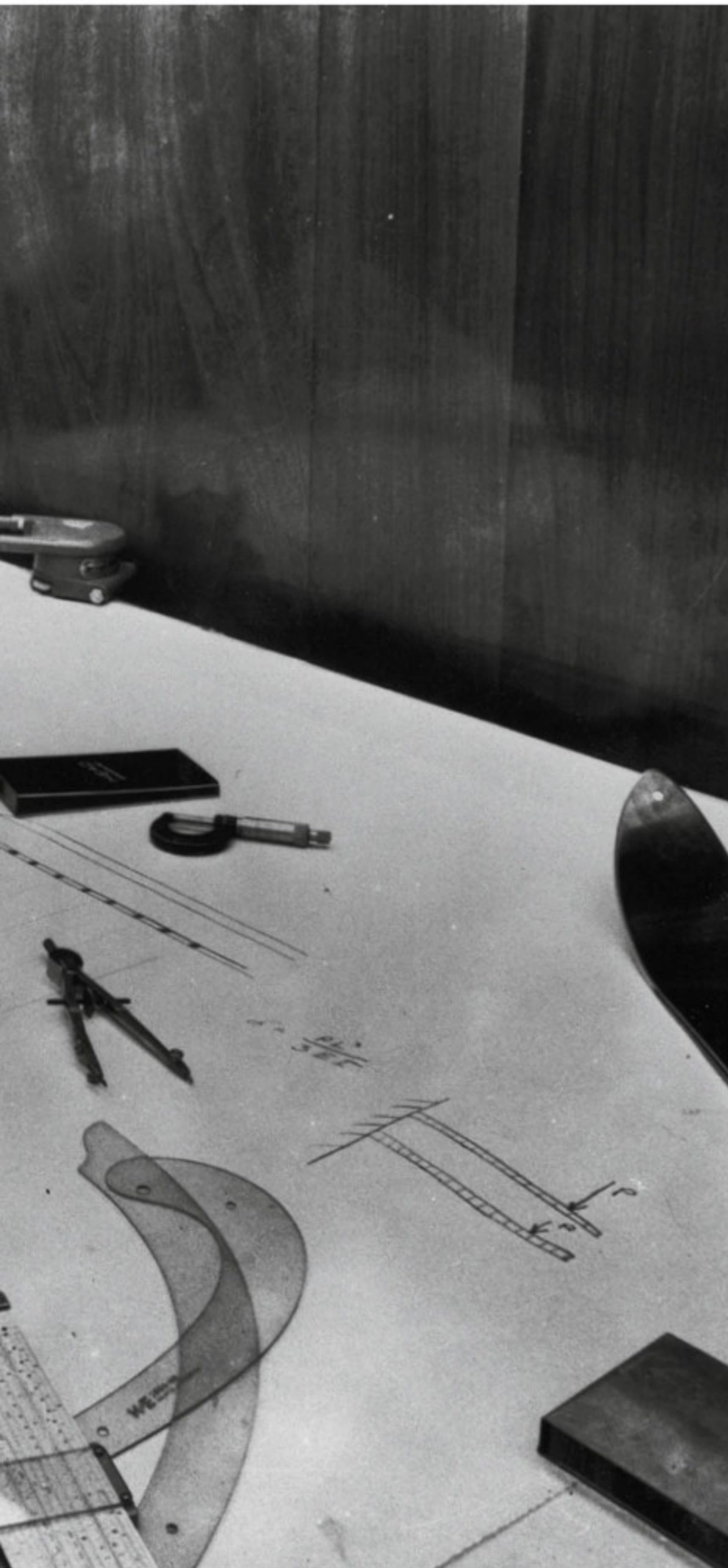



BEHIND THE SCENES:

IT'S EASY TO LOOK AT A SKI OR A BOOT AND FORGET ABOUT THE WORK THAT WENT INTO IT.

That's the problem with brilliant engineering: it only makes itself apparent when the ski disappears beneath you. It's the problem with incredible design: a boot can be so sublimely comfortable that you can totally focus on other things – like the finish line. And it's the burden of every athlete – the faster they go, the easier they make it look.

At HEAD, we're inspired by those who push themselves, drive the sport, and create solutions. And if you ever get to visit our headquarters, you may find that we're inspired pretty much all the time – because we're surrounded by those people every day.

So we'd like to take a moment to say thanks to every staff member and all our athletes. Together, you're pushing the industry forward, and inspiring more and more people to put on skis and discover this beautiful sport. And every time we ask you What's your limit? The answer only opens another question, What limit?.







RACE **COMBO**

**WHEN YOU'VE SEEN THE SPEED OF
LIGHT
WHEN YOU LIVE ON THE EDGE
WHEN ADRENALIN IS YOUR ONLY
FUEL
WHEN YOU ARE THE ONLY
OPPONENT TO BEAT**

WHAT'S YOUR LIMIT?

A hundredth of a second isn't the difference between first and second, it's the difference between winning and nothing at all. If you race, you understand. A centimeter is the grandest of canyons, and there's no such thing as fast enough. But thanks to our athletes and their insatiable demand for more speed, better speed, and faster speed, we're all going a lot quicker. This is trickle-down technology at its finest. Though anything that fast could hardly be called a trickle.

WHEN YOU'VE SEEN THE SPEED OF LIGHT



PERFORMANCE COMBO

**WHEN SLOWING DOWN IS A WASTE
OF TIME
WHEN YOU LIVE LIFE TO THE FULLEST
SPEED
WHEN YOU TURN FEAR INTO
TENACITY
WHEN YOU ARE USED TO USING THE
FAST LANE**

WHAT'S YOUR LIMIT?

Winter can't come fast enough and never lasts long enough. Likewise, no run is fast enough or lasts long enough. But with snow on the ground and the right equipment at your feet (and everywhere else), there is bliss around each turn, and satisfaction at the end of every run. And during those magical, powdery months, there is no limit to how hard we will push ourselves to make the most of every moment. Is it winter yet? How about now?

WHEN SLOWING DOWN IS A WASTE OF TIME



ALLRIDE COMBO

**WHEN YOU ENJOY EVERY
TERRAIN
WHEN THE IDEALS ARE THE ONLY
THING YOU FOLLOW
WHEN YOU LOOK BEYOND THE
HORIZON AND THEN GO TO SKI THERE
WHEN FOCUS CONQUERS FEAR**

WHAT'S YOUR LIMIT?

Specialization is the mother of progress. Every season, specialized freeriders are going bigger and specialized racers are going faster on specialized equipment and specialized terrain. On the other hand, specialization kills freedom. The freedom to decide in the middle of the chair lift ride, whether you're going to race down the front or freeride down the back of the mountain. The freedom to pull out of a multiple-G-turn and veer to the left into a virgin couloir. The freedom to go for one last full speed run on twilight ice as the sun sets behind the peaks you've ridden.

WHEN YOU ENJOY EVERY TERRAIN



FREESKI COMBO

**WHEN YOU GET OUT OF LINE TO FIND
YOUR OWN
WHEN YOU SKI WHAT OTHERS
GOOGLE
WHEN YOU'RE SLAVE ONLY TO
FREEDOM
WHEN TIME STOPS WHILE YOU FLY**

WHAT'S YOUR LIMIT?

There is a mindset that fits into the crowd, follows the path, and stays in the box. And then there's the personality who dies for the challenge and lives for freedom. Those who see skiing as a test of skill, and sometimes of fate. Or as the ultimate form of expression. In man-made, in natural, and sometimes super-natural terrain. Freeriding and freestyle are brothers from different mothers. So is their attitude. And so is our equipment.

WHEN YOU GET OUT OF LINE TO FIND YOUR OWN



WOMEN COMBO

**WHEN EVERY TURN BRINGS
A SMILE OF JOY
WHEN YOU FIND THE PERFECT LINE
WHEN YOUR GEAR FINALLY MEETS
YOUR ASPIRATIONS
WHEN YOU TURN BAD
WEATHER INTO GOOD KARMA**

WHAT'S YOUR LIMIT?

True love for skiing is unconditional. It's not about flawlessness, prettiness, or prowess. It's about expressing yourself, not impressing others. Faith moves mountains, confidence skis them – from daybreak until nightfall. Whatever your line and your limit: The right equipment will turn bad weather into good karma, terrible hair days into big air days, and I-don't want-to-run-days into ounces of pure, striking gold.

WHEN YOU FIND THE PERFECT LINE



JUNIOR COMBO

**WHEN YOU MATCH TALENT WITH
TENACITY
WHEN YOUR STRIDE GROWS WITH
EVERY STEP
WHEN SPEED MEETS SWEET
WHEN YOU TEACH YOUR
PARENTS**

WHAT'S YOUR LIMIT?

The concept of being «in the moment» is something only grown-ups strive for. Because when you're young, there simply is no other state. Here and now is everything that counts. This jump. That turn. This achievement. But also this pain. This cold. This fear. Kids are instant and fierce judges of the quality of their equipment. When it doesn't work, before you know it, the entire family is back in the car and on their way home. Getting it right is paramount. To us. For you. Their parents.

WHEN YOU MATCH TALENT WITH TENACITY



WOMEN'S SKI ARCHITECTURE

At the heart of the Libra, Women's Ski Architecture, is GRAPHENE™. GRAPHENE™ is the first crystal that is two dimensional, giving the material a unique set of properties. It is the thinnest and lightest element ever discovered by mankind. GRAPHENE™ is also the strongest material on the planet, stronger than diamond and 300 times stronger than steel, all in the thickness of one atom. GRAPHENE™ is at the center of the new JOY collection, outstanding lightness with a perfectly balanced ski and always in complete control.

SKIS



Lightness



Balance



Control



Light done right.



Lightness

THANKS TO THE LATEST SUPER LITE AND SUPER STRONG MATERIALS

20% LESS WEIGHT



True to HEAD's DNA, we remain on the forefront of ski technology. And now we are incredibly proud to introduce **GRAPHENE™** – an incomparably light and unbelievably strong material. Layers of **GRAPHENE™**, only a single atom thick, combine to make skis that flex and react intuitively to even the smallest inputs. When mixed with other lightweight materials like **Koroyd™** and carbon, **GRAPHENE™** enables weight savings of up to 350 grams.

Balance

TROUGH UNIQUE WEIGHT DISTRIBUTION PROFILES

With **GRAPHENE™** we are able to manipulate the geometric profile and weight distribution of the ski in any way we like. Depending on the nature of the ski model, the type of skier, and the expected snow conditions, we fine-tune weight and flex distribution characteristics to optimize the skiing experience. Never before has a ski been more perfectly balanced or more efficient – in every model of the size run. In our new women's line, each ski's weight distribution is set up for one of two categories: "on-piste" and "off-piste".



Control

WITH WOMEN'S CAMBER AND ERA 3.0

Thanks to **GRAPHENE™**, our women's camber has a lower profile, which makes for easy turn completion and truly epic performance. And because the handling of the ERA 3.0 Rocker has been enhanced, it's not just the turns that are easier to execute – even changes from edge to edge are effortless. With **GRAPHENE™** you always have grip and control – in every situation, through all conditions, with every move you make.



SKI TECHNOLOGY | FRAMEWALL



FRAMEWALL

The extraordinary stressing of Park&Pipe skis generally result in fast abrasion and easy chipping of the top sheet. This problem has been solved by the all new FRAMEWALL. The three dimensional build of the sidewalls covers the skis top sheet and prevents it from chipping and other external hazards, which results in delamination. The FRAMEWALL is the first 360 protector on a ski, that increases the skis durability and performance considerably!

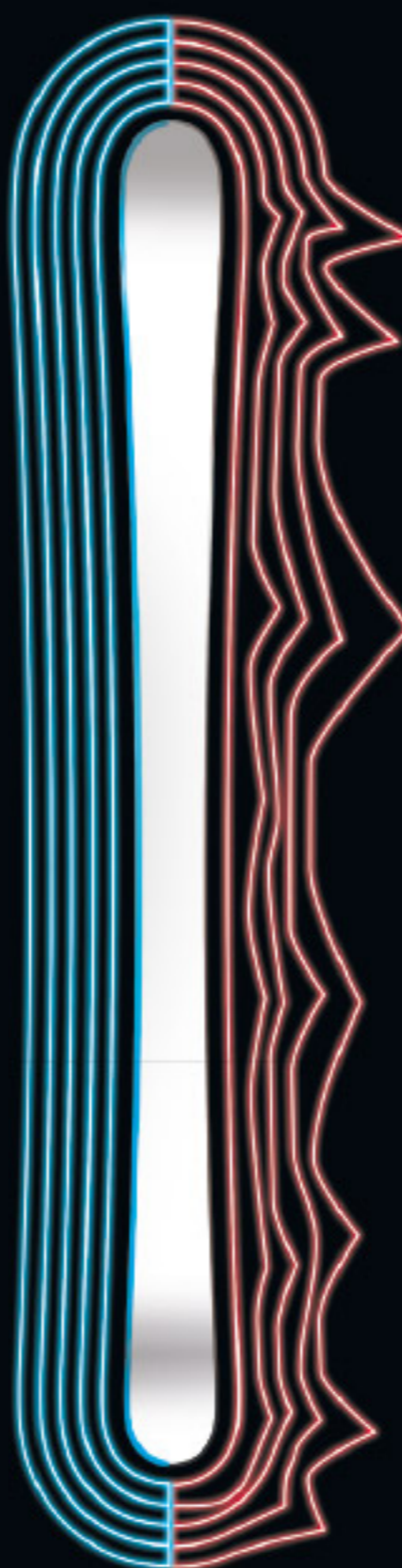

TRIFLEX TECHNOLOGY

HEAD TRI Flex base

For the first time a FreeFlex System, is integrated in a newly designed base system, the HEAD TriFlex base. For unhindered natural ski flex, the base is secured by one fixed pair of screws and three special gliding devices. This offers multiple flexing opportu-

nities to the front, to the rear and on the base, allowing the ski to retain its natural flexibility and dynamics. The Dynamic Rebound System – DRS with its two power-springs, enforces the inherent ski rebound and allows faster edge-to-edge transition, with more powerful and agile skiing at the highest level.

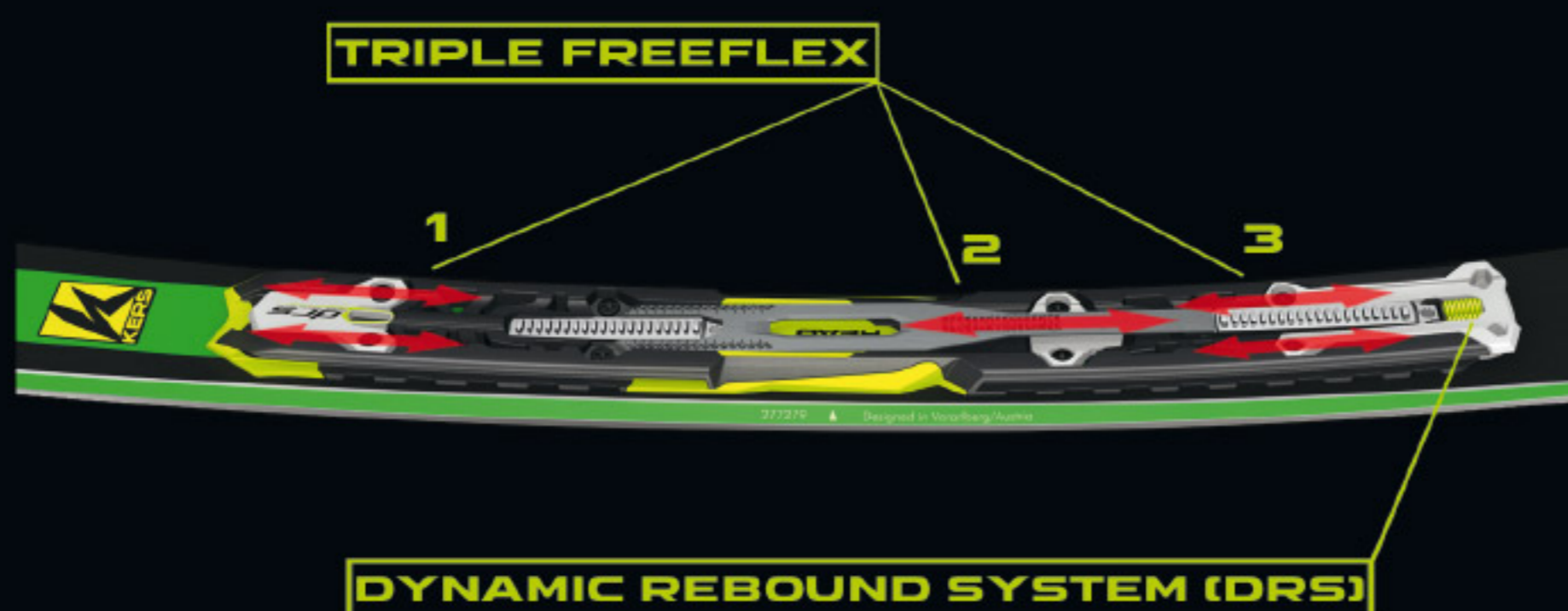

SUPERLITERAIL – SLR BASE

The new SuperLiteRail base has a wide contact interface on the ski – 30 % wider than the LiteRail. In combination with the integrated Freeflex-Function the SLR base guarantees constant force distribution which leads to flawless control and performance, without affecting the natural ski flex.

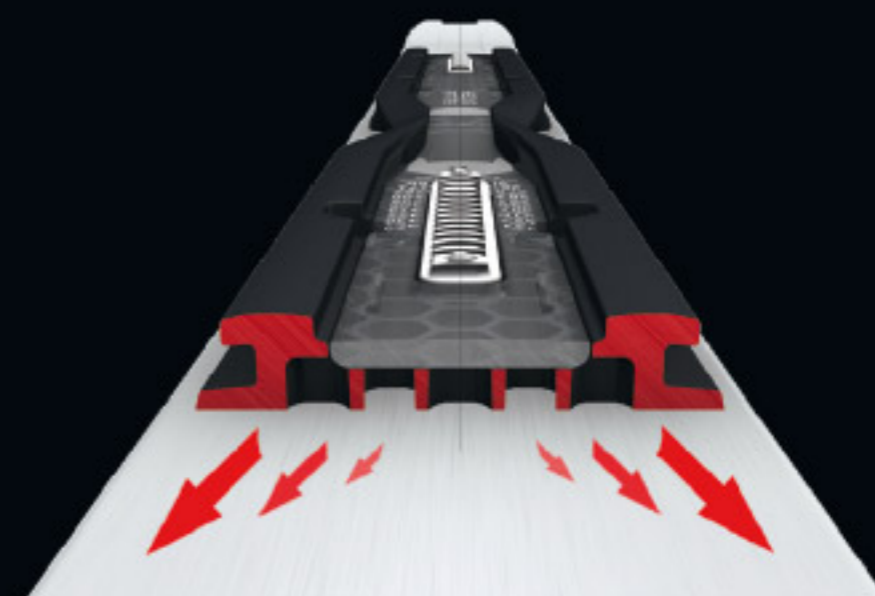

SKI TECHNOLOGY I KERS



THE EXTRA BOOST

KERS Technology works like a turbo charger that provides additional power and acceleration by stiffening the tail of the ski in outturns.

The effect: a boost, catapulting the rider into the next turn. Just like when Formula 1 pilots push a button for that extra notch of Speed. HEAD KERS Technology is an electronic, fully automatic and integrated system.

TECHNICAL BACKGROUND

HEAD KERS Technology is an evolution of the idea behind HEAD's Intelligence™ Technology. But unlike Intelligence™, KERS does not influence the torsional stiffness of the ski, KERS empowers the skis' longitudinal flex. Also KERS Technology is based on a completely new chip capable of accumulating power and keeping it in store for the right moment. Piezoelectric fibers transform kinetic energy into electrical energy which is stored in the embedded chip in the ski. Electrical energy is immediately released to areas of the ski, where additional energy is requested by the sensor. Timing and release are automatically controlled and coordinated. Depending on the flex pattern of different ski models, sensors are programmed beforehand: the more aggressive the ski has to be, the stiffer the tail will become.

Skis experience maximum flex at the end of a turn. At this moment an active microchip releases energy into the fibers of the tail. The tail of the ski then stiffens up, immediately increasing rebound for maximum acceleration at the end of the outturn.

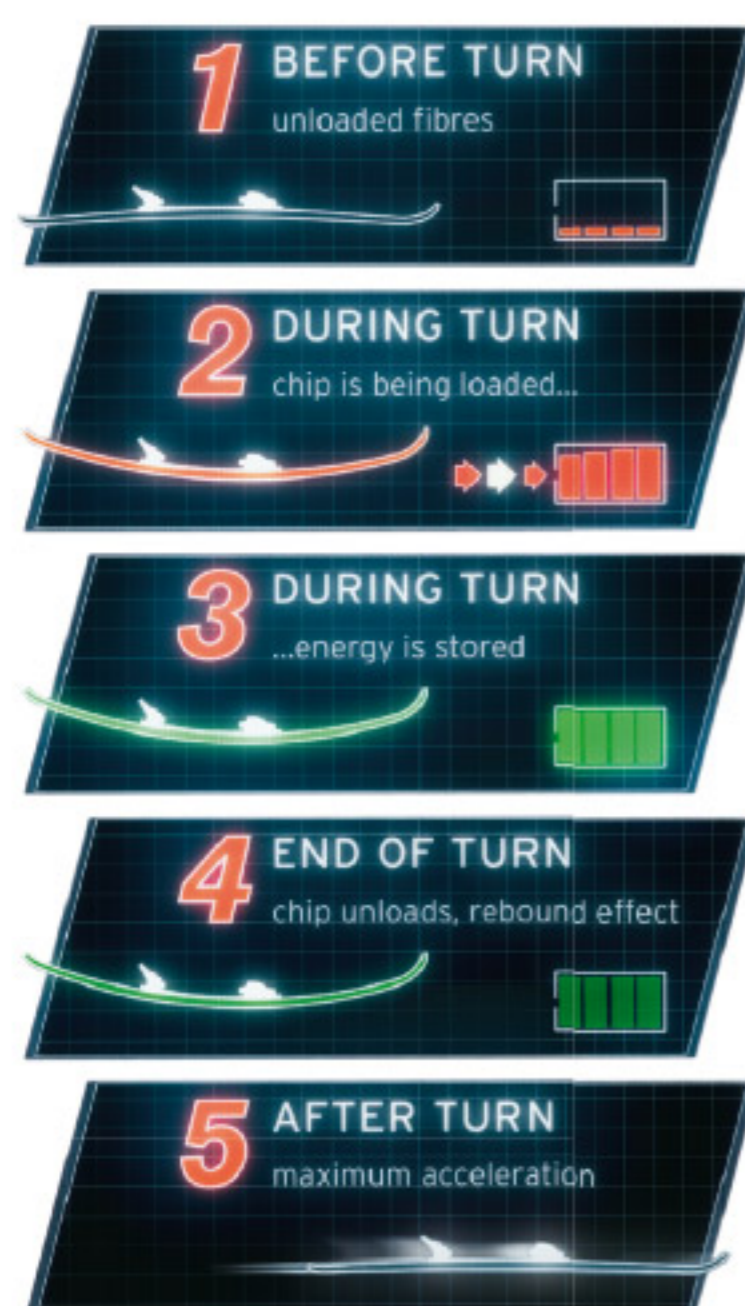

ELECTRONIC SKI MANAGEMENT SYSTEM

HEAD's theory of relativity: Ski performance is not an absolute measure. What you want out of a ski always depends on how and where you ride. On hard-packed slopes you want perfect edge grip. On soft snow, you want more maneuverability. Breaking the slope record you want your ski to perform differently than when you're just cruising with your friends or family. Adaptive HEAD Intelligence™ Technology helps your ski perform perfectly – both relative to terrain and your individual riding mode.

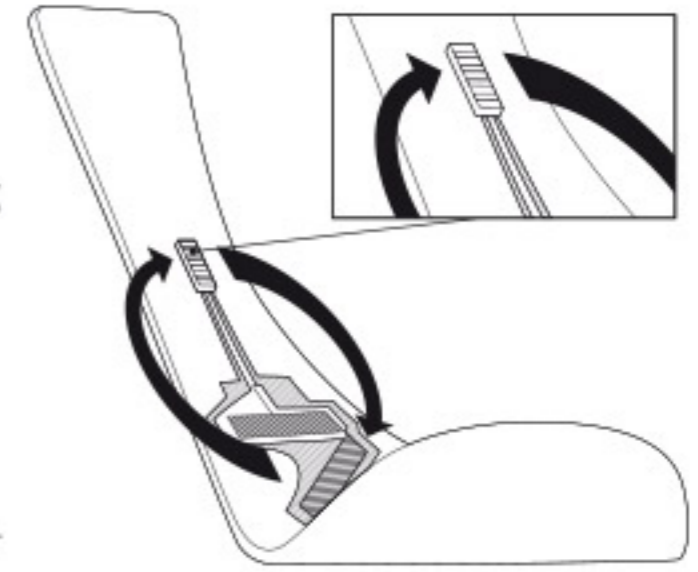

HOW IT WORKS

Intellifibers positioned at 45° in front of the binding transform mechanical impulses into electrical energy. The harder you ride, the more energy is produced. The electrical energy is led back to the Intellifibers. This causes them to stiffen up, putting more rebound and torsional stiffness into the ski.

WHAT IT DOES

Their 45° position in front of the binding increases the ski's torsional stiffness, pushing the edge into the snow in hard turns. Intelligence™ progressively stabilizes the entire ski at high speeds.

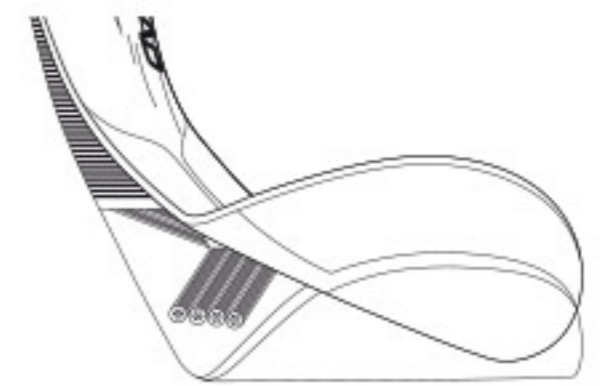

THE EXTRA BOOST

Some HEAD high-end skis boast Intelligence™ Chip Technology. Here, the electrical energy produced by the Intellifibers is not just recycled, but accumulated and released bit by bit through a pre-programmed chip – individually timed to match the oscillation properties of the ski. Thus, the effect of Intelligence™ is multiplied, providing even more performance relative to your skiing style.

BIG MOUNTAIN SKIS WITH BEYOND RACE TECHNOLOGY



TTS – TIP AND TAIL STABILIZER SYSTEM. A SKI WITH REDUCED VIBRATION AND INCREASED DAMPENING AND A SYSTEM TO INCREASE TORSIONAL STRENGTH ALL WHILE AT THE SAME TIME REDUCING SWING WEIGHT.

TTS is a stabilizing exoskeleton which dampens the vibrations normally felt from rockered tips and tails also reduces overall swing weight and creates a ski with a playful yet high level of performance. The system is comprised of an elastomeric inlay for vibration control as well as a glass fibre exoskeleton for stability and torsional strength. This combination not only reduces vibrations but creates better pressure distribution upon entry and exit of a turn by minimizing lateral flex of the ski. Reducing overall vibration means better edge control and therefore increasing overall skiing performance and skier experience. In addition, the reduction of necessary core materials in the tips and tails has created a lighter swing weight for easier handling and maneuverability both on snow and in the air.

Rocker done right.

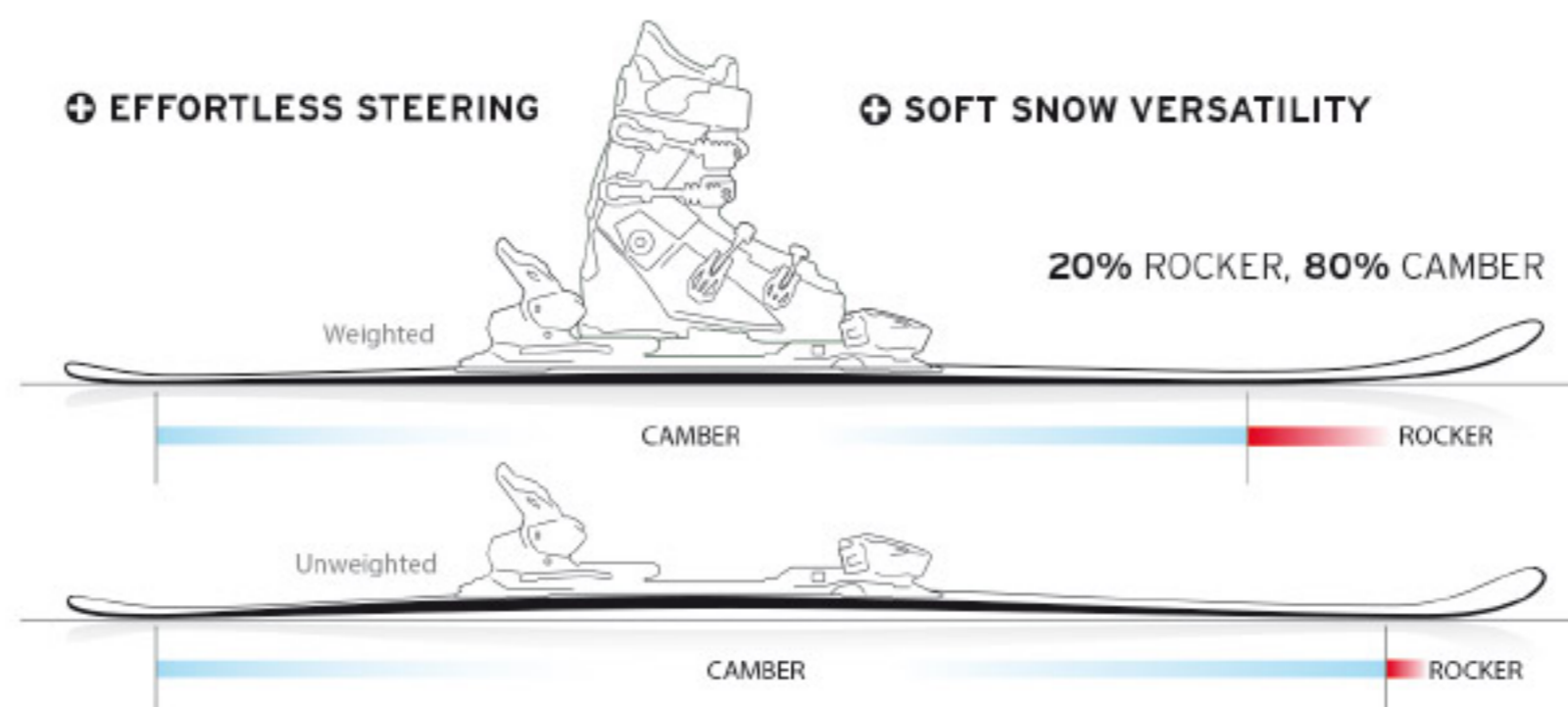

01

ALLRIDE ROCKER

A rocker who feels comfortable on the steepest slopes and deepest pow - made for skiers who feel comfortable on steepest slopes and deepest pow, and who are always ready to make the best out of every single skiing day. Allride Rocker enables superior steering and increased floatation. We place exactly the right amount of rocker in each model to ensure maximum performance for all ability levels. Steering is easier for all skiers and soft snow versatility is enhanced.



02

PNP ROCKER

Some people want to fly high - If you're one of them, be sure your ski features the PNP Rocker. Consider it a pair of wings for skis, developed in the HEAD freestyle laboratory. Our Park & Pipe Rocker incorporates tip and tail rise with regular camber underfoot. PNP gives skis a significant amount of pop and energy for boosting tricks. So dive in, go bigger, fly further, and rock the park and pipe as hard as you can.



03

SPEED ROCKER

For perfect handling on hardpack - a slight tip rise on a ski with standard camber, which means great performance, easy turn initiation, and high versatility on soft snow. 10% rocker and 90% camber is just enough to take the sting out of the edges, while keeping the bite you need to turn. Speed Rocker turns HEAD performance skis into a weapon of speed with power steering. It's fast. Are you?



04

TNT ROCKER

For more powerful freeriding - Tip & Tail Rise meet partial camber: The recipe for great float and freedom in powder with enough standing power to enjoy those days you didn't pray for snow. Really the best of both worlds. 40% Rocker is radical enough to satisfy the freeridin' soul. 60% Camber helps keep your speed and your budget in check - because with the versatility of TNT rocker, you'll have to buy one less ski for your quiver.



05

JUNIOR ROCKER

For perfect allride performance. Kids don't like compromises. But they don't like sticking to decisions either. One day they're a rockstar. And the next day they want to be a bunny. With 20% rocker and 80% camber, kids get tons of float, easy turn initiation, and plenty of speed and control. HEAD's Junior Rocker simply works for anyone, anywhere.



SKIS TECHNOLOGY ERA 3.0

era3.0
EVOLUTIONARY
ROCKER ARCHITECTURE

ERA 3.0

Imagine a ski that performs for everyone, anywhere: One for all. All in one. HEAD ERA 3.0 is not your one-dimensional «Have a problem? We fix it!» technology. ERA 3.0 is a combination of technologies, shape and geometry. Think Rocker, think Radius, think Rebound. Think 3-dimensional.

ALLRIDE ROCKER

For superior steering and increased floatation. We place a highly targeted amount of rocker in each model to ensure maximum performance for all ability levels. Steering is easier for all skiers and soft snow versatility is enhanced.

PROGRESSIVE RADIUS

For tremendous turning. Regular rocker makes skiers place their ski further on edge to have it touch from tip-to-tail. With progressive radius, up to 50% less angulation is needed to enjoy full edge contact. More edge on the snow = more edge grip.

INTELLIRISE REBOUND

For targeted stability. We move our legendary piezoelectric Intellifibers to the tip of the ski. The nasty tip vibrations found on regular rockers are not found here. These skis are too smart for that.

ERA 3.0 S

The Supershape line was called the Supershape because from its inception it was shaped to perfection. Now, the Supershape has taken on ERA 3.0 S.

It's the sports version with a multifaceted ski designed with race innovation and inspiration, yet now with

the addition of Rocker, Radius and Rebound. With a totally unique V-Shape construction this is not just a new ski, it is a totally new skiing experience. The new Supershape with ERA 3.0 S is the combination of all mountain carving, race technology,

and a new gradient on turning mechanics and ski capabilities sure to impress skiers on many levels. 10% Rocker and 90% camber are combined to impress. The additional layer of Intellifibers provides explosive power, control and increased responsiveness.

ERA 2.0

THE LITTLE BROTHER OF ERA 3.0. It is everything ERA 3.0 has to offer as far as design, performance and geometry integration,

but without the addition of "Rebound" with its piezoelectric Intellifibers. While we do want to see kids experience skiing performance at the

highest level, they should have the best possible tools to learn and perform.

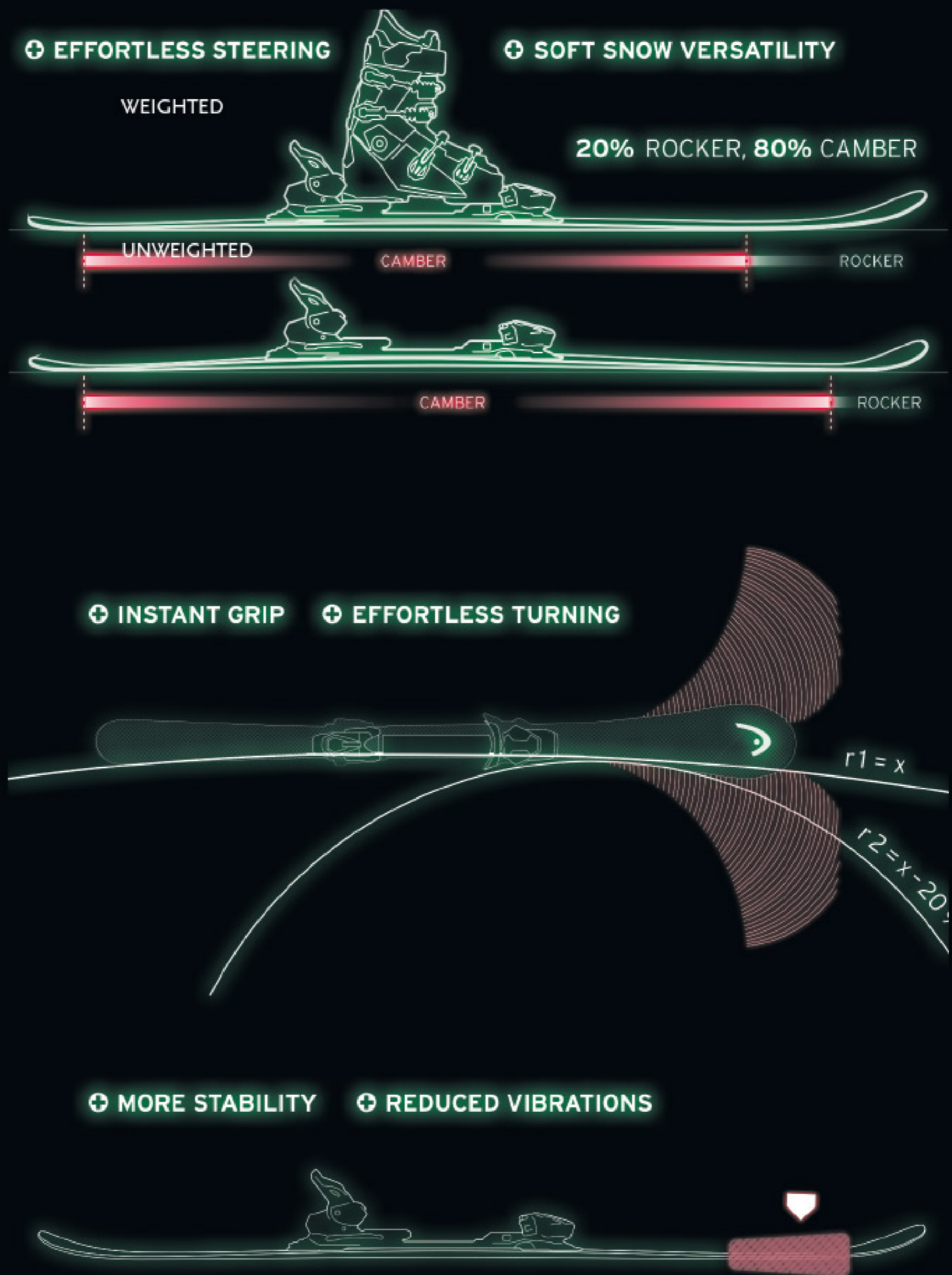

era 2.0

SKIS TECHNOLOGY | HEAD CORE

WORLD CUP SANDWICH CONSTRUCTION

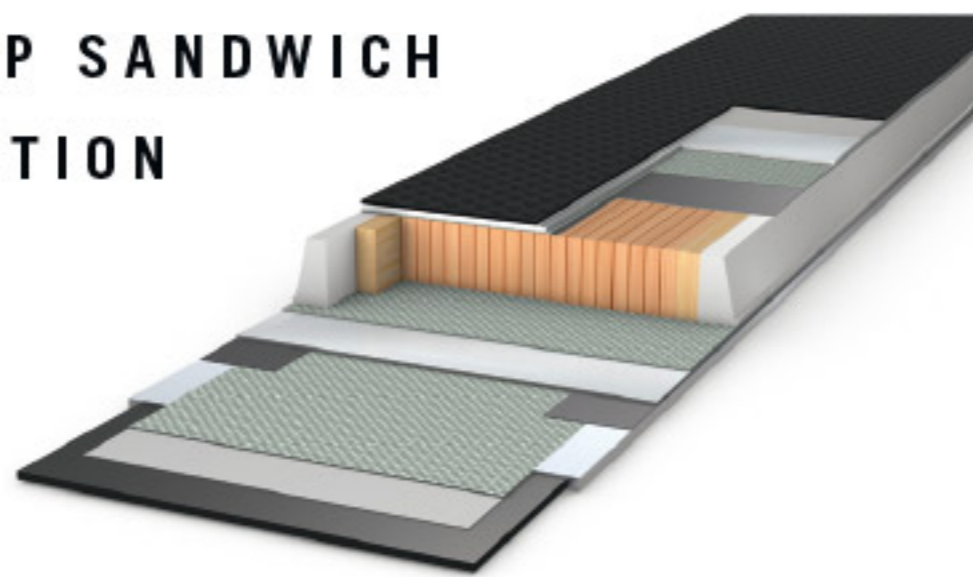

Hand built by the finest ski technicians in the modern world. The vertical laminate wood core is embraced by speedfreak phenolic sidewalls and the finest Titanal. This is the fastest construction on the planet.

WC SANDWICH CAP CONSTRUCTION

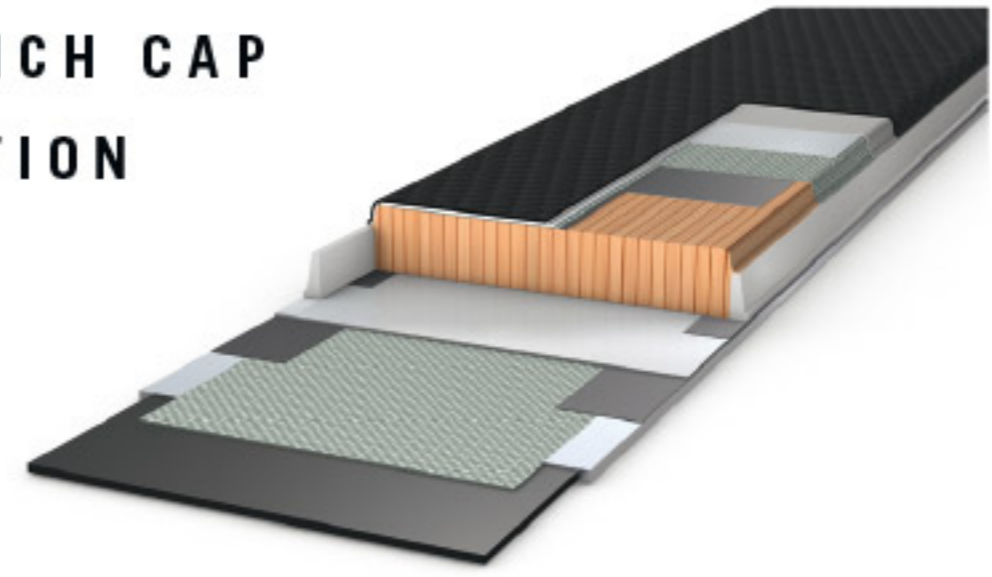

A wood core sandwich construction with Titanal which combines the solid and responsive performance of the vertically laminated wood core and control offered by the Titanal. Upper layer wrapped by Cap that insures longer durability.

WOOD CORE CAP CONSTRUCTION

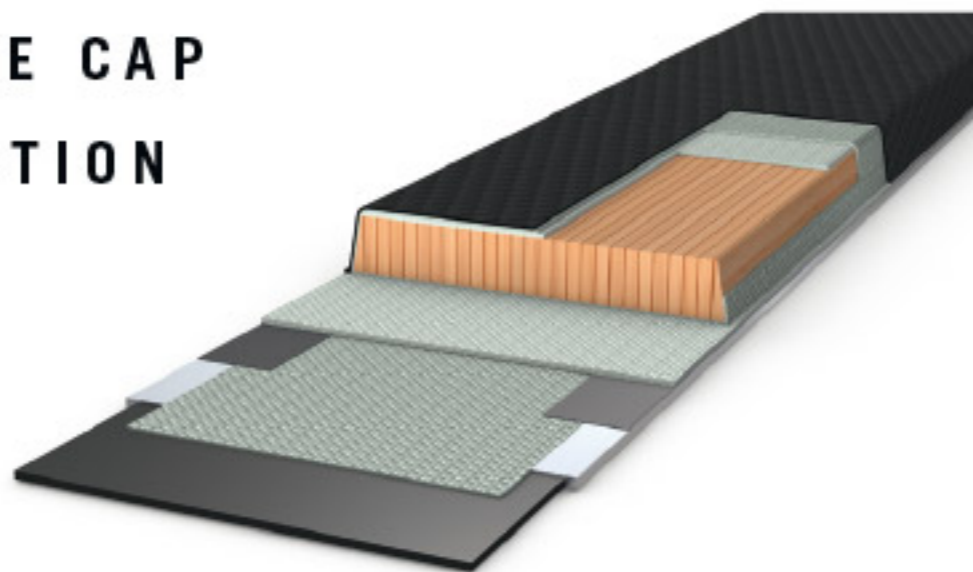

A vertically laminated wood core surrounded by a sock of fiberglass and the whole body is wrapped by a durable topsheet. This forgiving construction is ideal for ramping up the learning curve.

SANDWICH CAP CONSTRUCTION

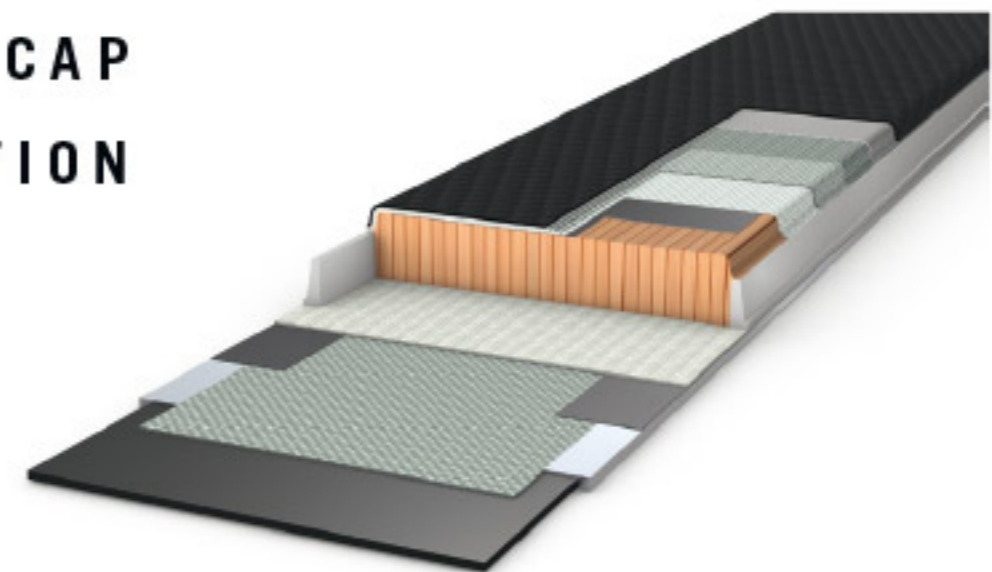

Is the world cup sandwich construction with a cap that wraps over the top edge of the sidewall to make the ski more suitable for all mountain skiing.

WOOD COMPOSITE CORE

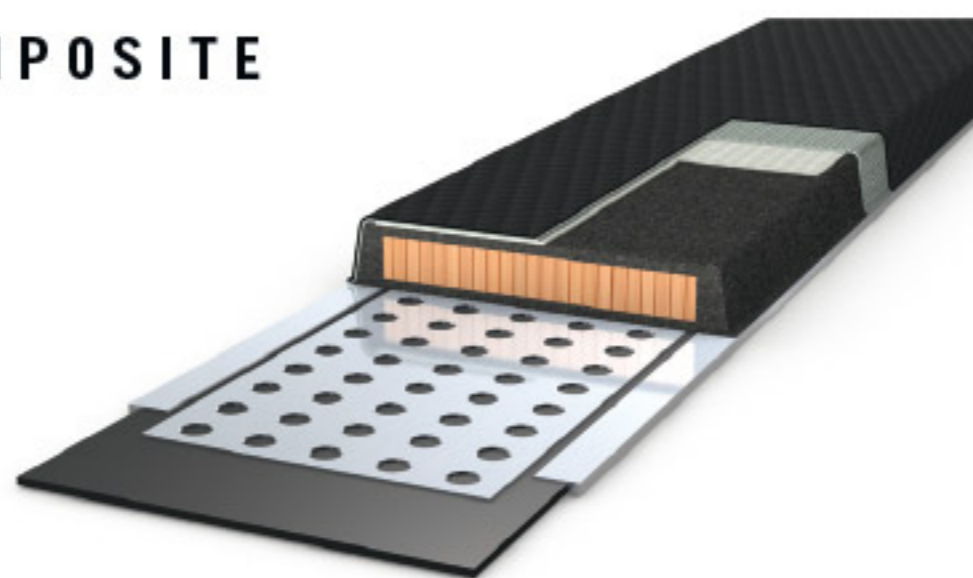

A vertically laminated wood core with a PU injected sock around it. The Cap constructions insures complete protection from mechanical damage. The wood insures stability against vibrations and a smooth ride for target groups looking for entry performance.

POWER SIDEWALL JACKET

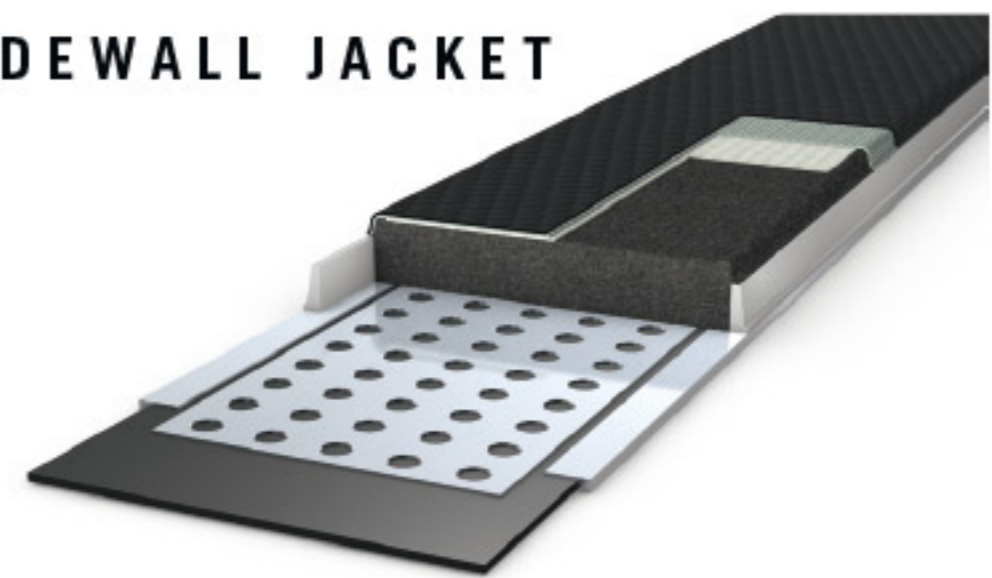

A synthetic injected core supported with ABS sidewalls. This lightweight construction allows for a soft longitudinal flex coupled with a super responsive torsional flex, thanks to the sidewall jacket.

POWER CARBON JACKET

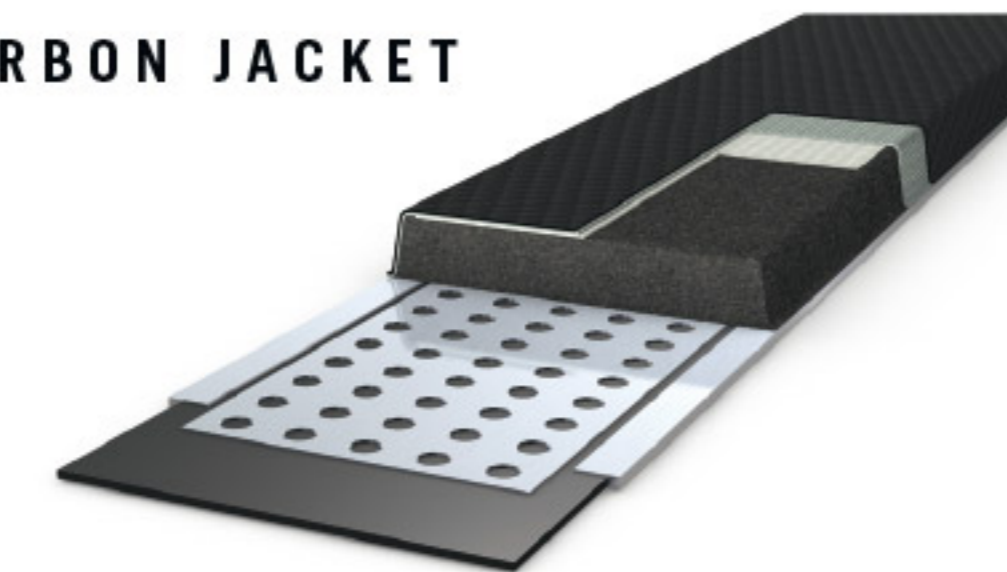

A synthetic core center wrapped by Carbon fibers. Delivers a performance ski that can be used by entry level skiers.

SKIS TECHNOLOGY | WOMAN SPECIFIC CORES

GKC SUPERLITE SANDWICH CAP CONSTRUCTION

Developed with the most sophisticated material known to man, the Superlite sandwich construction uses GRAPHENE, KOROYD and CARBON to guarantee the lightest ski in the world without compromising on performance. The ultimate construction for a high performing women ski.

- | | | |
|-----------------------------|---------------------------------|--------------------|
| 1 Top Sheet | 2 Reinforced glass fiber | 3 GRAPHENE™ |
| 4 Carbon glass fiber | 5 Koroyd | 6 Wood core |
| 7 Sidewall | 8 Dampening Layer | 9 Edge |
| 10 Carbon | 11 Base | |

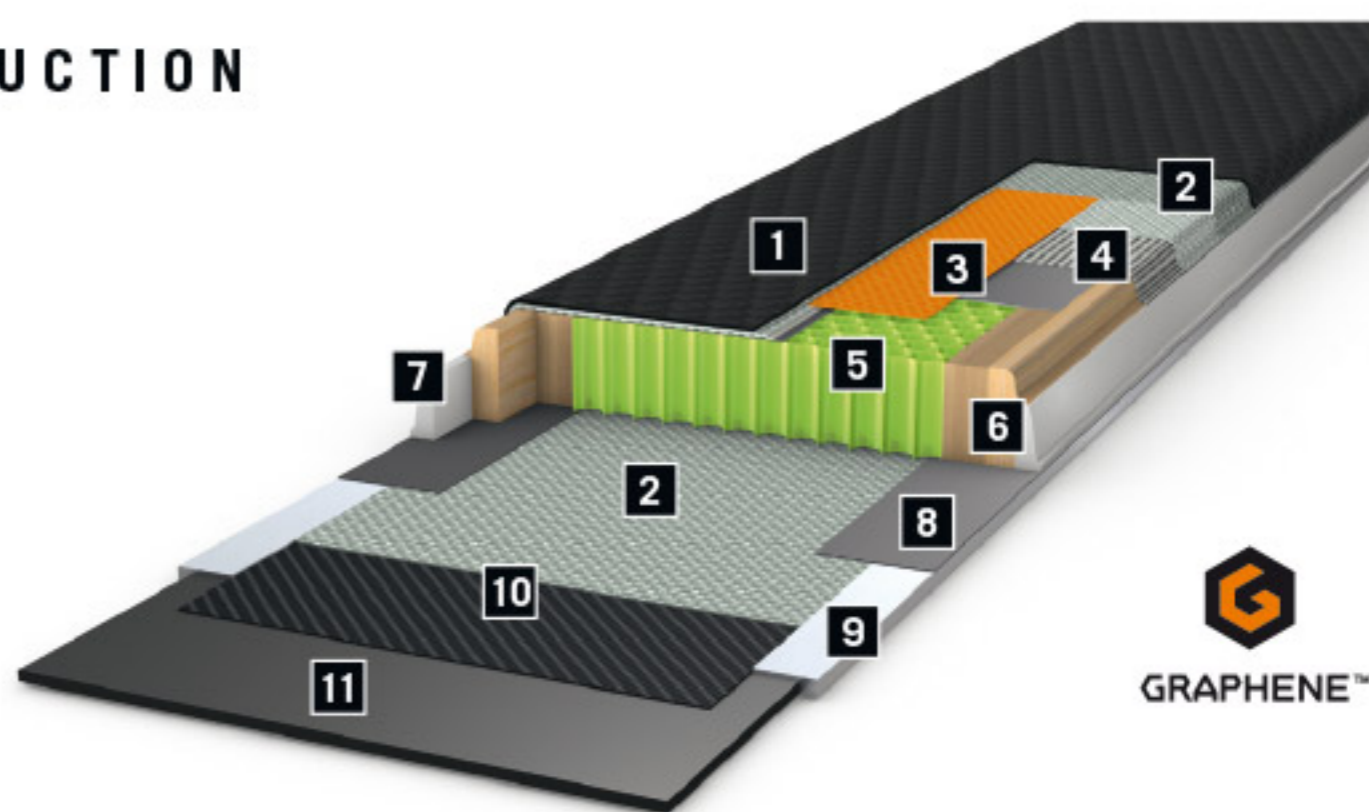

SUPERLITE SANDWICH CAP CONSTRUCTION

Thanks to the unique properties of GRAPHENE, the Superlite sandwich cap construction has had a reduction in the materials inserted with an increase in its responsiveness, allowing faster and more precise change from edge to edge. The ultimate ski for flotation and responsiveness.

- | | | |
|--------------------|-------------------------------|---------------------------------|
| 1 Top Sheet | 2 Glass fiber fleece | 3 Glass fiber |
| 4 GRAPHENE™ | 5 Dampening Layer | 6 Wood core |
| 7 Sidewall | 8 Diagonal glass fiber | 9 Reinforced glass fiber |
| 10 Edge | 11 Base | |

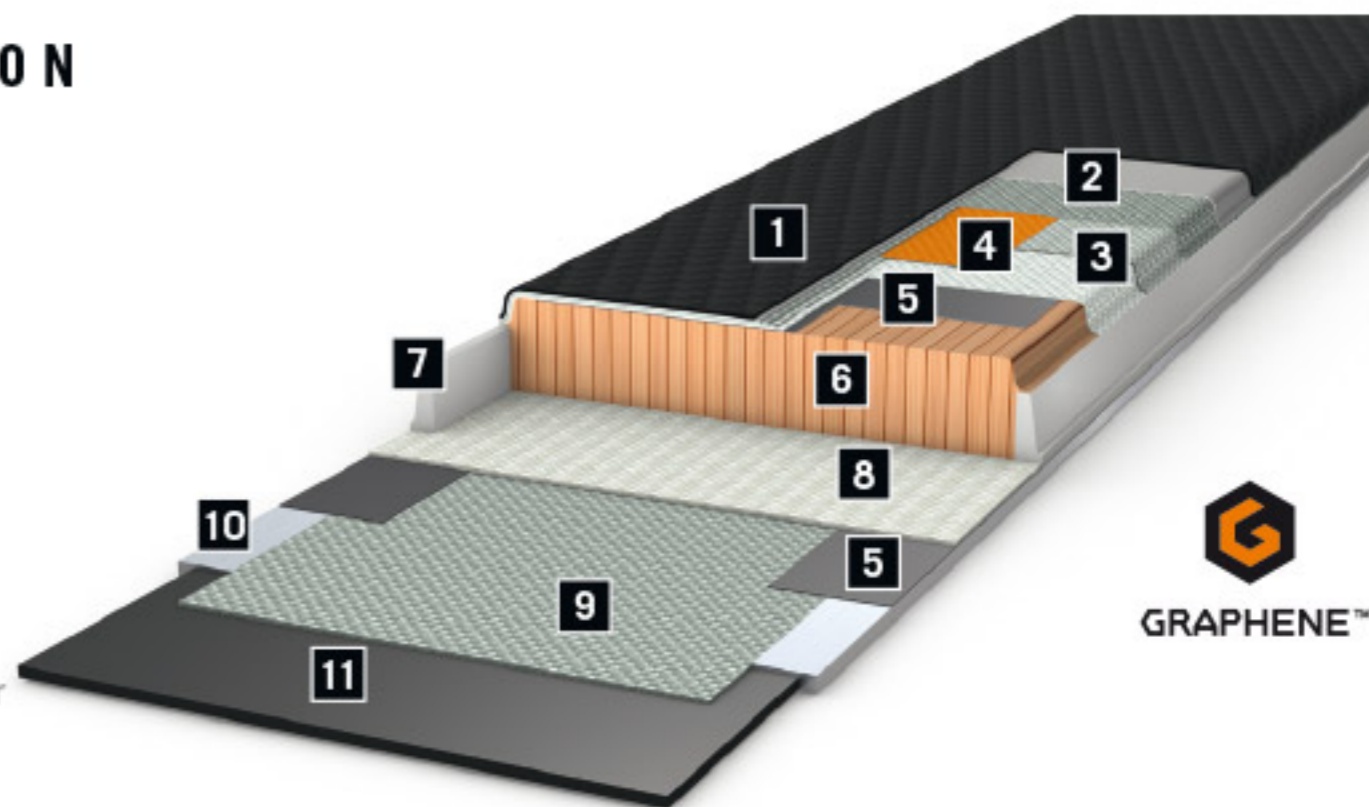

SUPERLITE POWER SIDEWALL JACKET COMPOSITE CORE

To make this construction even lighter, material from the heart has been replaced by a lighter material and a layer of GRAPHENE has been inserted to not only insure the performance is unchanged but actually increased, as the overall thickness of the core is reduced, making it a composite that is easy and forgiving, but always precise.

- | | | |
|-------------------------------|-------------------------|---------------------------------|
| 1 Top Sheet | 2 Glass fiber | 3 GRAPHENE™ |
| 4 Diagonal glass fiber | 5 Synthetic core | 6 Lite core |
| 7 Sidewall | 8 Edge | 9 Reinforced glass fiber |
| 10 Base | | |

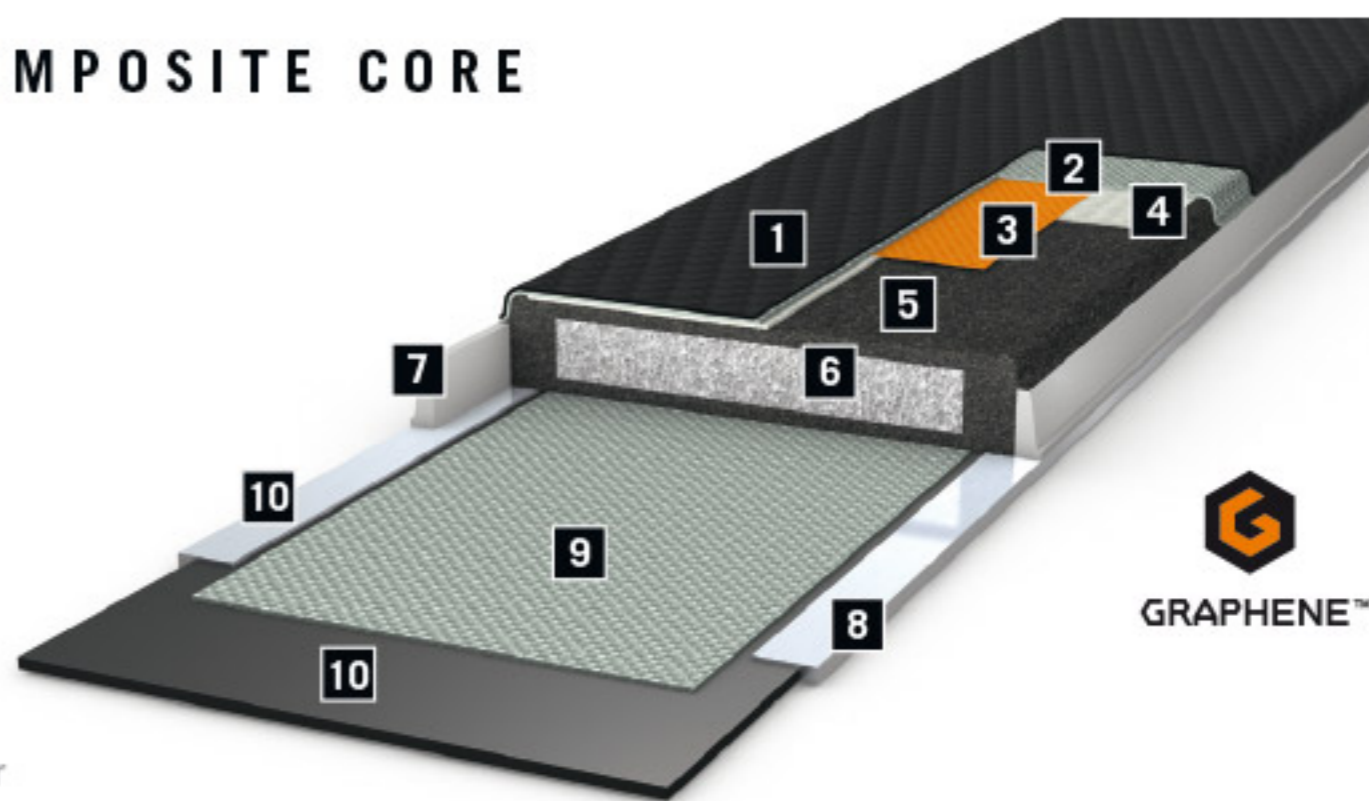

SUPERLITE POWER SIDEWALL JACKET

A synthetic injected core supported with ABS sidewalls. This superlite construction thanks to Graphene allows for a soft longitudinal flex coupled with a super responsive torsional flex, thanks to the sidewall Jacket.

- | | | |
|-------------------------------|---------------------------------|--------------------|
| 1 Top Sheet | 2 Glass fiber | 3 GRAPHENE™ |
| 4 Diagonal glass fiber | 5 Synthetic core | 6 Sidewall |
| 7 Edge | 8 Perforated steel layer | 9 Base |

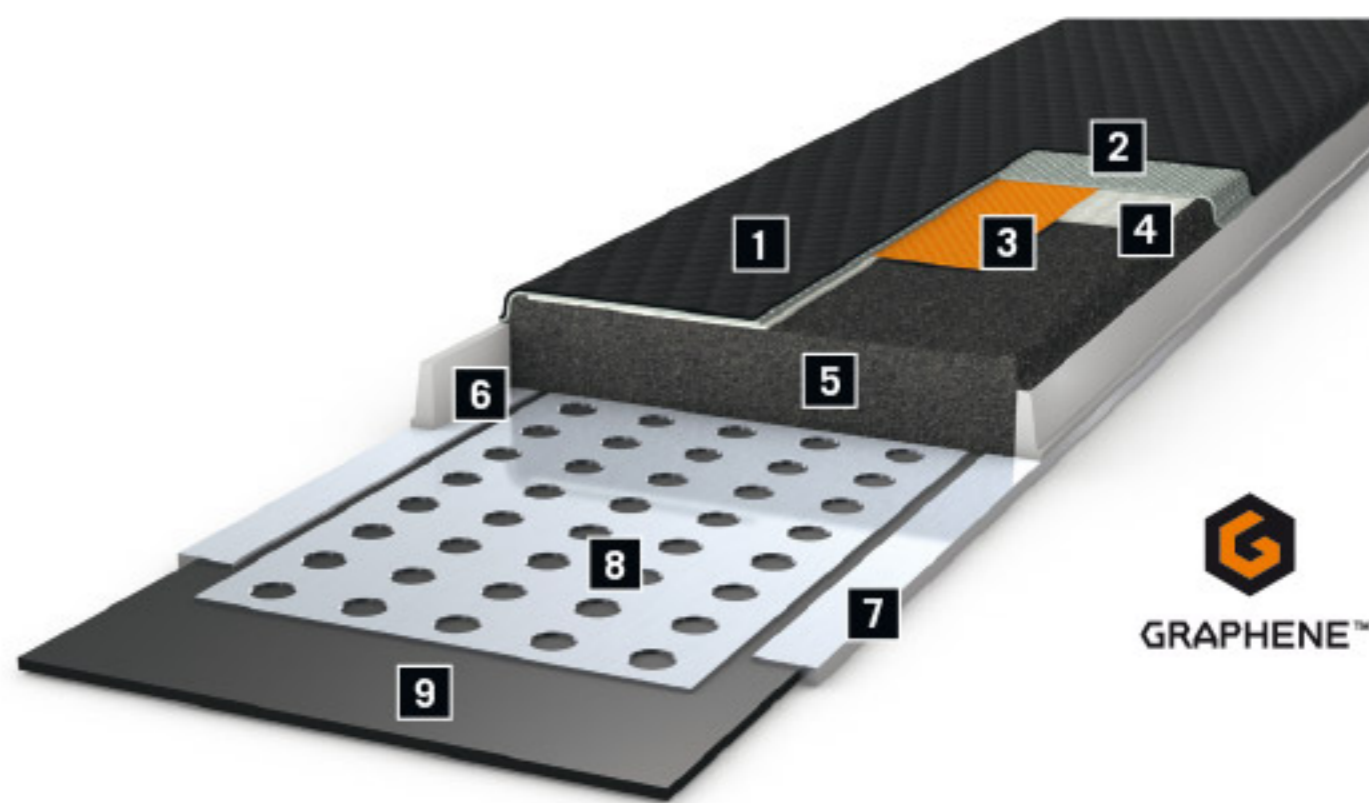

WORLD CUP REBELS i.GS RD M / W

NO SPEED CAN STOP THIS SKI FROM TURNING. WORLD CUP PROVEN.



ART.N°: 310094 (LENGTH 190/195)
ART.N°: 310104 (LENGTH 183/188)

FEATURES

KERS • Intelligence Technology • WC sandwich construction • RD racing top sheet • Race structured high speed • UHM C base • Rebel Camber • FIS approved for World Cup and European Cup only • Infra-Red base Waxing

LENGTHS

190/195
183/188

DIMENSIONS

98/65/81 @ length 195
101/65/82 @ length 188

RADIUS

35,0 @ length 195
30,0 @ length 188

PLATES

HEAD Race Plate RDX

BINDINGS

ART.N°: 100500 FREEFLEX PRO 20 X RD

WORLD CUP REBELS i.GS RD

THE PERFECT TOOL FOR GIANT SLALOM MISSIONS. WORLD CUP PROVEN.



ART.N°: 310054

FEATURES

KERS • Intelligence Technology • WC Sandwich Construction • RD racing top sheet • Race structured high speed • UHM C base • Rebel Camber • FIS approved for Continental Cup and Masters • Infra-Red base Waxing

LENGTHS

176/181/186

DIMENSIONS

102/65/86 @ length 181

RADIUS

25,0 @ length 181

PLATES

HEAD Race Plate RDX

BINDINGS

ART.N°: 100500 FREEFLEX PRO 20 X RD

WORLD CUP REBELS i.DH RD

THE FASTEST SKI ON EARTH, A LOT OF COURAGE NEEDED.



ART.N°: 319904 (LENGTH 218)
ART.N°: 319914 (LENGTH 210)

FEATURES

KERS • Intelligence Technology • WC sandwich construction • RD racing top sheet • Race structured high speed UHM C base • Rebel Camber • FIS approved for World Cup and European Cup only • Infra-Red base Waxing

LENGTHS

218 / 210

DIMENSIONS

92 / 65 / 80 @ length 218
91 / 65 / 78 @ length 210

RADIUS

50,0 @ length 218

PLATES

DH Race Plate

BINDINGS

ART.N°: 100501 FREEFLEX PRO 20 X RS

WORLD CUP REBELS i.SG RD

THE PERFECT SKI FOR ALL SUPER-G GYRATORS.



ART.N°: 319924 (45,0 @ LENGTH 213)
ART.N°: 319934 (42,0 @ LENGTH 207)
ART.N°: 319944 (45,5 @ LENGTH 207)
ART.N°: 319954 (40,5 @ LENGTH 202)

FEATURES

KERS • Intelligence Technology • WC sandwich construction • RD racing top sheet • Race structured high speed UHM C base • Rebel Camber • FIS approved • Infra-Red base Waxing

LENGTHS

213 / 207 / 202

DIMENSIONS

95 / 65 / 79 @ length 213
95 / 65 / 80 @ length 207
93,5 / 65 / 78 @ length 207
95 / 65 / 79 @ length 202

RADIUS

45,0 @ length 213
42,0 @ length 207
45,5 @ length 207
40,5 @ length 202

PLATES

DH Race Plate

BINDINGS

ART.N°: 100501 FREEFLEX PRO 20 X RS

WORLD CUP REBELS i.SL RD

VMAX RIGHT FROM THE START: THIS SIZZLING SLALOM
SKI WAS BUILT TO BURN RUBBER ON SNOW.



ART.N°: 310034

FEATURES

- KERS
- Intelligence Technology
- WC sandwich construction
 - RD racing top sheet
- Race structured high speed UHM C base
 - Rebel Camber
 - FIS approved
 - Infra-Red base Waxing

LENGTHS

156 / 160 / 165

DIMENSIONS

119 / 66 / 98 @ length 156

120 / 66 / 99 @ length 160

121 / 66 / 99 @ length 165

RADIUS

12,8 @ length 156

12,8 @ length 160

13,1 @ length 165

PLATES

HEAD Race Plate RDX

BINDINGS

ART.N°: 100502 FREEFLEX PRO 18 X

WORLD CUP REBELS i.SL

EDGE TO EDGE AND SHORT TURNS HAVE NEVER BEEN SO MUCH FUN.



ART.N°: 310044

FEATURES

KERS • Intelligence Technology • Race structured UHM C base
• WC sandwich construction • Rebel Camber

LENGTHS

150/155/160/
165/170

DIMENSIONS

122/66/107
@ length 165

RADIUS

11,5 @ length 165

PLATES

Speedflex Plate 13

BINDINGS

ART.N°: 100508 FREEFLEX PRO 14

WORLD CUP REBELS i.SPEED

THE FASTEST SKI ON EARTH, A LOT OF COURAGE NEEDED.



ART.N°: 310064

FEATURES

KERS • Intelligence Technology • Race structure UHM C base
• WC sandwich construction • Rebel Camber

LENGTHS

165/170/175
180/185

DIMENSIONS

112/66/94
@ length 180

RADIUS

18,0 @ length 180

PLATES

Speedflex Plate 13

BINDINGS

ART.N°: 100506 FREEFLEX PRO 16

i.SUPERSHAPE TITAN

THIS LEGENDARY SKI FEELS AT HOME ESPECIALLY JUST OFF THE GROOMED PISTE.



ART.N°: 310084

FEATURES

KERS • ERA 3.0 S • Race structured UHM C base • WC sandwich cap construction
• Speed Rocker

LENGTHS

156/163/
170/177

DIMENSIONS

133/80/111
@ length 170

RADIUS

14,3 @ length 170

PLATES

TriFlex base

BINDINGS

ART.N°: 100514 PRD 14 S BRAKE 88 [F]

i.SUPERSHAPE RALLY

LIKE ITS NAME SUGGESTS, THIS SKI IS THE PERFECT ALLROUNDER.



ART.N°: 310184

FEATURES

KERS • ERA 3.0 S • Race structured UHM C base • WC sandwich cap construction
• Speed Rocker

LENGTHS

149/156/163
170/177

DIMENSIONS

131/76/109
@ length 170

RADIUS

13,6 @ length 170

PLATES

TriFlex base

BINDINGS

ART.N°: 100522 PRX 12 S

i.SUPERSHAPE MAGNUM

A FAST YET MANAGEABLE, FULLY EQUIPPED SPEED MACHINE. FOR ALL DAY ON PISTE SKIERS.



ART.N°: 310124

FEATURES

KERS • ERA 3.0 S • Race structured UHM C base • WC sandwich cap construction
• Speed Rocker

LENGTHS

149/156/163
170/177

DIMENSIONS

128/72/106
@ length 170

RADIUS

13,1 @ length 170

PLATES

TriFlex base

BINDINGS

ART.N°: 100522 PRX 12 S

i.SUPERSHAPE SPEED

THE PURELY RACE CARVE ORIENTED SUPERSHAPE WITH ITS LEGENDARY RACE ORIENTED SIDECUT.



ART.N°: 310154

FEATURES

KERS • ERA 3.0 S • Race structured UHM C base • WC sandwich construction • Speed Rocker

LENGTHS

156/163/170/177/184

DIMENSIONS

119/66/98
@ length 170

RADIUS

14,3 @ length 170

PLATES

TriFlex base

BINDINGS

ART.N°: 100513 PRD 14 S

PRESTIGE

A REAL HIGH-END PRODUCT. TECHNOLOGY AND DESIGN AT IT'S BEST, A GUARANTEE FOR MAXIMUM SKIING PLEASURE.



ART.N°: 310404

FEATURES

ERA 3.0 S • Intelligence™ Chip Technology • WC sandwich cap construction • Metal Power Tubes • Race structured UHM C base • Speed Rocker

LENGTHS

149/156/163/170/177

DIMENSIONS

131/76/109
@ length 170

RADIUS

13,6 @ length 170

PLATES

TriFlex base

BINDINGS

ART.N°: 100430 PRD 14

PREMIUM

THE STATE OF THE ART. THE PERFECT COMBINATION OF HEAD'S MOST BRILLIANT TECHNOLOGIES, PACKED INTO A SOPHISTICATED DESIGN.



ART.N°: 310424

FEATURES

Intelligence™ Chip Technology • WC sandwich construction • Metal Power Tubes • Race structured UHM C base

LENGTHS

156/163/170/177

DIMENSIONS

119/66/98
@ length 170

RADIUS

14,3 @ length 170

PLATES

TriFlex base

BINDINGS

ART.N°: 100430 PRD 14

REV 105

KNOWN AS THE BULLDOZER,
THIS SKI WILL TAKE THROUGH MOST POWDER DAYS.



ART.N°: 310504

FEATURES

Allride Rocker • ER A 3.0 • Sandwich cap construction • Structured UHM C base

LENGTHS

171 / 181 / 191

DIMENSIONS

144 / 105 / 131 @ length 181

RADIUS

16,0 @ length 181

BINDINGS

ART.N°: 111604 TYROLIA AAADRENALIN 16 SHORT
ART.N°: 111615 TYROLIA AAATTACK 16

REV 90

WHATEVER THE TERRAIN, SNOW TYPE, OR SKIER TYPE.
THIS REVOLUTIONARY SKI CAN DO IT ALL.



ART.N°: 310544

FEATURES

Allride Rocker • ER A 3.0 • Sandwich cap construction • Structured UHM C base

LENGTHS

149 / 156 / 163 / 170 / 177 / 184

DIMENSIONS

136 / 91 / 117 @ length 177

RADIUS

16,6 @ length 177

BINDINGS

ART.N°: 111616 TYROLIA AAATTACK 13 BRAKE 97 [A]

REV 85 PRO

EITHER A FREERIDER WHO ALSO LIKES TO CARVE, OR A CARVER WHO LIKES TO FREERIDE EVERY NOW AND THEN, THIS IS YOUR SKI.



ART .N°: 310564

FEATURES

Allride Rocker • ER A 3.0 • Sandwich cap construction • Structured UHM C base Also available without PowerRail (Art.No: 310574)

LENGTHS

163 / 170 / 177 / 184

DIMENSIONS

132 / 86 / 114 @ length 177

RADIUS

15,9 @ length 177

BINDINGS

ART.N°: 100521 PRD 12 BRAKE 88 [F]

PLATES

PowerRail

REV 80 PRO

DON'T KNOW WHERE TO SKI WHEN YOU LEAVE THE HOUSE? INSPIRED BY ALL KINDS OF TERRAIN? THEN THIS IS THE SKI FOR YOU.



ART .N°: 310584

Allride Rocker • ER A 3.0 • Sandwich cap construction • Structured UHM C base

LENGTHS

156 / 163 / 170 / 177 / 184

DIMENSIONS

130 / 81 / 112 @ length 177

RADIUS

14,8 @ length 177

PLATES

PowerRail

BINDINGS

ART .N°: 100567 PR 11 BRAKE 90 [G]

REV 78

THE 78 WIDTH IS THE CHOICE OF ALL MOUNTAIN RIDERS WHO SPEND MOST OF THEIR TIME ON THE GROOMED.



ART.N°: 310604

FEATURES

Allride Rocker • ER A 3.0 • Power Sidewall Jacket
• Structured UHM C base

LENGTHS

142 / 149 / 156 / 163 / 170 / 177

DIMENSIONS

127 / 78 / 110 @ length 170

RADIUS

13,6 @ length 170

PLATES

PowerRail

BINDINGS

ART .N°: 100567 PR 11 BRAKE 90 [G]

REV 75

THIS SKI IS THE RIGHT CHOICE FOR ALL-MOUNTAIN-RIDERS, WHO APPRECIATE A GOOD CARVING-PERFORMANCE.



ART.N°: 310624

FEATURES

Allride Rocker • ER A 3.0 • Power Carbon Jacket • Structured UHM C base

LENGTHS

149 / 156 / 163 / 170 / 177

DIMENSIONS

125 / 75 / 109 @ length 170

RADIUS

13,5 @ length 170

PLATES

PowerRail

BINDINGS

ART .N°: 100527 PR 11

INTEGRALE 1000

FOR PERFORMANCE SCHIZOPHRENICS: HARD PACK OR ICY CONDITIONS, THIS SKI CAN SKI THEM ALL.



INTEGRALE 800

FOR TRUE ALL-ROUNDERS. THIS SKI IS PERFECT FOR EASY RIDES ON SUNNY SUNDAY AFTERNOONS.



INTEGRALE 600

MADE FOR COMFORT-ORIENTED EASY RIDERS, WHO EVERY NOW AND THEN LIKE SOME CARVING ACTION.



ART.N°: 310304

FEATURES

Allride Rocker • ERA 3.0 • Sandwich Cap Construction • Race structured UHM C base • Diffusor

LENGTHS

149/156/163/170/177

DIMENSIONS

127/75/111 @ length 170

RADIUS

13,2 @ length 170

PLATES

PowerRail

BINDINGS

ART .N°: 100528 PR 11

ART.N°: 310324

FEATURES

Allride Rocker • ERA 3.0 • Sandwich Cap Construction • Race structured UHM C base • Diffusor

LENGTHS

149/156/163/170/177

DIMENSIONS

125/72/109 @ length 170

RADIUS

12,9 @ length 170

PLATES

PowerRail

BINDINGS

ART .N°: 100527 PR 11

ART.N°: 310344

FEATURES

Allride Rocker • ERA 3.0 • Power Sidewall Jacket • Structured UHM C base

LENGTHS

149/156/163/170/177

DIMENSIONS

127/74/110 @ length 170

RADIUS

13,0 @ length 170

PLATES

PowerRail

BINDINGS

ART .N°: 100384 PR 11

TURBINE 125

WITH FLOAT AND POWER, TURBINE IS YOUR ENGINE FOR THOSE DAYS YOU'LL REMEMBER FOREVER.



ART.N°: 311324

FEATURES

Sandwich Cap Construction • Structured Diecut UHM C base • Tuffwalls • ISS-Independent Suspension System • TNT Rocker • TTS

LENGTHS

181/191

DIMENSIONS

148/124/133 @ length 181

RADIUS

19,0 @ length 181

BINDINGS

ART.N°: 111605 TYROLIA AAADRENALIN 16 LONG
ART.N°: 111607 TYROLIA AAADRENALIN 13 LONG

CYCLIC 115

AGILITY, VERSATILITY AND CONTROL THAT WILL GIVE YOU THE SAME IMPRESSIVE FEELING LIKE YOUR FIRST FLIGHT IN A HELICOPTER.



ART.N°: 311304

FEATURES

Sandwich Cap Construction • Structured Diecut UHM C base • Tuffwalls • ISS-Independent Suspension System • TNT Rocker • TTS

LENGTHS

171/181/191

DIMENSIONS

148/113/131 @ length 181

RADIUS

19,0 @ length 181

BINDINGS

ART.N°: 111615 TYROLIA AAATTACK 16

COLLECTIVE 105

SURE TO IMPRESS A RIDER ON GROOMED SNOW, YET ALLOW THE ADVENTUROUS SPIRIT TO FLY AND EXPLORE.



ART.N°: 311344

FEATURES

Sandwich Cap Construction • Structured Diecut UHM C base • Tuffwalls • ISS-Independent Suspension System • Allride Rocker • TTS

LENGTHS

171/181/191

DIMENSIONS

146/105/128 @ length 181

RADIUS

17,5 @ length 181

BINDINGS

ART.N°: 111606 AAADRENALIN 13 SHORT
ART.N°: 111607 AAADRENALIN 13 LONG
ART.N°: 111604 AAADRENALIN 16 SHORT

VENTURI 95

A CARVING SKI ON GROOMED SLOPES, WITH SOME ADDITIONAL FLOTATION AND FORGIVENESS IN VARIED CONDITIONS.



ART.N°: 311364

FEATURES

Sandwich Cap Construction • Structured Diecut UHM C base • Tuffwalls • ISS-Independent Suspension System • TNT Rocker • TTS

LENGTHS

161 / 171 / 181 / 191

DIMENSIONS

140 / 95 / 126 @ length 181

RADIUS

16,0 @ length 181

BINDINGS

ART.N°: 111616 TYROLIA AAATTACK 13 BRAKE 97 [A]



PROTOSTELLAR 98

A TOOL FOR ADVENTURE, READY FOR ALL CONDITIONS. EFFORTS GOING UP WILL BE REALLY ENJOYED ON THE WAY DOWN.



ART.N°: 310704

FEATURES

ERA 3.0 • Sandwich cap construction • Nano Tech surface • Highly transparent UHM base • Allride Rocker • Skins need to be ordered separately (Art.N°: 388123)

LENGTHS

156/163/170/177/184

DIMENSIONS

138/99/124 @ length 177

RADIUS

17,2 @ length 177

BINDINGS

ART.N°: 111612 TYROLIA AAAMBITION 12 SOLID BLUE/YELLOW
ART.N°: 111716 TYROLIA AAAMBITION 10 SOLID WHITE/BLACK

GALACTIC 84

HYBRID SHAPE MAKES THIS SKI YOUR LIGHT WEIGHT ANSWER TO GET TO THE TOP WITHOUT SACRIFICING PERFORMANCE ON THE WAY DOWN.



ART.N°: 310734

FEATURES

ERA 3.0 • Sandwich cap construction • Nano Tech surface • Highly transparent UHM base • Allride Rocker • Skins need to be ordered separately (Art.N°: 388123)

LENGTHS

149/156/163/170/177/184

DIMENSIONS

135/85/117 @ length 177

RADIUS

15,6 @ length 177

BINDINGS

ART.N°: 111612 TYROLIA AAAMBITION 12 SOLID BLUE/YELLOW
ART.N°: 111716 TYROLIA AAAMBITION 10 SOLID WHITE/BLACK

NEBULA 78

CLASSIC EXPLORING SKI WITH A LIGHTWEIGHT DESIGN WITH ENHANCED DOWNHILL PERFORMANCE.



ART.N°: 310754

FEATURES

ERA 3.0 • Wood core cap construction • Nano Tech surface • Highly transparent UHM base • Allride Rocker • Skins need to be ordered separately (Art.N°: 388123)

LENGTHS

142/149/156/163/170/177

DIMENSIONS

131/78/113 @ length 170

RADIUS

13,2 @ length 170

BINDINGS

ART.N°: 111612 TYROLIA AAAMBITION 12 SOLID BLUE/YELLOW
ART.N°: 111716 TYROLIA AAAMBITION 10 SOLID WHITE/BLACK



ALL COUNTRY SKINS

Composition: 65% Mohair and 35% Nylon

THE CADDY

THIS SKI IS A WEAPON FOR THE PARK, PIPE AND MORE. WITH MANY JOURNEYS TO THE TOP OF PODIUMS, THIS SKI HAS BEEN PROVEN TO PERFORM.



ART.N°: 311444

FEATURES

Sandwich twintip construction
 • Highly transparent UHM base • Tuffwalls • ISS -
 Independent Suspension System • PNP Rocker

LENGTHS

171 / 176 / 181

DIMENSIONS

120 / 84 / 109 @ length 176

RADIUS

19,0 @ length 176

BINDINGS

ART.N°: 111615 TYROLIA AAATTACK 16
 ART.N°: 111620 TYROLIA PEAK 18 X
 ART.N°: 111617 TYROLIA AAATTACK 13

FRAMEWALL

THE FIRST PARK SKI WITH A ROLL CAGE.



ART.N°: 311404

FEATURES

FrameWall • Sandwich twintip construction
• Highly transparent UHM base • ISS -
Independent Suspension System • PNP Rocker

LENGTHS

176 / 181

DIMENSIONS

121 / 84 / 110 @ length 181

RADIUS

20,2 @ length 181

BINDINGS

ART .N°: 111615 TYROLIA AAATTACK 16

OBLIVION

WIDER FOUNDATION FOR FLOAT IN VARIED CONDITIONS -
THEN TAKE A FEW LAPS IN THE PARK. NO WORRIES.



ART.N°: 311424

FEATURES

Sandwich Twintip Construction • Highly
transparent UHM base • Tuffwalls • ISS
- Independent Suspension System • PNP
Rocker

LENGTHS

171 / 176 / 181

DIMENSIONS

132 / 90 / 119 @ length 181

RADIUS

18,0 @ length 181

BINDINGS

ART.N°: 111616 TYROLIA AAATTACK 13 BRAKE 97 [A]
ART.N°: 111615 TYROLIA AAATTACK 16

THE SHOW

DURABLE CAP CONSTRUCTION MAKES FOR A LIGHTWEIGHT
TOOL READY FOR THE PROGRESSION FOR FREESKIING.



ART.N°: 311464

FEATURES

Sandwich Twintip Construction
• Highly transparent UHM base
• PNP Rocker

LENGTHS

154 / 163 / 172 / 181

DIMENSIONS

112 / 79 / 106 @ length 172

RADIUS

19,1 @ length 172

BINDINGS

ART.N°: 111617 TYROLIA AAATTACK 13

BIG JOY

WITH THIS SKI, WHEN YOU FLOAT SO EASILY IN POWDER YOU WANT BE ABLE TO TAKE THAT SMILE OF JOY FROM YOUR FACE.

 Light done right.



ART.N°: 311664

FEATURES

LIBRA: Graphene, Women's Camber, ERA 3.0

- Super Light Weight Distribution
- structured UHM C base • Allride Rocker
- Superlite sandwich cap construction

LENGTHS

158/168/178

DIMENSIONS

149/110/132 @ length 168

RADIUS

14,8 @ length 168

BINDINGS

ART.N°: 111722 TYROLIA AAATTACK 12 BRAKE 115 [A]





GREAT JOY

A NEW KIND OF EASY GOING SKI, AND WHEN PROMPTED ON POWDER, YOU'LL FEEL IN COMPLETE CONTROL.



ART.N°: 311644

FEATURES

LIBRA: Graphene • Women's Camber
 • ERA 3.0 • Super Light Weight Distribution
 • structured UHM C base • Allride Rocker
 • Super Lite Sandwich Cap Construction

LENGTHS

153 / 158 / 163 / 168 / 173

RADIUS

14,3 @ length 168

DIMENSIONS

141 / 98 / 124 @ length 168

BINDINGS

ART.N°: 111722 TYROLIA AAATTACK 12 BRAKE 115 [A]

TOTAL JOY

THIS ALL-MOUNTAIN SKI IS SO LIGHT, YET ITS PERFORMANCE WILL MAKE YOU CHILL EVEN WHEN YOU'RE RIPPING.



ART.N°: 311624

FEATURES

LIBRA: Graphene • Women's Camber • ERA 3.0
• Super Light Weight Distribution • Koroyd-Carbon Construction • structured UHM C base • Allride Rocker

LENGTHS

148/153/158/163/168

RADIUS

13,6 @ length 163

BINDINGS

ART.N°: 100573 JOY 11 SLR BRAKE 90 [H]

DIMENSIONS

133/85/113 @ length 163

PLATES

SuperLiteRail

SUPER JOY

THE UNIQUE SUPERLITE WOMEN'S SKI ARCHITECTURE WILL GIVE DARING WOMEN HIGH-CLASS HIGH-SPEED-CARVING EMOTIONS ON ANY GROOMED SLOPE.



ART.N°: 311604

FEATURES

LIBRA: Graphene • Women's Camber • ERA 3.0
• Super Light Weight Distribution • KORROYD Carbon Construction • structured UHM C base • Allride Rocker

LENGTHS

143/148/153/158/163/168

DIMENSIONS

128/75/108 @ length 163

RADIUS

12,5 @ length 163

PLATES

SuperLiteRail

BINDINGS

ART.N°: 100574 JOY 11 SLR BRAKE 78 [H]

ABSOLUT JOY

THE ABSOLUTE IN LIGHTNESS, BALANCE AND CONTROL, YOU WILL ENJOY EVERY SLOPE YOU HIT.



ART.N°: 311684

FEATURES

- LIBRA: Graphene • Women's Cambe • ERA 3.0
- Super Light Weight Distribution • Power Sidewall Jacket • Superlite Composite Core
- Highly transparent UHM base • Allride Rocker

LENGTHS

143/148/153/158/163/168

DIMENSIONS

129/79/109 @ length 163

RADIUS

13,5 @ length 163

PLATES

SuperLiteRail

BINDINGS

ART.N°: 100575 JOY 9 SLR BRAKE 90 [H]

PURE JOY

SKIING IS THE ESSENCE OF JOY, AND THIS SKI WILL ASSURE YOU GET PLENTY OF IT. AN EASY GOING AND ALWAYS IN CONTROL SKI, FOR NEW COMERS.



ART.N°: 311704

FEATURES

- LIBRA: Graphene • Women's Camber • ERA 3.0 • Super Light Weight Distribution • Power Sidewall Jacket • Highly transparent UHM base
- Allride Rocker

LENGTHS

143/148/153/158/163

DIMENSIONS

127/73/107 @ length 158

RADIUS

10,9 @ length 158

PLATES

SuperLiteRail

BINDINGS

ART.N°: 100576 JOY 9 SLR BRAKE 78 [H]

WORLD CUP REBELS i.SG RD

IF THE WORLD JUST SPINS TO SLOW FOR YOU, THEN THIS IS THE SKI THAT WILL SPEED IT UP.



ART.N°: 319974 (LENGTH 195)
ART.N°: 319984 (LENGTH 185)
ART.N°: 319994 (LENGTH 175)

FEATURES

- KERS
- Intelligence Technology
- WC Sandwich Construction
 - RD racing top sheet
- Race structured high speed
 - UHM C base
 - Rebel Camber
 - FIS approved

LENGTHS

195/185/175

DIMENSIONS

98/66/82 @ length 195
98/65/81 @ length 185
93/65/82 @ length 175

RADIUS

33,0 @ length 195
30,0 @ length 185
27,0 @ length 175

PLATES

Junior Raceplate

BINDINGS

ART.N°: 100500 FREEFLEX PRO 20 X RD
ART.N°: 100502 FREEFLEX PRO 18 X
ART.N°: 100505 FREEFLEX PRO 16 RD/EP



WORLD CUP i.GS TEAM

FOR THE NEXT GENERATION OF WILD AT HEART PERFORMERS.



ART.N°: 314014

FEATURES

Intelligence Technology • WC Sandwich Construction • RD racing top sheet • Race structured UHM C base • Rebel Camber

LENGTHS

123 / 130 / 137 / 144 / 151 / 158 / 165 / 172

DIMENSIONS

99 / 64 / 86 @ length 144

RADIUS

14,2 @ length 144

PLATES

Raceplate Junior

BINDINGS

ART.N°: 100510 FREEFLEX PRO 11

WORLD CUP i.SL TEAM

A SUPER AGILE AND SUPER RESILIENT SLALOM SKI WITH GREAT EDGE GRIP FOR TODAY'S TALENT AND TOMORROW'S WINNERS.



ART.N°: 314034

FEATURES

Intelligence Technology • WC Sandwich Construction • RD racing top sheet • Race structured UHM C base • Rebel Camber

LENGTHS

121 / 131 / 136 / 141 / 146 / 151 / 156

DIMENSIONS

110 / 63 / 96 @ length 141

RADIUS

10,3 @ length 141

PLATES

Raceplate Junior

BINDINGS

ART.N°: 100510 FREEFLEX PRO 11

WORLD CUP i.RACE

THE ULTIMATE TOY FOR YOUNG SPEEDSTERS:
EXTREMELY STABLE AT HIGH SPEEDS.



ART.N°: 314124

FEATURES

- Intelligence Technology
- WC sandwich construction
- UHM C base
- Structured surface

LENGTHS

100/110/120/130/140/150/160

DIMENSIONS

111/67/95 @ length 140

RADIUS

10,8 @ length 140

BINDINGS

ART.N°: 100547 SX9 JR RACE

SUPERSHAPE LR

THE EARLY RIDER CATCHES THE CUP: THE SUPERSHAPE LR
ENSURES A PERFECT START, FROM THE START.



ART.N°: 314134

FEATURES

- Wood core cap construction
- Structured surface
- UHM C base

LENGTHS

120/130/140/150/160

DIMENSIONS

112/65/96 @ length 140

RADIUS

9,7 @ length 140

PLATES

LiteRail

BINDINGS

ART.N°: 100436 LRX 7.5 AC

SUPERSHAPE TEAM LR

THE PERFECT STARTER KIT FOR THE EAGER JUNIORS.



ART.N°: 314154

FEATURES

- Jr. Power Frame • ERA 2.0 • E base black
- Structured surface • Also available without LiteRail from length 67 - 157 (ART.N: 314144)
- Junior Rocker

LENGTHS

87/97/107/117/127/137/147/157

DIMENSIONS

111/67/96 @ length 127

RADIUS

8,0 @ length 127

PLATES

LiteRail

BINDINGS

ART.N°: 100441 LRX 4.5 AC (87/97)
ART.N°: 100436 LRX 7.5 AC (107-157)

ETHAN TOO

WITH THIS SKI, EVERY JUNIOR CAN BECOME A HEADLINER. THE YOUNGER, THE BETTER!



ART.N°: 314044

FEATURES

- Sandwich cap construction
- Highly transparent UHM base
- Tuffwalls • ISS-Independent Suspension TNT Rocker • TTS

LENGTHS

141 / 151 / 161 / 171

DIMENSIONS

137 / 93 / 123 @ length 161

RADIUS

12,3 @ length 161

BINDINGS

ART.N°: 111726 TYROLIA PEAK 11 W/O BRAKE [E] (151/161/171)
ART.N°: 111627 TYROLIA PEAK 7.5 AC BRAKE 90 [J] (141)

THE JR CADDY

ITS HABITAT IS THE PARKS AND PIPES OF THIS WONDERFUL WHITE PLANET.



ART.N°: 314064

FEATURES

- Sandwich twintip construction
- Highly transparent UHM base
- Tuffwalls • PNP Rocker

LENGTHS

131 / 141 / 151 / 161

DIMENSIONS

116 / 81 / 106 @ length 141

RADIUS

11,8 @ length 141

BINDINGS

ART.N°: 111627 TYROLIA PEAK 7.5 AC BRAKE 90 [J] (131/141)
ART.N°: 111624 TYROLIA PEAK 11 BRAKE 90 [E] (151/161)

RESIDUE

CATCH UP TO THE BIG BOYS ON EVERY PARK AND PIPE DAY.



ART.N°: 314084

FEATURES

- Twintip construction • Highly transparent UHM base • Structured surface • PNP Rocker

LENGTHS

118 / 127 / 136 / 145 / 154

DIMENSIONS

109 / 77 / 103 @ length 145

RADIUS

13,4 @ length 145

BINDINGS

ART.N°: 111627 TYROLIA PEAK 7.5 AC BRAKE 90 [J] (118-136)
ART.N°: 111624 TYROLIA PEAK 11 BRAKE 90 [E] (145/154)

FIRST JOY

SKIING SHOULD ALL ABOUT JOY AND THIS SKI WITH MAKE YOU GIGGLE ALL THE WAY DOWN.



ART.N°: 314204

FEATURES

ERA 2.0 • Jr. Power Frame • E base black
• Also available without LiteRail from length 67 to 137 (Art. N. 314214) • Junior Rocker

LENGTHS

87/97/107/117/127/137

DIMENSIONS

111/67/96 @ length 127

RADIUS

8,0 @ length 127

PLATES

LiteRail

BINDINGS

ART.N°: 100572 JOY 4.5 AC LRX

SOUPEHEAD LR

THERE IS NO "I" IN TEAM: THIS PLAYER SHAPES UP FOR LITTLE RIDERS WITH BIGGEST AMBITIONS.



ART.N°: 314324

FEATURES

Twintip construction • E base black
• Structured surface • Also available without LiteRail (Art. N. 314314)

LENGTHS

87/97/107/117/127/137

DIMENSIONS

104/68/92 @ length 127

RADIUS

9,4 @ length 127

PLATES

LiteRail

BINDINGS

ART.N°: 100441 LRX 4.5 AC

PEZ TEAM

WHAT HAVE PEZ AND HEAD IN COMMON? THEY BOTH MAKE KIDS HAPPY, IT'S ALL ABOUT GETTING THAT BIG SMILE.



ART.N°: 314254

FEATURES

ERA 2.0 • Jr. Power Frame • E base black
• Comes with PEZ candy dispenser • Lengths 67 and 77 come without LiteRail • Junior Rocker

LENGTHS

67/77/87/97/107/117/127/137

DIMENSIONS

111/67/96 @ length 127

RADIUS

8,0 @ length 127

PLATES

LiteRail

BINDINGS

ART.N°: 100441 LRX 4.5 AC (87-137)
ART.N°: 111557 TYROLIA SX 4.5 AC (67/77)

WHEN A PERFECT SOUL FINDS A PERFECT BODY.

What's Your Limit?



BODY&SOUL THE PERFECT SYNERGY!

TECHNOLOGY

BOOTS

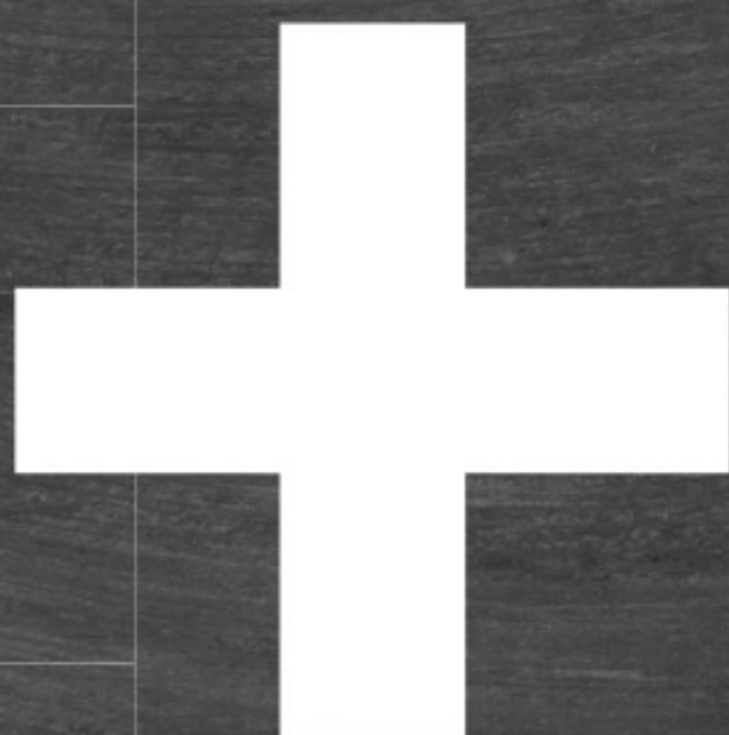

PERFECT FIT

PERFECT FIT IS THE EXCLUSIVE 100% CUSTOMIZABLE INNERBOOT THAT PROVIDES THE BEST LEVEL OF PRECISION, COMFORT AND DURABILITY.

100% full customization:
The new innerboot perfectly adapts to the foot and shell.

Increased precision,
performance and comfort
durability.

Customization can be repeated
virtually without limitation.

ADAPTIVE FIT TECHNOLOGY

Adaptive Fit Technology is the first and only ski boot technology that lets you change the width of your boot from comfort/performance last to precision/performance last with the turn of a screw.

THE NEW HEAD 100% CUSTOMIZABLE INNERBOOT



WHAT IS IT?

Perfect Fit is a liner made entirely from a special blend of PE and EVA thermo-formable material that adapts to the individual foot (inside) and to the shell (outside). The tongue is also made with thermo-formable material to complete the customization.



Heat Fit



Full Custom Heat Fit

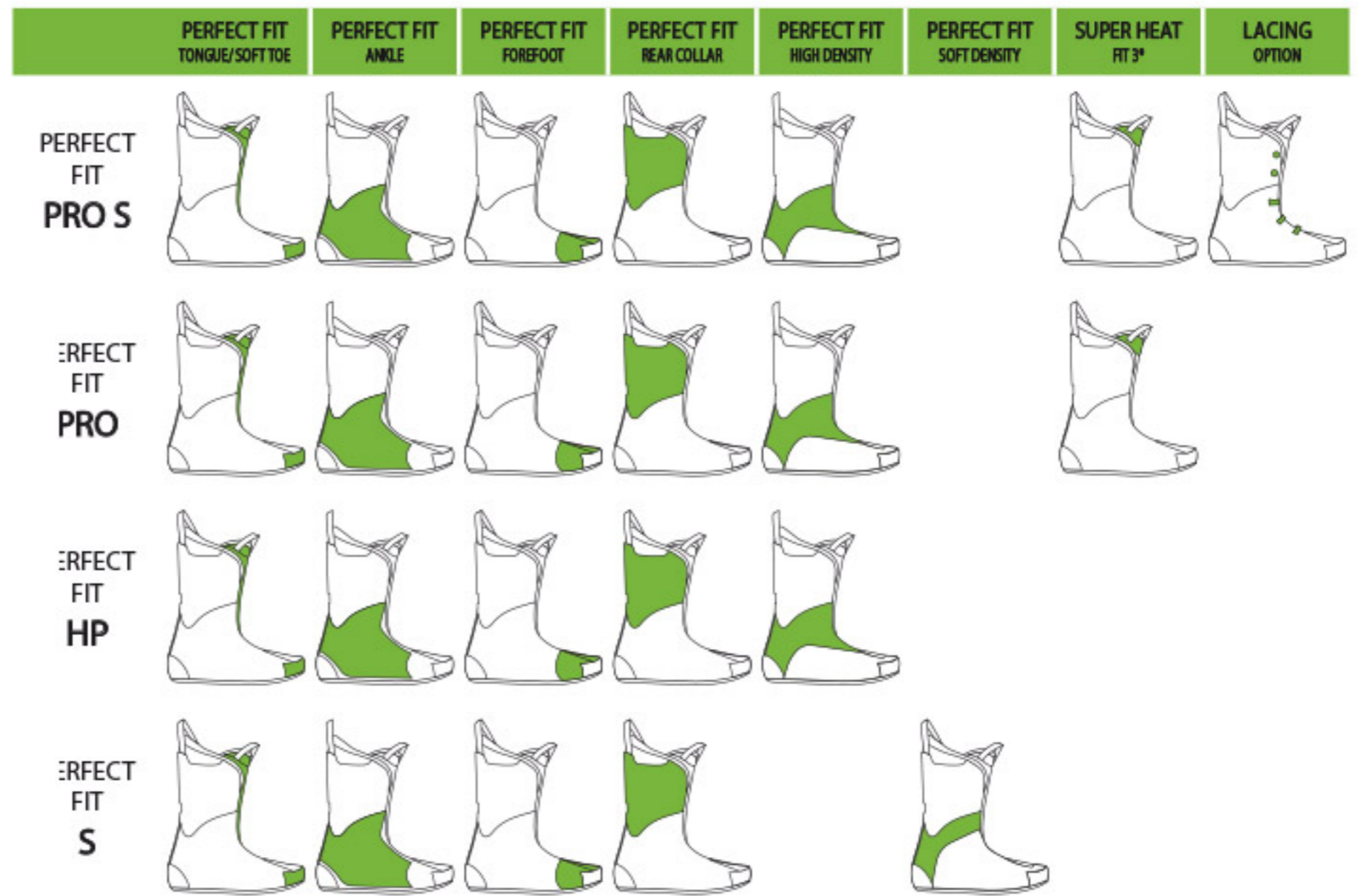

* Super Heat Fit 3: High Performance material featuring self-adapting padding on the tongue.

PERFECT FIT HIGH DENSITY CONSTRUCTION

Increased high density material on the medial and lateral aspects of the mid foot promote better performance and a more precise fit.



PERFECT FIT SOFT DENSITY CONSTRUCTION

By using a lower density material on the majority of the liner, a more comfortable, relaxed fit is guaranteed.



HOW TO CUSTOMIZE THE INNERBOOT

1 Warm up shell and liner for 5 minutes at 80 °C.



2 Step in and close the buckles.



3 In 10 minutes the customization is ready.



BOOT TECHNOLOGY / RAPTOR AND CHALLENGER

DOUBLE POWER BOOSTER VELCRO

The strap of the Double Power Booster Velcro works as a double pulley for better closure and a tighter wrapping on the cuff. The elastic Booster Strap allows more dynamical response of the boot. The result: more precise transmission and faster ski reaction. (Manufactured under license from Skimetrix Ltd.)

Protected under one or more of the following:
European patent N. 1087676,
US patent N. 6.026.594
Canadian patent N. 2.335.698.
Other patents pending.



OFFICIAL SUPPLIER OF GREAT TURNS



BOOT TECHNOLOGY / RAPTOR, CHALLENGER AND VECTOR

SPINEFLEX BUCKLES

Spineflex is a revolutionary buckle concept with a flexible element and a constant closure point. The flexible element allows the buckle to adapt to the shell profile and thus provide a homogeneous foot wrapping independent from the degree of closure. The increased precision and comfort created from the absence of pressure points results in better performance.

SPINEFLEX BUCKLE

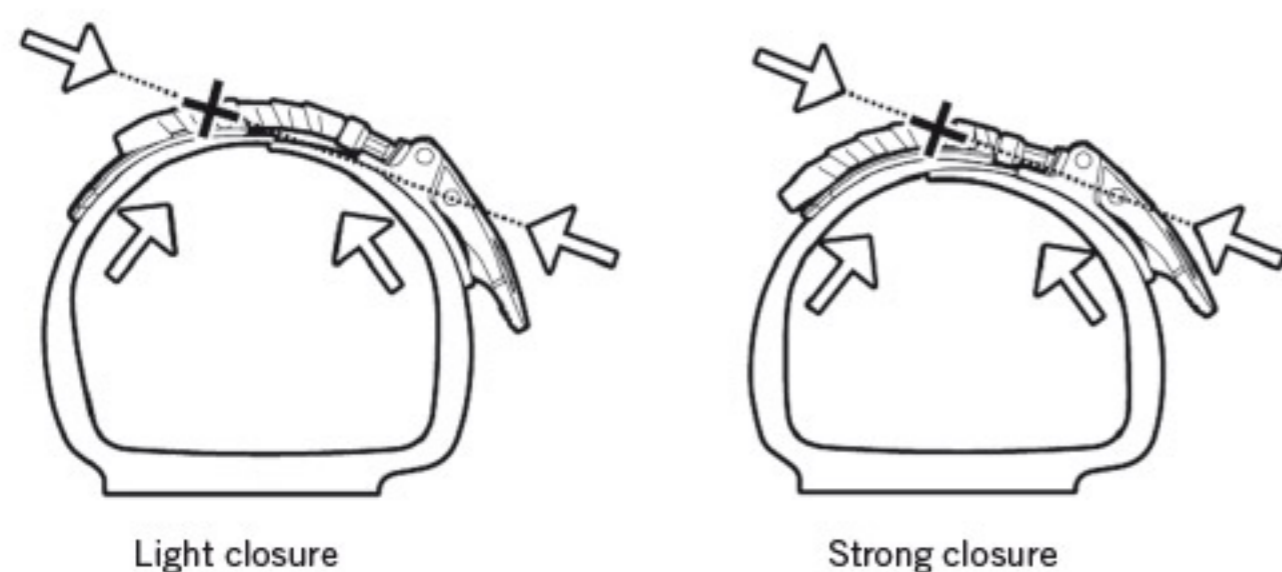

Light closure

Strong closure

NORMAL BUCKLE

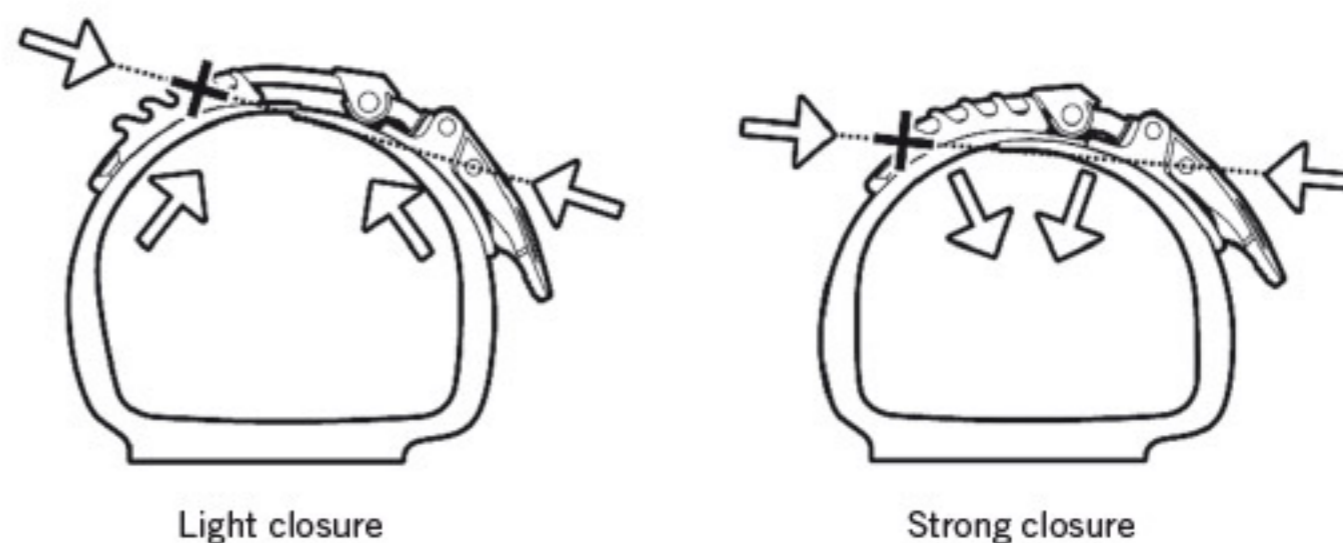

Light closure

Strong closure

BOOT TECHNOLOGY / CHALLENGER AND VECTOR

NEW DOUBLE POWER SPINEFLEX BUCKLES

New Double Power Spineflex Buckles is a revolutionary buckle concept with a flexible element and a constant closure point. The flexible element allows the buckle to adapt to the shell profile and thus provide a homogeneous foot wrapping independent from the degree of closure. The increased

precision and comfort created from the absence of pressure points results in better performance. The ergonomic, patented Double Power lever increases the leverage of the buckle by 50%, halving the effort required to buckle in constant release values.

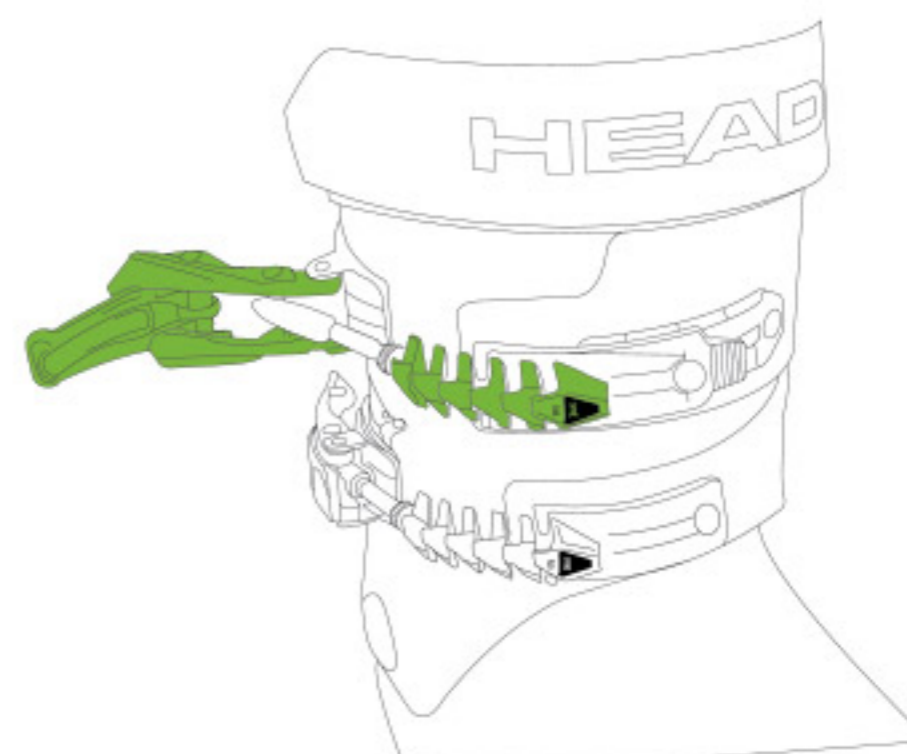

BOOT TECHNOLOGY / CHALLENGER, VECTOR, VENTURE, EDGE AND CUBE

Supermacro toothplate with a push of a simple button, the ratchet provides a 28mm range of adjustment granting to fit any leg.

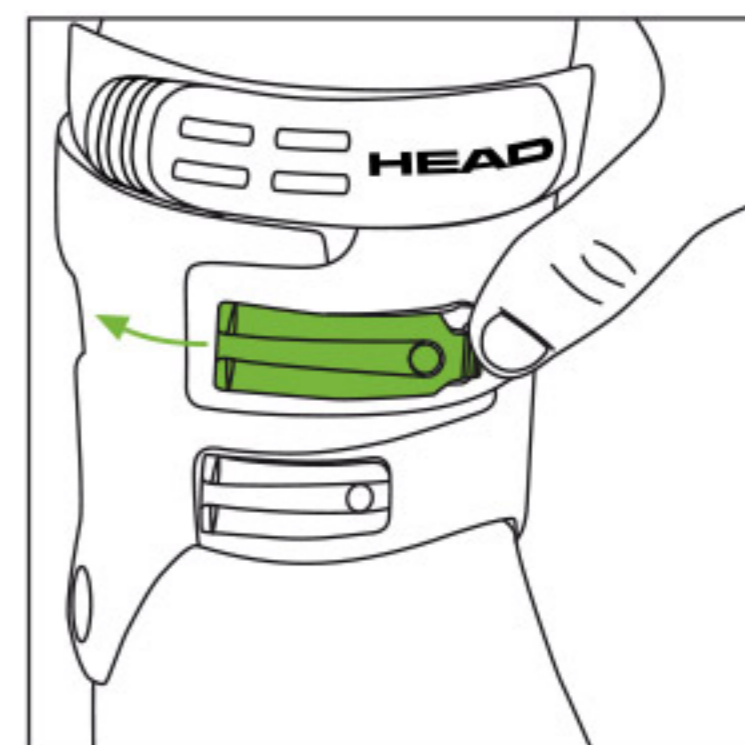

BOOT TECHNOLOGY / CHALLENGER AND ADAPT EDGE

ADAPTIVE FIT TECHNOLOGY

Adaptive Fit Technology is the first and only ski boot technology that lets you change the width of your boot from comfort/performance last to precision/performance last with the turn of a screw.

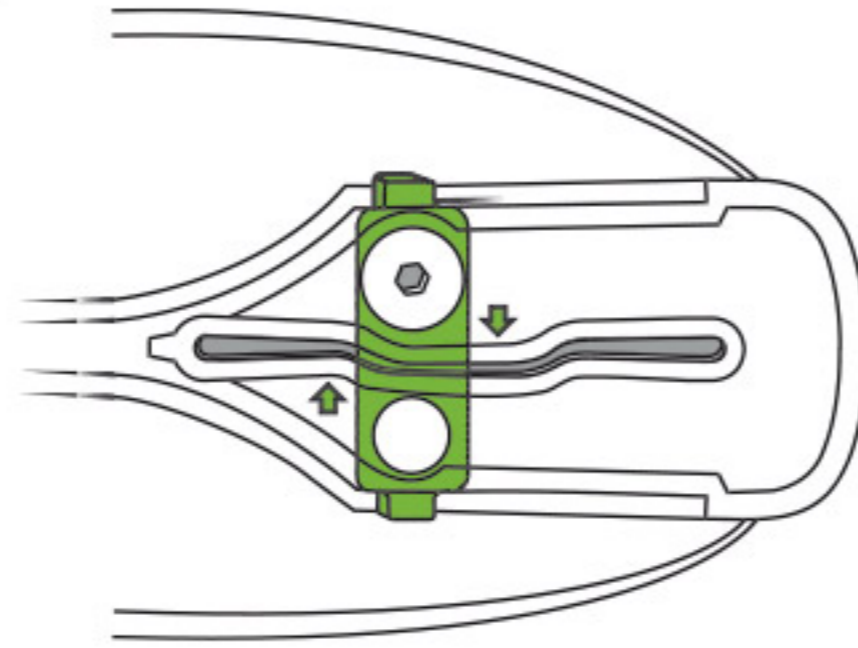

BOOT TECHNOLOGY / CHALLENGER

POWER SKI HIKE

Provides the easiest selection of ski and hike mode available. Easy to identify and operate, yet providing a powerful connection between the cuff and shell for maximum precision and impulse transmission.



BOOT TECHNOLOGY / VECTOR, CHALLENGER AND ADAPT EDGE

TRI (BI)-INJECTION FRAME

A high performance, multi-density shell that optimizes easy entry, foot wrapping, comfort and energy transmission.

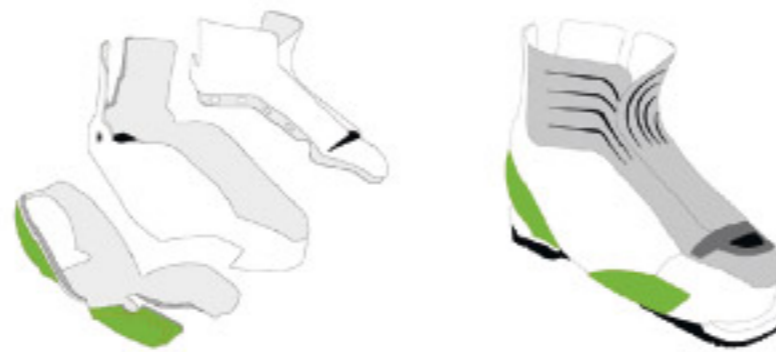

BOOT TECHNOLOGY / CHALLENGER, VECTOR AND EDGE

DOUBLE POWER SPINE-TECH BUCKLES

Spine-Tech buckles provide constant traction and avoid pressure points, improving both comfort and precision. The ergonomic, patented Double Power lever increases the leverage of the buckle by 50%, halving the effort required to buckle in constant release values.

BOOT TECHNOLOGY / CUBE

DEVELOPING OUR CUBE3 LINE, WE DECIDED TO TACKLE THE ONE CHALLENGE EVERY SKIER FACES EVERY DAY ON THE MOUNTAIN: TO COMBINE GREAT SKIING PERFORMANCE WITH GREAT WALKING PERFORMANCE. AFTER ALL, ON ANY GIVEN DAY, WE SPEND UP TO 30% OF OUR TIME OUTSIDE OF THE BINDING.

EASY IN

Developing our Cube3 line, we decided to tackle the one challenge every skier faces every day on the mountain: To combine great skiing performance with great walking performance. After all, on any given day, we spend up to 30% of our time outside of the binding.

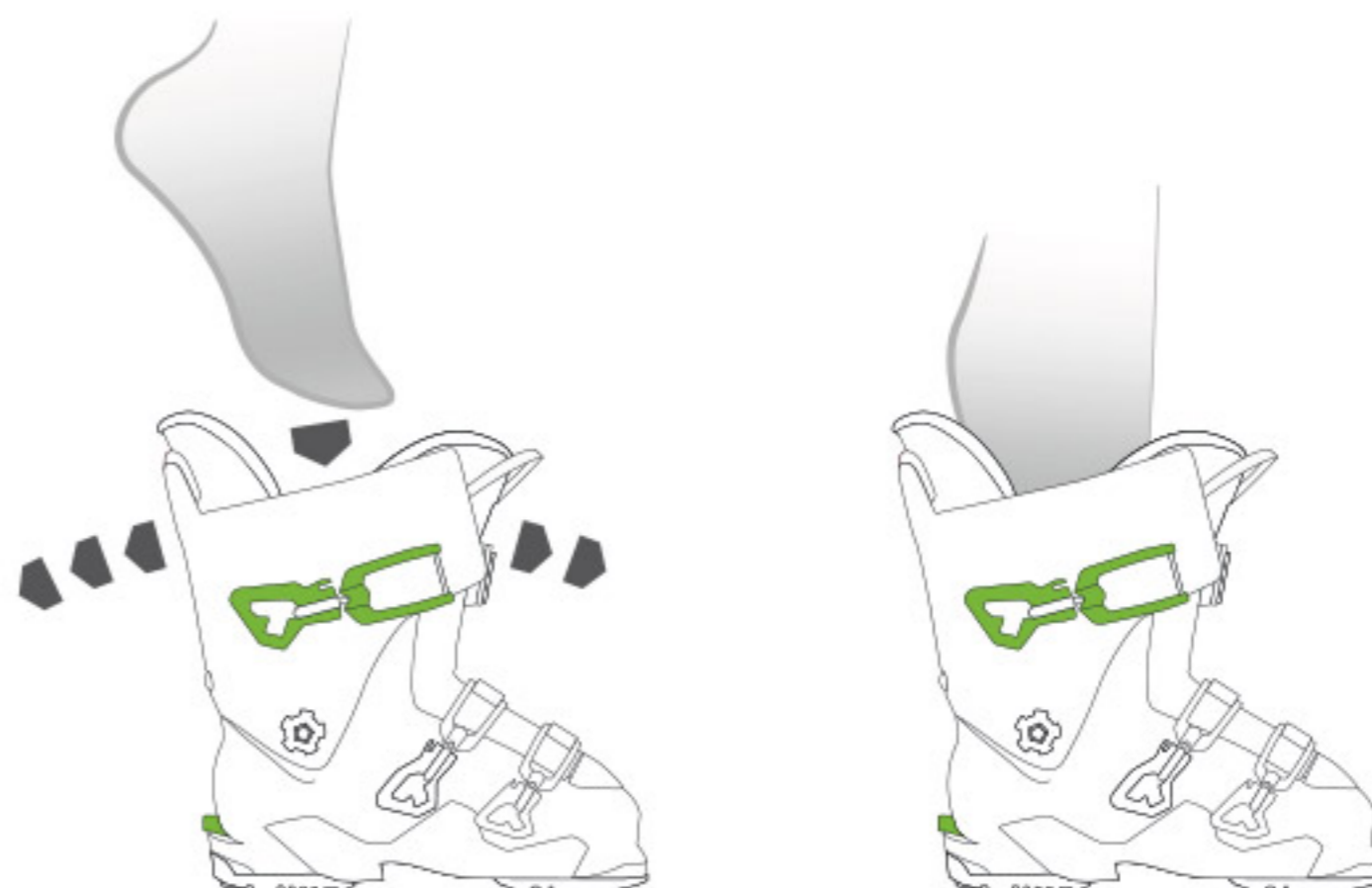

EASY WALK

Outside of the binding, the shaft of the Cube3 is always unlocked, allowing natural walking. This, in combination with (patented) SoftWalk heel and grip system on the heel, makes the Cube3 a superb walking boot.

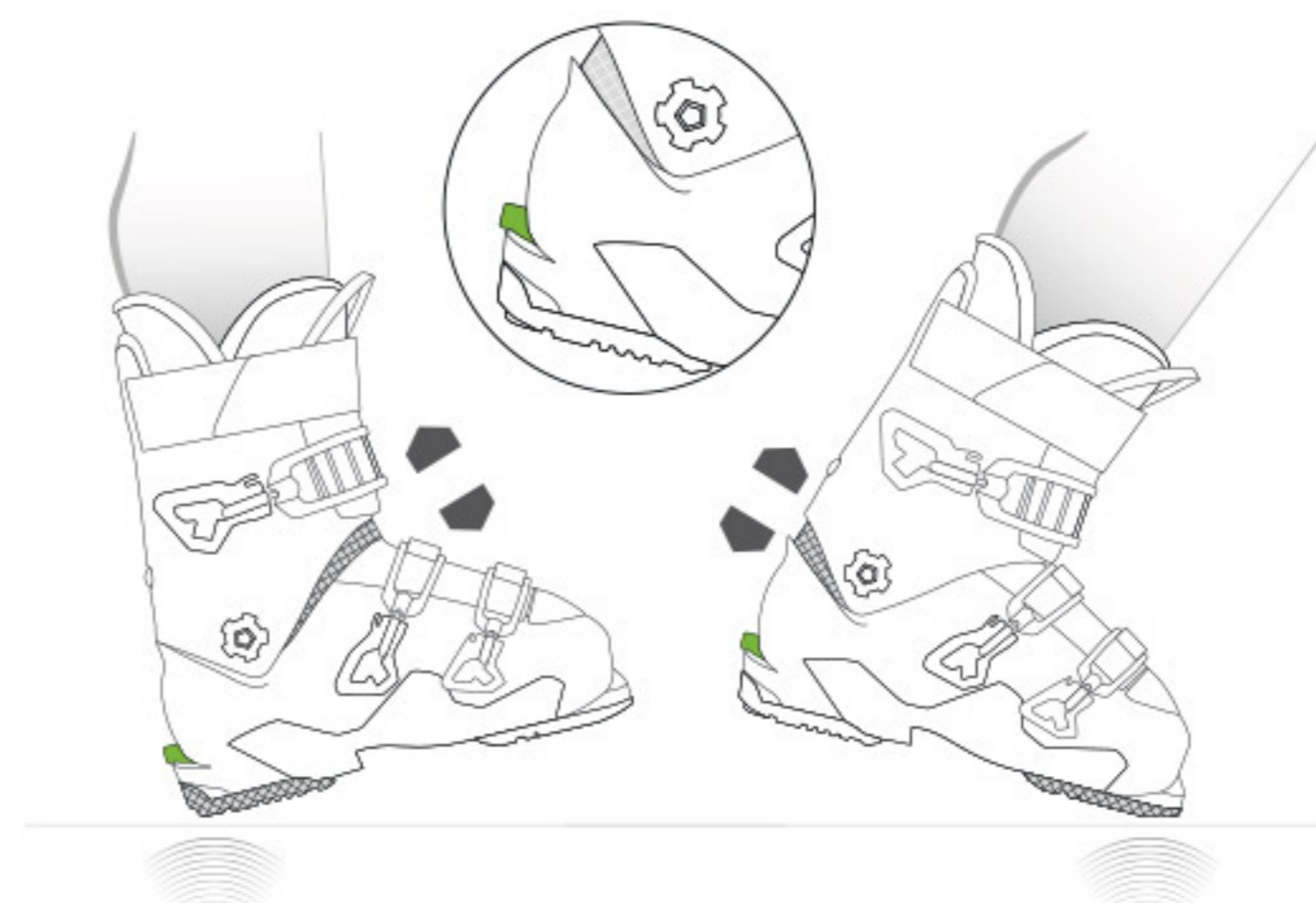

EASY SKI

The moment you step into your binding the patented integrated AutoSkiWalk mechanism blocks the shaft, allowing you to speed off down the mountain without bowing, bending or buckling.

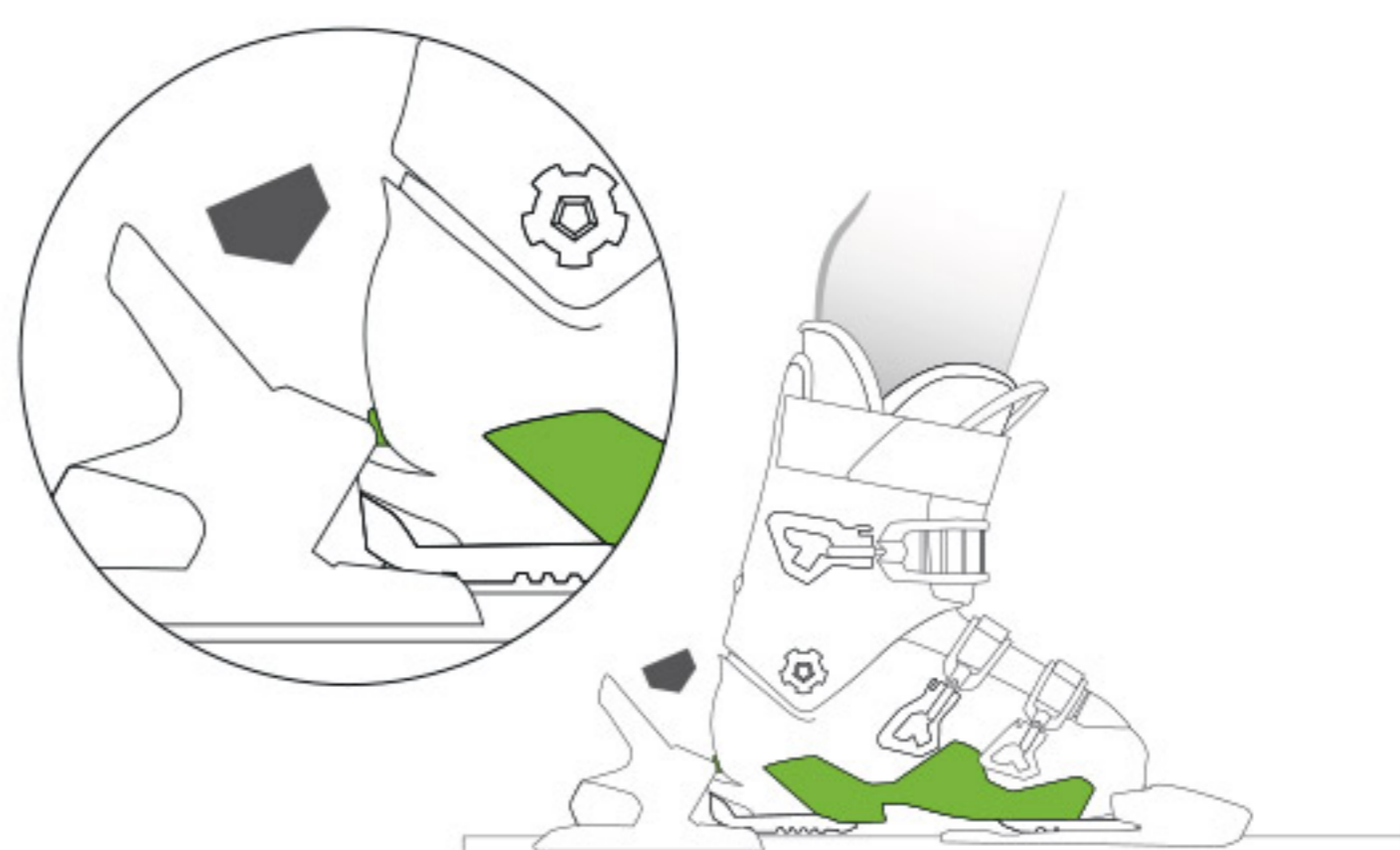

BOOT TECHNOLOGY / VENTURE

SKI / TOUR MECHANISM

The Ski / Tour mechanism is the right combination between skiing and touring. Providing a perfect lock of the shell during the downhill activities for the maximum performance, yet offering an easy release for the return trip.

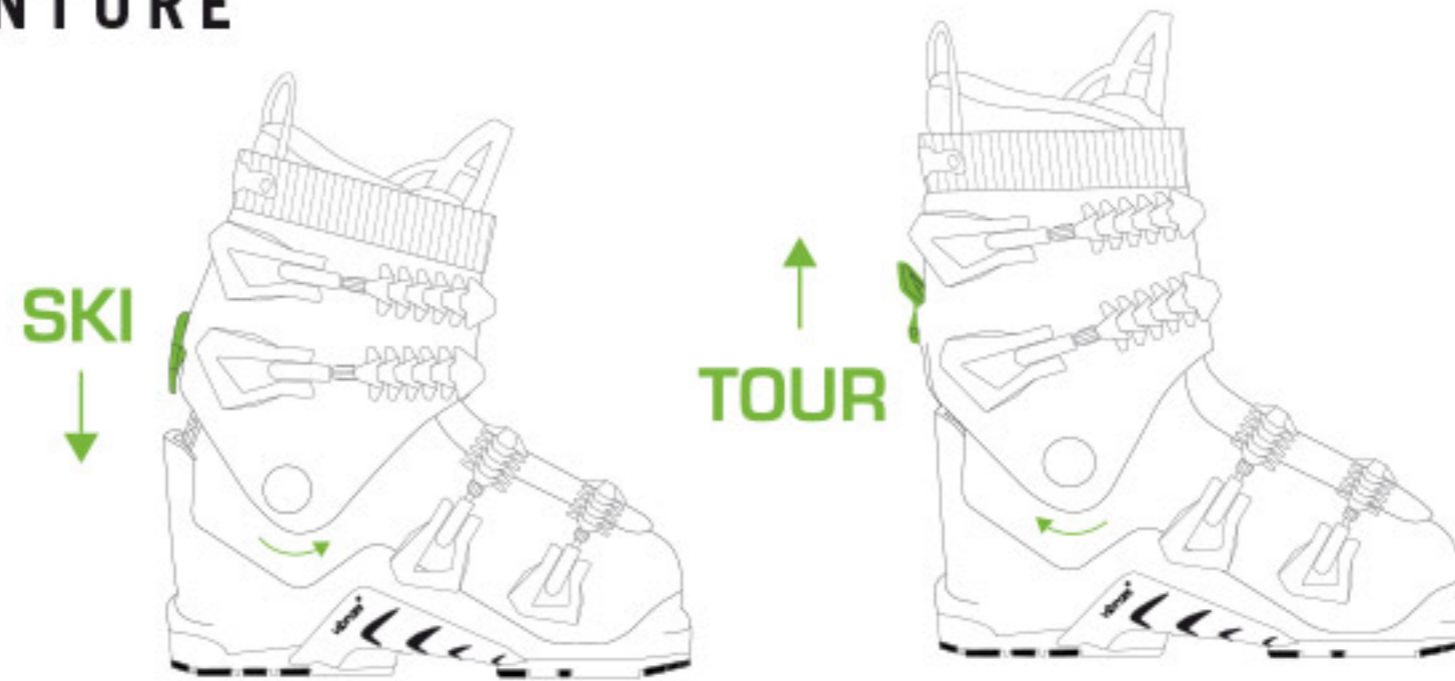

VIBRAM SOLE

The bi-injected Vibram® sole allows safe hiking on all terrain while reducing shock absorption as well.



VIBRAM TOURING PADS

Interchangeable Vibram® Touring Pads – an innovative high performance rubber sole provides the maximum grip when hiking on anything from rocks on a peak to the parking lot ice. Please refer to the international standard "ISO 9523".

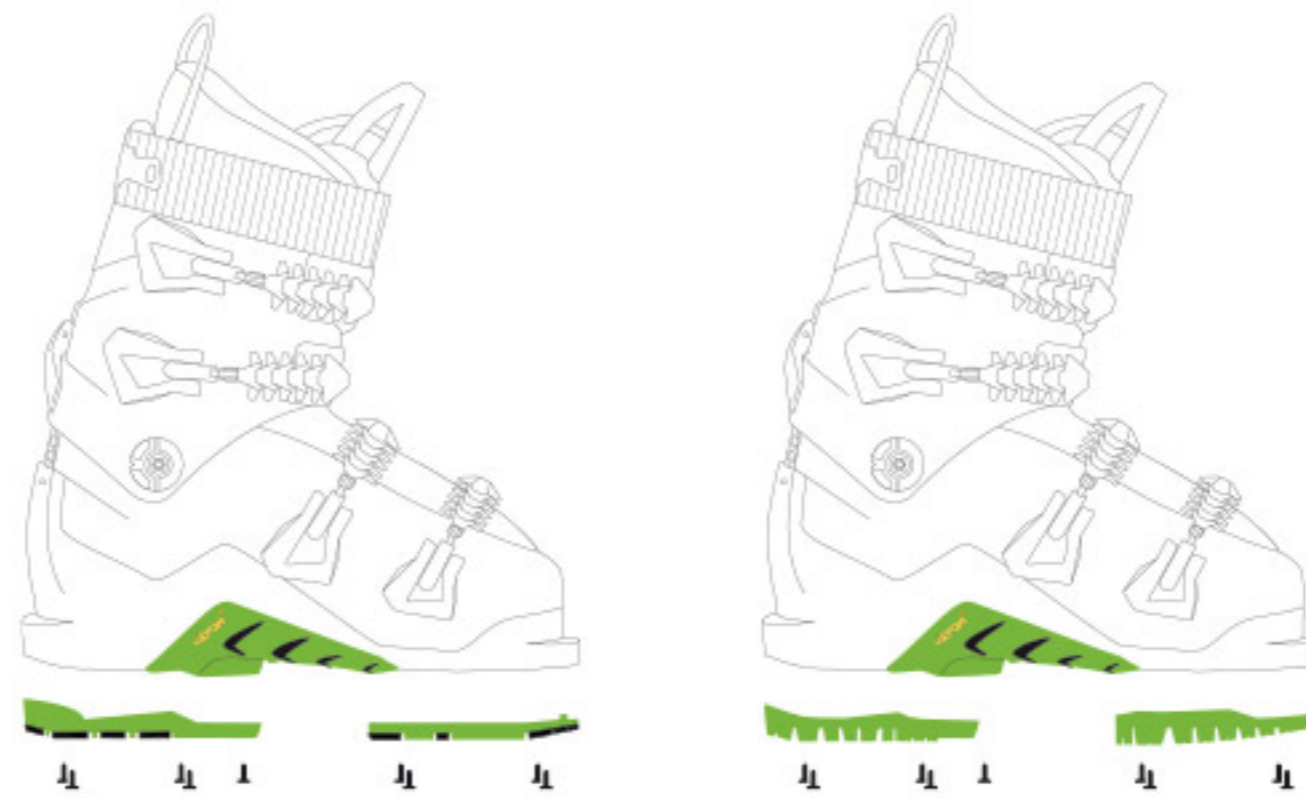

BOOT TECHNOLOGY / OVERKILL, OBLIVION, VENTURE, THE SHOW

SHOCK ABSORPTION WEDGE

A rubberized boot board that allows for smoother riding over varied terrain as well as an additional layer of protection from impact to create a shock-free landing.

BOOT TECHNOLOGY / THE SHOW

P&P – HIGHER LINER

High Profile P&P liner to grant the best support and comfort when landing.

BOOT TECHNOLOGY / DREAM



Women's performance last

Narrower heel width and forefoot dimension, smaller ankle circumference to perfectly fit female morphology.

Shell insert

Easy-entry thanks to soft overinjected insert and PU overlapping plate.



Double adjustable profile

New designed rear spoiler able to increase by 1cm the calf circumference by rotating the 2 screw hidden under the rear part of the velcro. With a low cuff no calf will pinch anymore.



Double tongue liner

Permits the woman's calf to widen freely backwards and find a comfortable accommodation in the space obtained through the movement of the rear spoiler.

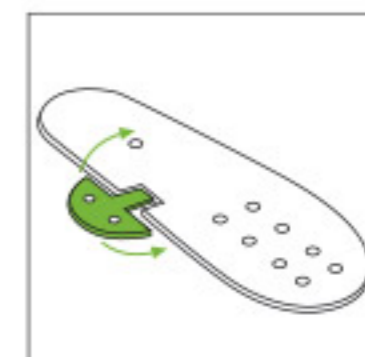

Adjustable Wedge Arch

Equipped with «on-off» mechanism for custom adjustment of the wedge arch. Customization of the arch support is then possible corresponding to different skier's feet by rotating the flap on or off the upper surface of the wedge.





RAPTOR B2 RD

ART.N°: 603002

FEATURES

Flex stance performance tuning • Double canting
• Rear support tuning • Racing spoiler • RD slalom
kit • FIS approved sole thickness

LINER

Racing Pro liner • Adjustable tongue • Lacing option
• Racing footbed • 40 mm Double Power Booster
velcro strap

BUCKLES

• 4 screwed micro-adjustable Spineflex racing dpt
alloy buckles

LEVEL

Athlete

SIZES

235-245-...-285

LAST

RD 1500cc

LAST	91	93	95
SIZE	25,5	26,5	27,5

COLOR

White

FLEX INDEX

160/150/140

SHELL

PU



RAPTOR B3 RD

ART.N°: 603004

FEATURES

Flex stance performance tuning
• Double canting • Rear support
tuning • Racing spoiler • RD slalom
kit • FIS approved sole thickness

LINER

• Racing Pro liner • Adjustable
tongue • Lacing option • Racing
footbed • 40 mm Double Power
Booster velcro strap

BUCKLES

• 4 screwed micro-adjustable
Spineflex racing dpt alloy buckles

LEVEL

Athlete

FLEX INDEX

140/130/120

SIZES

235-245-...-285

SHELL

PU

LAST

RD 1500cc

LAST	91	93	95
SIZE	25,5	26,5	27,5

COLOR

White



RAPTOR 130 RS
ART.N°: 603007

- FEATURES**
Flex stance performance tuning
• Double canting • Rear support tuning • FIS approved sole thickness
• Low racing wedge
- LINER**
• Performance Pro liner • HP frame footbed
Booster velcro strap

- BUCKLES**
• 4 micro-adjustable Spineflex racing alloy buckles
- LEVEL**
Professional
- FLEX INDEX**
140/130/120
- SIZES**
230-235-240-...-295-305
- SHELL**
PU
- LAST**
RS 1800cc
- | | | | |
|------|------|------|------|
| LAST | 94 | 96 | 98 |
| SIZE | 25.5 | 26.5 | 27.5 |
- COLOR**
White

RAPTOR 115 RS
ART.N°: 603010

- FEATURES**
Racing flex tuning • Double canting • FIS approved sole thickness • Low racing wedge
- LINER**
HeatFit Pro liner • HP frame footbed
• 40 mm velcro strap
- BUCKLES**
• 4 micro-adjustable Spine-Tech alloy buckles
- LEVEL**
Professional
- FLEX INDEX**
115/105
- SIZES**
230-235-240-...-295-305
- SHELL**
PU
- LAST**
RS 1800cc
- | | | | |
|------|------|------|------|
| LAST | 94 | 96 | 98 |
| SIZE | 25.5 | 26.5 | 27.5 |
- COLOR**
White



TUNING KIT RACING

ART.N°: 60117427



INNERBOOT FOAM PRO

ART.N°: 60115746



HEEL / TOE LIFTERS 3MM

ART.N°: 60115023

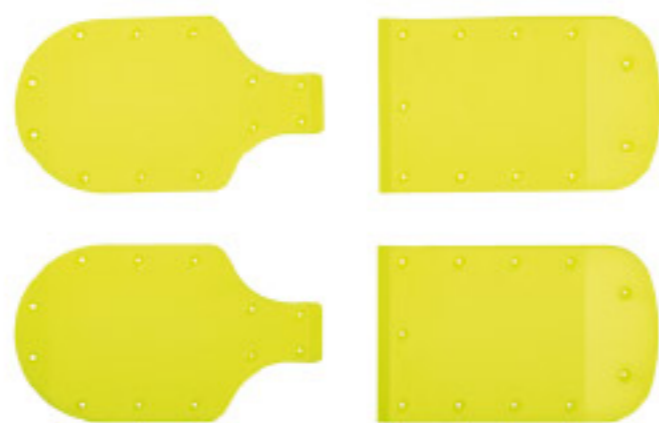

HEEL / TOE LIFTERS 5MM

ART.N°: 60115024

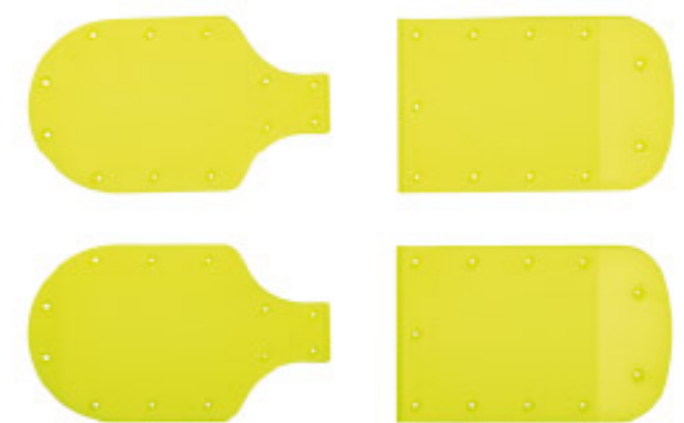

KIT SPOILER REAR CUFF

ART.N°: 60113605

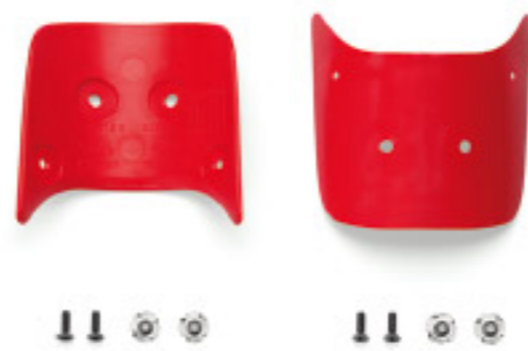

KIT SL RACING

ART.N°: 60115754







CHALLENGER 130

ART.N°: 604025

FEATURES

Bi-Inj. frame • Adaptive fit technology
• Ski-hike mechanism • Easy entry shell design • Rear support tuning

LINER

Perfect Fit Pro liner • HP frame footbed • 40 mm velcro strap • 40 mm Double Power Booster velcro strap

BUCKLES

4 micro-adjustable Spineflex alloy buckles • 2 Double Power levers
• 1 Supermacro ratchet

LEVEL

Professional

FLEX INDEX

130

SIZES

240-245-...-305

LAST

S 2000cc

LAST SIZE	97-99	99-101	101-103
SIZE	25.5	26.5	27.5

SHELL

PU

COLOR

Trsp. Yellow/Black

CHALLENGER 120

ART.N°: 604027 TRSP. ANTRACITE/BLACK
ART.N°: 604028 TRSP. GREEN/BLACK

FEATURES

Bi-Ing. energy frame • Adaptive fit technology • Ski-hike mechanism
• Easy entry shell design • Rear support tuning

LINER

Perfect Fit HP liner • HP frame footbed • 40 mm velcro strap

BUCKLES

4 micro-adjustable Spine-Tech alloy buckles • 2 Double Power levers
• 1 Supermacro ratchet

LEVEL

Professional

SIZES

250-255-...-305

LAST

S 2000cc

LAST SIZE	97-99	99-101	101-103
SIZE	25.5	26.5	27.5

FLEX INDEX

120

SHELL

PU

COLORS

Trsp. Antracite/Black
Trsp. Green/Black



CHALLENGER 110

ART.N°: 604037

FEATURES

Bi-Inj. frame • Adaptive fit technology
• Ski-hike mechanism • Easy entry shell design • Rear support tuning

LINER

Perfect Fit S liner • HP frame footbed
• 40 mm velcro strap

BUCKLES

4 micro-adjustable Spine-Tech alloy buckles • 1 Supermacro ratchet

LEVEL

Expert

FLEX INDEX

110

SIZES

240-245-250-255-...-305

SHELL

PU/SL

LAST

S 2000cc

LAST SIZE	97-99	99-101	101-103
SIZE	25.5	26.5	27.5

COLOR

Trsp. Red/Black





VECTOR 125

ART.N°: 604040

FEATURES

Tri-Inj. frame • Easy entry shell design • Flex stance tuning • Double canting • Rear support tuning

LINER

Perfect Fit HP liner • HP frame footbed • 40 mm velcro strap

BUCKLES

4 micro-adjustable Spineflex alloy buckles • 2 Double Power levers

• 1 Supermacro ratchet

LEVEL

Professional

FLEX INDEX

125/115

SIZES

250-255-...-305

SHELL

PU

LAST

S 2000cc

LAST	99	101	103
SIZE	25.5	26.5	27.5

COLOR

Trsp. Anthracite/Black

VECTOR 115

ART.N°: 604045

FEATURES

Tri-Inj. frame • Easy entry shell design • Flex stance tuning • Double canting • Rear support tuning

LINER

Perfect Fit HP liner • HP frame footbed • 40 mm velcro strap

BUCKLES

4 micro-adjustable Spine-Tech alloy buckles • 2 Double Power levers

• 1 Supermacro ratchet

LEVEL

Expert

FLEX INDEX

115/105

SIZES

250-255-...-305

SHELL

PU

LAST

S 2000cc

LAST	99	101	103
SIZE	25.5	26.5	27.5

COLOR

White/Black-Yellow



VECTOR 105

ART.N°: 604055

FEATURES

Tri-Inj. frame • Easy entry shell design • Flex tuning • Double canting • Rear support tuning

LINER

Perfect Fit S liner • HP frame footbed • 40 mm velcro strap

BUCKLES

4 micro-adjustable Spine-Tech alloy buckles • 1 Supermacro ratchet

LEVEL

Expert

FLEX INDEX

105/95

SIZES

250-255-...-305

SHELL

PU/SL

LAST

S 2000cc

LAST	99	101	103
SIZE	25.5	26.5	27.5

COLOR

White/Red/Trsp. Black





ADAPT EDGE 110

ART.N°: 604106

FEATURES

Tri-Inj. energy frame • Adaptive fit technology • Easy entry shell design
• Stiffer/softer flex adjustment
• Double canting • Adjustable rear spoiler • SoftWalk heel + grip system

LINER

Perfect Fit HP liner • Sport frame footbed • 40 mm velcro strap

BUCKLES

4 micro-adjustable Spine-Tech alloy buckles • 2 Double Power levers
• 1 Supermacro ratchet

LEVEL

Advanced

FLEX INDEX

110/100

SIZES

250-255-260-265...-305

SHELL

PU

LAST

C 2100cc

LAST	100-98	102-100	104-102
SIZE	25.5	26.5	27.5

COLOR

Trsp. Anthracite/Black

ADAPT EDGE 100

ART.N°: 604109 TRSP. RED/BLACK
ART.N°: 604112 TRSP. BLUE/BLACK

FEATURES

Tri-Inj. energy frame • Adaptive fit technology • Easy entry shell design
• Stiffer/softer flex adjustment
• Double canting • Adjustable rear spoiler • SoftWalk heel + grip system

LINER

Perfect Fit HP liner • Sport frame footbed • 40 mm velcro strap

BUCKLES

4 micro-adjustable Spine-Tech alloy buckles • 2 Double Power levers
• 1 Supermacro ratchet

LEVEL

Advanced

FLEX INDEX

100/90

SIZES

250-255...-305 (Blue)

250-255-260-265...-205-310-320-330-340 (Red)

SHELL

PU/SL

LAST

C 2100cc

LAST	100-98	102-100	104-102
SIZE	25.5	26.5	27.5

COLORS

Trsp. Red/Black

Trsp. Blue/Black



ADAPT EDGE 90

ART.N°: 604135 TRSP. ANTHRACITE/BLACK/YELLOW
ART.N°: 604136 TRSP./BLACK/GREEN

FEATURES

Tri-Inj. energy frame • Adaptive fit technology • Easy entry shell design
• Stiffer/softer flex adjustment
• Double canting • Adjustable rear spoiler • SoftWalk heel + grip system

LINER

Perfect Fit HP liner • Sport frame footbed • 40 mm velcro strap

BUCKLES

• 4 micro-adjustable alloy buckles
• 2 Double Power levers
• 1 Supermacro ratchet

LEVEL

Advanced

FLEX INDEX

90/80

SIZES

250-255-260-265...-305

SHELL

SL

LAST

C 2100cc

LAST	100-98	102-100	104-102
SIZE	25.5	26.5	27.5

COLORS

Trsp. Anthracite/Black/Yellow

Trsp./Black/Green





NEXT EDGE 80

ART.N°: 604160

FEATURES

- Tri-Inj. energy frame
- Easy entry shell design
- Double canting
- SoftWalk heel

LINER

- HeatFit liner
- Sport frame footbed
- 40 mm velcro strap

BUCKLES

- 4 micro-adjustable alloy buckles
- 1 Supermacro ratchet

LEVEL

Advanced

FLEX INDEX

80

SIZES

250-255-260-265-...-305

SHELL

SL

LAST

C 2100CC

LAST	100	102	104
SIZE	25,5	26,5	27,5

COLOR

White/Black

NEXT EDGE 70

ART.N°: 604205 BLACK/ANTHRACITE
ART.N°: 604206 WHITE/BLACK

FEATURES

Tri-Inj. energy frame • Easy entry shell design
• Double canting • SoftWalk heel

LINER

Comfort liner • Sport frame footbed

- 40 mm velcro strap

BUCKLES

- 4 micro-adjustable plastic buckles
- 1 Supermacro ratchet

LEVEL

Intermediate

FLEX INDEX

70

SIZES

250-255-260-265-...-305

SHELL

SL

LAST

C 2100CC

LAST	100	102	104
SIZE	25,5	26,5	27,5

COLORS

Black/Anthracite

White/Black





CUBE 3 12

ART.N°: 604307

FEATURES

Bi-Inj power control frame
• Integrated autoskiwalk • Softwalk heel + gripSystem

LINER

SuperHeat3 quick entry liner • Sport frame footbed • 35 mm velcro strap

BUCKLES

2 micro-adjustable alloy buckles
• 1 micro-adjustable wide-body alloy buckles • 1 Supermacro ratchet

LEVEL

Advanced

FLEX INDEX

90

SIZES

250-255-260-265-...-305

SHELL

PU/SL

LAST

EC 2200cc

LAST	102	104	106
SIZE	25.5	26.5	27.5

COLOR

Trsp. Anthracite/Black

CUBE 3 10

ART.N°: 604325

FEATURES

Bi-Inj power control frame
• Integrated autoskiwalk • Softwalk heel + gripSystem

LINER

HeatFit quick entry liner • Sport frame footbed • 35 mm velcro strap

BUCKLES

2 micro-adjustable alloy buckles
• 1 micro-adjustable wide-body alloy buckles • 1 Supermacro ratchet

LEVEL

Intermediate

FLEX INDEX

80

SIZES

250-255-260-265-...-305

SHELL

SL

LAST

EC 2200cc

LAST	102	104	106
SIZE	25.5	26.5	27.5

COLOR

Trsp. Anthracite/Black/Green



CUBE 3 8

ART.N°: 604350

FEATURES

• Power control frame
• Integrated autoskiwalk

LINER

Comfort quick entry liner • Sport frame footbed • 35 mm velcro strap

BUCKLES

2 micro-adjustable plastic buckles
• 1 micro-adjustable wide-body alloy buckles • 1 Supermacro ratchet

LEVEL

Intermediate

FLEX INDEX

70

SIZES

250-255-260-265-...-320

SHELL

SL

LAST

EC 2200cc

LAST	102	104	106
SIZE	25.5	26.5	27.5

COLOR

Black





RAPTOR OVERKILL

ART.N°: 604008

FEATURES

Vibram sole • Racing flex stance-tuning • Rubber inserts • Double canting • Shock absorbing wedge

LINER

HeatFit Pro liner • HP frame and shock-absorber footbed • 50 mm velcro strap

BUCKLES

• 4 micro-adjustable Spine-Tech alloy buckles

LEVEL

Professional

FLEX INDEX

140/130/120

SIZES

260-265-...-290-295

SHELL

PU

LAST

RS 1800cc

LAST	96	98
SIZE	26,5	27,5

COLOR

Black

VENTURE ATX

ART.N°: 604014

FEATURES

Vibram sole • Bi-Inj. frame • Ski-tour mechanism • Lacing option • Touring sole option • Shock absorbing wedge

LINER

- Intuition Dreamliner
- HP frame footbed
- 40 mm velcro strap

BUCKLES

- 4 micro-adjustable alloy buckles
- 1 Supermacro ratchet

LEVEL

Professional

FLEX INDEX

110

SIZES

250-255-...-305

SHELL

GRILFLEX/SL

LAST

FR 1900cc

LAST	96	98	100
SIZE	25,5	26,5	27,5

COLOR

White/Light-Blue/Yellow



VENTURE 130

ART.N°: 604015

FEATURES

Bi-Inj. frame • Vibram sole • Skitour mechanism • Lacing option • Touring sole option • Shock absorbing wedge

LINER

Perfect Fit Pro S liner • HP frame footbed • 40 mm velcro strap

BUCKLES

• 4 micro-adjustable Spine-Tech alloy buckles • 1 Supermacro ratchet

LEVEL

Professional

FLEX INDEX

130

SIZES

250-255-...-305

SHELL

PU

LAST

FR 1900cc

LAST	96	98	100
SIZE	25,5	26,5	27,5

COLOR

White/Black





RAPTOR OBLIVION

ART.N°: 604009

FEATURES

Racing flex stancetuning • Double canting • Shock absorbing wedge

LINER

• HeatFit Pro liner • HP frame and shock-absorber footbed • 50 mm velcro strap

BUCKLES

• 4 micro-adjustable Spine-Tech alloy buckles

LEVEL

Professional

FLEX INDEX

140/130/120

SIZES

260-265-...-290-295

SHELL

PU

LAST

RS 1800cc

LAST	96	98
SIZE	26.5	27.5

COLOR

Black

THE SHOW 1

ART.N°: 603401

FEATURES

Bi-Inj power control frame
• Softwalk heel + gripsystem
• Double rivet cuff • Shock absorbing wedge • Higer liner

LINER

• HeatFit liner • Sport frame and shock-absorber footbed • 50 mm velcro strap • High Profile liner

BUCKLES

2 micro-adjustable alloy buckles
• 1 micro-adjustable wide-body alloy buckle • 1 Supermacro ratchet

LEVEL

Advanced 100

SIZES

250-260-265-...-305

LAST

EC 2200cc

LAST	102	104	106
SIZE	25.5	26.5	27.5

COLOR

White

FLEX INDEX

100

SHELL

PU/SL



THE SHOW 2

ART.N°: 604402

FEATURES

• Bi-Inj power control frame
• Softwalk heel + gripsystem
• Shock absorbing wedge

LINER

HeatFit liner • Sport frame and shock-absorber footbed • 50 mm velcro strap

BUCKLES

2 micro-adjustable alloy buckles
• 1 micro-adjustable wide-body alloy buckle • 1 Supermacro ratchet

LEVEL

Advanced

FLEX INDEX

90

SIZES

250-255-260-265-...-305

SHELL

SL

LAST

EC 2200cc

LAST	102	104	106
SIZE	25.5	26.5	27.5

COLOR

Black





RAPTOR 110 RS W

ART.N°: 604012

FEATURES

- Racing flex tuning
- Double canting
- FIS approved sole thickness

LINER

- Women's HeatFit Pro liner
- HP frame footbed
- 40 mm velcro strap

BUCKLES

- 4 micro-adjustable Spine-Tech alloy buckles

LEVEL

Professional

FLEX INDEX

110/100

SIZES

220-225-230-...-275

SHELL

PU

LAST

RS 1800cc

LAST	94	96	98
SIZE	25.5	26.5	27.5

COLOR

Black

CHALLENGER 110 W

ART.N°: 604038

FEATURES

Bi-Inj. frame • Adaptive fit technology • Ski-hike mechanism • Easy entry shell design • Rear support tuning

LINER

- Women's Perfect Fit S liner
- HP frame footbed
- 40 mm velcro strap

BUCKLES

4 micro-adjustable Spine-Tech alloy buckles • 1 Supermacro ratchet

LEVEL

Expert

FLEX INDEX

100

SIZES

230-235-...-270-275

SHELL

PU/SL

LAST

S 2000cc

LAST	97-99	99-101	101-103
SIZE	25.5	26.5	27.5

COLOR

Trsp. Anthracite/Black



VECTOR 105 W

ART.N°: 604056

FEATURES

Bi-Inj. frame • Easy entry shell design • Double canting • Flex tuning • Woman specific supportive heel option

LINER

Women's Perfect Fit S liner • 40 mm velcro strap • HP frame footbed

BUCKLES

4 micro-adjustable Spine-Tech alloy buckles • 1 Supermacro ratchet

LEVEL

Expert

FLEX INDEX

95/85

SIZES

230-235-...-275

SHELL

PU/SL

LAST

S 2000cc

LAST	99	101	103
SIZE	25.5	26.5	27.5

COLOR

Trsp./Silver/White





DREAM 100 W

ART.N°: 604510

FEATURES

Stiffer/softer flex adjustment
 • Adjustable wedge arch support
 • Double canting • Double adjustable profile • Softwalk heel + grip system • Woman-specific supportive heel option

LINER

Women's Perfect Fit HP liner • Fur lining • Self-shaping footbed with Sanitized® • 30 mm velcro strap
 • Prepared for heating system

BUCKLES

4 micro-adjustable Spine-Tech magnesium buckles • 2 Double Power levers • 1 Supermacro ratchet • Easy Entry instep ratchet

LEVEL FLEX INDEX

Professional 100/90

SIZES SHELL

220-225-230-...-275 PU

LAST

WP 1950cc

LAST	98	100	102
SIZE	25.5	26.5	27.5

COLOR

Light-Blue/White

DREAM 90 W

ART.N°: 604520

FEATURES

Stiffer/softer flex adjustment
 • Adjustable wedge arch support
 • Double canting • Double adjustable profile • Softwalk heel • Woman-specific supportive heel option

LINER

Women's Perfect Fit HP liner
 • Fur lining • Self-shaping footbed with Sanitized® • 30 mm velcro strap • Prepared for heating system

BUCKLES

4 micro-adjustable Spine-Tech magnesium buckles • 2 Double Power levers • 1 Supermacro ratchet
 • Easy Entry instep ratchet

LEVEL FLEX INDEX

Expert 90/80

SIZES SHELL

220-225-230-...-275 SL

LAST

WP 1950cc

LAST	98	100	102
SIZE	25.5	26.5	27.5

COLOR

Light-Blue/White



DREAM 80 W

ART.N°: 604525

FEATURES

Adjustable wedge arch support
 • Double canting • Double adjustable profile • Softwalk heel • Woman-specific supportive heel option

LINER

Women's Perfect Fit HP liner
 • Fur lining • Self-shaping footbed with Sanitized® • 30 mm velcro strap • Prepared for heating system

BUCKLES

4 micro-adjustable Spine-Tech magnesium buckles • 1 Supermacro ratchet • Easy Entry instep ratchet

LEVEL FLEX INDEX

Advanced 80

SIZES SHELL

220-225-230-...-275 SL

LAST

WP 1950cc

LAST	98	100	102
SIZE	25.5	26.5	27.5

COLOR

Black



ADAPT EDGE 100 W

ART.N°: 604114

FEATURES

Tri-Inj. energy frame • Adaptive fit technology
• Easy entry shell design • Stiffer/softer flex adjustment • Double canting • Adjustable rear spoiler • Softwalk heel + grip system

LINER

Women's Perfect Fit HP liner • Fleece lining
• Sport frame footbed • 30 mm velcro strap

BUCKLES

4 micro-adjustable Spine-Tech alloy buckles
• 2 Double Power levers • 1 Supermacro ratchet

LEVEL

Advanced

FLEX INDEX

90/80

SIZES

220-225-230-235-...-275

SHELL

PU/SL

LAST

C 2100cc

LAST	100-98	102-100	104-102
SIZE	25,5	26,5	27,5

COLOR

Trsp./Silver/White



ADAPT EDGE 90 W

ART.N°: 604138 TRSP./WHITE
ART.N°: 604139 TRSP. ANTHRACITE/BLACK

FEATURES

Tri-Inj. energy frame • Adaptive fit technology • Easy entry shell design • Stiffer/softer flex adjustment • Double canting
• Adjustable rear spoiler • Softwalk heel + grip system

LINER

Women's Perfect Fit HP liner • Fleece lining • Sport frame footbed • 30 mm velcro strap • prepared for heating system

BUCKLES

4 micro-adjustable alloy buckles • 2 Double Power levers
• 1 Supermacro ratchet

LEVEL

Advanced

FLEX INDEX

80/70

SIZES

220-225-230-235-...-275

SHELL

SL

LAST

C 2100cc

LAST	100-98	102-100	104-102
SIZE	25,5	26,5	27,5

COLORS

Trsp./White

Trsp. Anthracite/Black





NEXT EDGE 80 W

ART.N°: 604161

FEATURES

- Tri-Inj. energy frame
- Easy entry shell design
- Double canting
- Softwalk heel

LINER

- Women's HeatFit liner
- Fleece lining
- Sport frame footbed
- 30 mm velcro strap
- prepared for heating system

BUCKLES

- 4 micro-adjustable alloy buckles
- 1 Supermacro ratchet

LEVEL

Advanced

FLEX INDEX

70

SIZES

220-225-230-235-...-275

SHELL

SL

LAST

C 2100cc

LAST	100	102	104
SIZE	25,5	26,5	27,5

COLOR

White/Silver

NEXT EDGE 70 W

ART.N°: 604207 WHITE/SILVER
ART.N°: 604208 BLACK/ANTHRACITE

FEATURES

Tri-Inj. energy frame • Easy entry shell design
• Double canting • Softwalk heel

LINER

Comfort liner • Fleece lining • Sport frame
footbed • 30 mm velcro strap

BUCKLES

- 4 micro-adjustable plastic buckles
- 1 Supermacro ratchet

LEVEL

Intermediate

FLEX INDEX

60

SIZES

220-225-230-235-...-275

SHELL

SL

LAST

C 2100cc

LAST	100	102	104
SIZE	25,5	26,5	27,5

COLORS

White/Silver

Black/Anthracite





CUBE3 12 W

ART.N°: 604008

FEATURES

Bi-Inj • power control frame
• Integrated autoskiwalk • Softwalk heel + gripsystem

LINER

Women's SuperHeat 3 quick entry liner • Sport frame footbed
• 35 mm velcrostrap

BUCKLES

• 2 micro-adjustable alloy buckles
• 1 micro-adjustable wide-body alloy buckles • 1 Supermacro ratchet

LEVEL

Advanced

FLEX INDEX

80

SIZES

230-235-...-275

SHELL

PU/SL

LAST

EC 2200cc

LAST	102	104	106
SIZE	25,5	26,5	27,5

COLOR

Trsp./White

CUBE3 10 W

ART.N°: 604326

FEATURES

Bi-Inj • power control frame
• Integrated autoskiwalk • Softwalk heel + gripsystem

LINER

Women's HeatFit quick entry liner
• Sport frame footbed • 35 mm velcrostrap

BUCKLES

• 2 micro-adjustable alloy buckles
• 1 micro-adjustable wide-body alloy buckles • 1 Supermacro ratchet

LEVEL

Intermediate

FLEX INDEX

70

SIZES

230-235-...-275

SHELL

SL

LAST

EC 2200cc

LAST	102	104	106
SIZE	25,5	26,5	27,5

COLOR

Trsp./White



CUBE3 8 W

ART.N°: 604351 WHITE

ART.N°: 604352 BLACK

FEATURES

• Power control frame
• Integrated autoskiwalk

LINER

• Women's Comfort quick entry liner
• Sport frame footbed
• 35 mm velcro strap

BUCKLES

2 micro-adjustable plastic buckles
• 1 micro-adjustable wide-body alloy buckles • 1 Supermacro ratchet

LEVEL

Intermediate

FLEX INDEX

60

SIZES

230-235-...-275

SHELL

SL

LAST

EC 2200cc

LAST	102	104	106
SIZE	25,5	26,5	27,5

COLORS

White

Black





RAPTOR B5 RD

ART.N°: 603600

FEATURES

Jr racing flex tuning • Jr Cuff
• Double canting • FIS approved sole thickness • Adult norm

LINER

• Jr HeatFit Pro liner
• HP frame footbed
• 40 mm velcro strap

BUCKLES

• 4 micro-adjustable Spine-Tech alloy buckles

LEVEL

Professional

FLEX INDEX

110/100

SIZES

220-225-...-285

SHELL

PU

LAST

RD 1500cc

LAST	91	93	95
SIZE	25.5	26.5	27.5

COLOR

White

RAPTOR 90 RS

ART.N°: 603610

FEATURES

Jr racing flex tuning • Jr cuff
• Double canting • FIS approved sole thickness • Adult norm

LINER

• Jr HeatFit Pro liner
• HP frame footbed
• 40 mm velcro strap

BUCKLES

• 4 micro-adjustable Spine-Tech alloy buckles

LEVEL

Professional

FLEX INDEX

90/80

SIZES

220-225-...-275-280-285

SHELL

PU

LAST

RS 1800cc

LAST	94	96	98
SIZE	25.5	26.5	27.5

COLOR

White



RAPTOR 80 RS

ART.N°: 604611

FEATURES

Jr racing flex tuning • Jr Cuff
• Double canting • FIS approved sole thickness • Adult norm

LINER

• Jr HeatFit Pro liner
• HP frame footbed
• 40 mm velcro strap

BUCKLES

• 4 micro-adjustable Spine-Tech alloy buckles

LEVEL

Expert

FLEX INDEX

80/70

SIZES

220-225-...-275-280-285

SHELL

PU

LAST

RS 1800cc

LAST	94	96	98
SIZE	25.5	26.5	27.5

COLOR

White



RAPTOR 70

ART.N°: 603615

FEATURES

- Jr racing flex tuning
- Adult norm (size 220 up)

LINER

- Junior team liner
- Self-shaping footbed
- 30 mm velcro strap

BUCKLES

- 4 micro-adjustable Spine-Tech alloy buckles

LEVEL

Expert

FLEX INDEX

70/60

SIZES

200-210-220-...-275

SHELL

SL

LAST

JR Racing

LAST	91	93	95
SIZE	25,5	26,5	27,5

COLOR

White



RAPTOR 50

ART.N°: 604621

FEATURES

- Jr racing flex tuning
- Adult norm (size 220 up)

LINER

- Junior team liner
- Self-shaping footbed
- 30 mm velcro strap

BUCKLES

- 4 plastic buckles

LEVEL

Advanced

FLEX INDEX

50

SIZES

200-210-220-...-275

SHELL

SL

LAST

JR Racing

COLOR

White

RAPTOR 40

ART.N°: 604631

FEATURES

- Jr racing flex tuning
- Adult norm (size 220 up)

LINER

- Junior team liner
- Self-shaping footbed

BUCKLES

- 3 plastic buckles

LEVEL

Advanced

FLEX INDEX

40

SIZES

185-190-...-245

SHELL

SL

LAST

JR Racing

COLOR

White





RAPTOR CADDY 50 JR

ART.N°: 604620

FEATURES	BUCKLES	SHELL
Jr racing flex tuning	• 4 plastic buckles	SL
• Adult norm (size 220 up)	LEVELS	LAST
LINER	Advanced	JR Racing
• Junior team liner	FLEX INDEX	COLOR
• Self-shaping footbed	60	Black/White
• 40 mm velcro strap	SIZES	
	200-210-220-...-275	

RAPTOR CADDY 40 JR

ART.N°: 604630

FEATURES	LEVEL	LAST
Jr racing flex tuning	Advanced	JR Racing
• Adult norm (size 220 up)	FLEX INDEX	COLOR
LINER	50	Black/White
• Junior team liner	SIZES	
• Self-shaping footbed	185-190-...-245	
BUCKLES	SHELL	
• 3 plastic buckles	SL	



SOUP HEAD 2

ART.N°: 603671

FEATURES	BUCKLES	LAST
Easy entry shell construction • Kids skiwalk	• 2 plastic buckles	Junior
• Junior norm • Design your boot stickers	LEVEL	COLOR
LINER	Beginner	White
• Junior liner	SIZES	
• Tongue handle	195-205-215-225	
• Comfort footbed	SHELL	
	SL	

SOUP HEAD 1

ART.N°: 603691

FEATURES	BUCKLES	LAST
Easy entry shell construction • Kids skiwalk	• 1 plastic buckle	Junior
• Junior norm • Design your boot stickers	LEVEL	COLOR
LINER	Beginner	White
• Junior liner	SIZES	
• Tongue handle	155-165-175-185	
• Comfort footbed	SHELL	
	SL	



EDGE J 3

ART.N°: 604645 BLACK/RED
 ART.N°: 604646 RED/WHITE
 ART.N°: 604647 WHITE/PINK

FEATURES

- Easy entry shell construction
- Softwalk heel
- Adult norm (230 up)

LINER

- Junior liner
- Tongue handle
- Comfort footbed

BUCKLES

- 3 plastic buckles

LEVEL

Intermediate

FLEX INDEX

230-235-...-265

SHELL

SL

LAST

JR Racing

COLORS

Black/Red
 Red/White
 White/Pink



EDGE J 2

ART.N°: 604655 BLACK/RED
 ART.N°: 604657 RED/WHITE
 ART.N°: 604658 WHITE/PINK

FEATURES

- Easy entry shell construction
- Kids skiwalk • Junior norm
- Design your boot stickers

LINER

- Junior liner
- Tongue handle
- Comfort footbed

BUCKLES

- 2 plastic buckles

LEVEL

Beginner

SIZES

195-205-215-225

SHELL

SL

LAST

JR Racing

COLORS

Black/Red
 Red/White
 White/Pink



EDGE J 1

ART.N°: 604675 BLACK/RED
 ART.N°: 604677 RED/WHITE
 ART.N°: 604678 WHITE/PINK

FEATURES

- Easy entry shell construction
- Kids skiwalk • Junior norm
- Design your boot stickers

LINER

- Junior liner
- Tongue handle
- Comfort footbed

BUCKLES

- 1 plastic buckle

LEVEL

Beginner

SIZES

155-165-175-185

SHELL

SL

LAST

JR Racing

COLORS

Black/Red
 Red/White
 White/Pink



Ambition

THE TOURING NEWCOMER

The TYROLIA AAmbition Alpine Touring binding is the perfect companion for all Alpine Touring Aficionados so that no terrain remains unattainable. We included every attribute of our high-performance alpine ski bindings in this Alpine Touring binding.

ALPINE TOURING TOE

This newcomer in the ski touring segment features the exclusive TYROLIA Alpine Touring (AT) Toe which can be easily adjusted to alpine and touring boot norms.

A 65 mm wide mechanical AFS gliding element secures constant release values also with rubber soles.

In combination with two rollers this binding provides superior safety features with the rapid and exact boot re-centering that skiers expect from TYROLIA.

As a result of its harmonious design, the TYROLIA AAmbition has a wider contact area which improves stability and provides a secure foundation for every skiing situation.

Furthermore, its pivot is efficiently positioned right below the ski boot tip to ensure perfect force transmission and a tilt up to 90 degrees.



EASY ADJUSTABLE TELESCOPIC TUBE

Additionally the AAmbition features a unique light-weight telescopic tube which offers an easy adjustment opportunity to different boot sole lengths. Thus, with only one binding model it is possible to cover the entire range of different sole lengths - from 260mm up to 350mm.

Furthermore, with the setting of the telescopic tube and through the compact mounting, perfect binding positioning on your skis is improved and mid-point deviation is avoided.



TYROLIA FREEFLEX

The TYROLIA approved Freeflex System, which interacts with the AT Toe, the telescopic tube and the AT Heel, offers natural dynamics, excellent downhill performance and therefore a supreme ski touring experience.

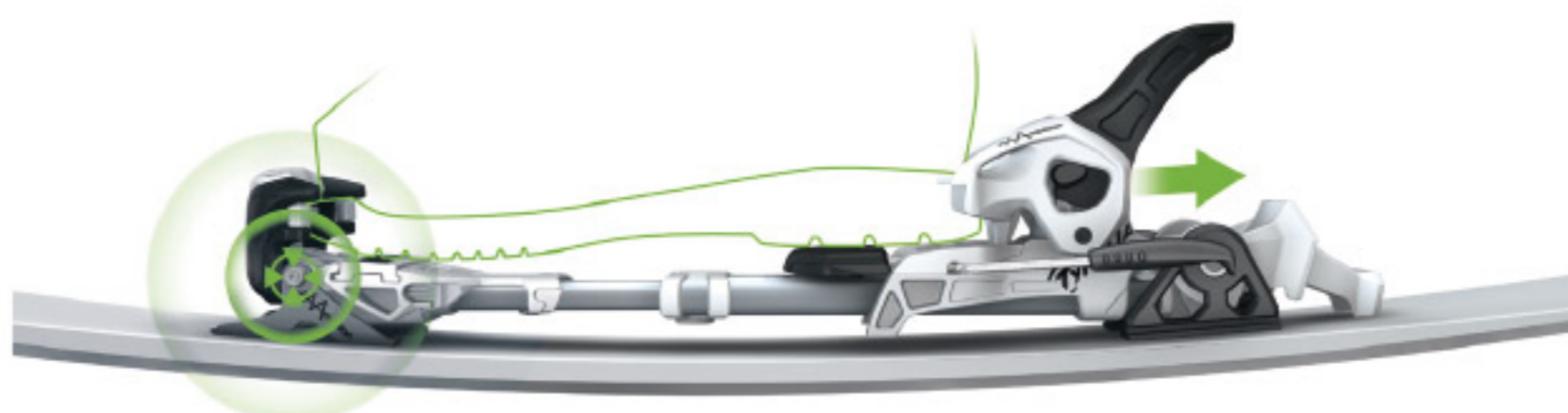



ALPINE TOURING HEEL AND CLIMBING AID

The state-of-the-art designed climbing aid is positioned as close as possible to the Alpine Touring (AT) Heel. This provides better walking balance and effortless climbing in all situations. The low stand height of 38 mm improves stability and offers a confident stance. With four different climbing aid positions (climbing in a 0°, 5°, 10° or 15° position) it is possible to adapt on different terrains without stepping out of the binding. It does not matter if it is a walk through flat terrain or a steep slope up to the summit. Simply use the ski pole in order to change the climbing aid position and also to lock for the downhill ride.

CRAMPONS

Additional crampons are available as spare parts in widths of 90 mm, 105 mm and 120 mm, and provide safe climbing and a secure stand in any situation.

- 90 mm: A. No.: 163006 (1 pair)
- 105 mm: A. No.: 163007 (1 pair)
- 120 mm: A. No.: 163008 (1 pair)

DEMO AND RENTAL SUITABLE

In order to offer ambitious sportsmen an opportunity to widen their horizons, the TYROLIA AAAmbition is also demo and rental suitable:

Combined with a spare demo track, the TYROLIA AAAmbition Alpine Touring binding can be tested and shown to a broad audience. Only two easy adjustments (one on the telescopic tube and one on the demo track) are required to fit to different boot lengths without extra drilling.



◀ 90mm ▶



BRAKES & INDIVIDUALITY

Considering the different ski widths, the TYROLIA AAAmbition comes without brakes. This gives you the opportunity to either choose the perfect fitting brake out of four different widths (85 mm/95 mm/105 mm/125 mm) or simply to ride and hike without brakes using appropriate powder straps – TYROLIA AAA-Series Powder Strap (1 pair): A. No.: 162981 Additionally available: TYROLIA AAA-Series Powdercord – A.No.: 163025

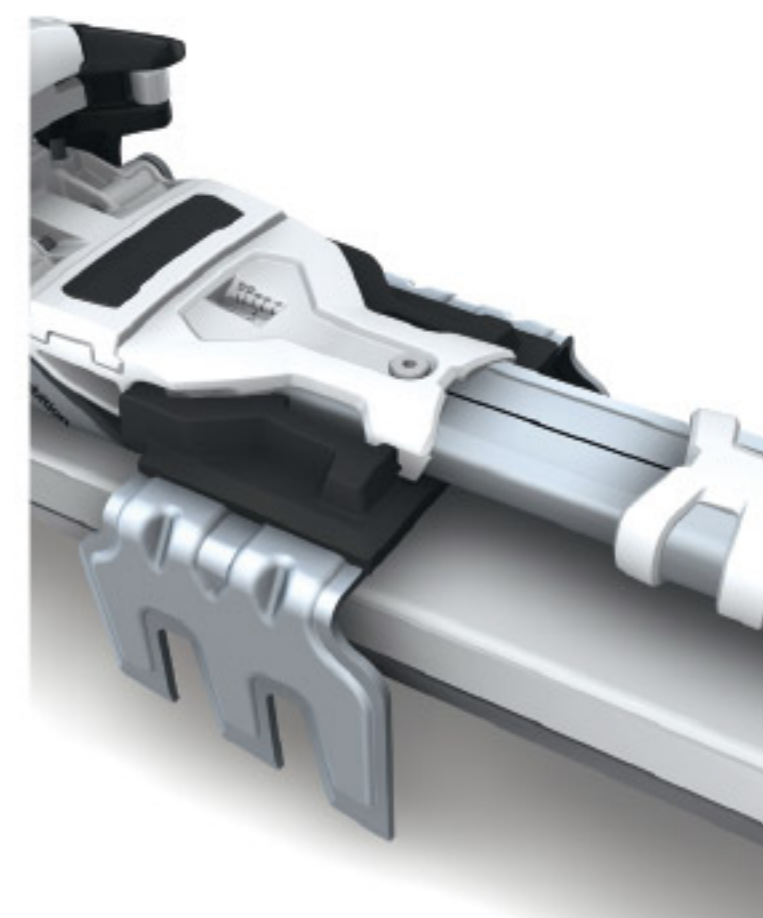

To sum up: The TYROLIA AAAmbition Alpine Touring binding is what every ski touring fanatic was looking for. On one hand it offers freedom and individual adjustment possibilities and on the other hand it provides the premium high-end performance that is expected from the world market leader TYROLIA. The solid, light-weight construction and its maximum functionality enhances the ultimate mountain experience for ambitious climbers as well as for touring newbies.

Overcome boundaries - Simply just: Access All Areas!

Adrenalin

THE PERFECT ALL-ROUNDER

With the AAAAdrenalin Freeride binding from TYROLIA, no terrain is out of reach. This binding provides a level of skiing performance never before seen in an alpine binding. It combines performance driven freeride features with the ultimate ergonomic walking mechanism for maximum freedom on-and off-piste. Overcome boundaries smoothly for a perfect ride.

The TYROLIA AAAAdrenalin binding is a perfect option for freeriders who prefer precise downhill control combined with ideal mechanics for short walks to reach untouched paths for a memorable ski experience. Designed together with freeskiers and backcountry skiers, this member of the TYROLIA AAA-Series is designed for ski widths from 80 mm and wider. The TYROLIA AAAAdrenalin brings paramount freeride performance in every terrain, on every slope.



FREERIDE (FR) PRO TOE

The TYROLIA AAAAdrenalin comes with the Freeride (FR) Pro Toe with its ergonomic pivot position for optimal tilt up movement up to 90 degrees. This system provides effortless walking over short distances.

The FR Pro Toe is adjustable by changing the position of the Anti-Friction-Slider (AFS Metal) to cover alpine and touring boot norms. This 68 mm wide slider plus a stainless steel gliding element provide constant release values and result in a broader contact area to the ski boot sole.

The benefits: more stability, more direct power transmission and an ultimate skiing performance.



FREERIDE (FR) PRO HEEL

The ultra-wide 80 mm heel track makes all the performance difference needed to take this product over the top. Extra width and the superior kinematics of TYROLIA's high performance bindings make it absolutely stable and reliable for perfect force transmission and unmatched performance. The heel can easily be adjusted to different boot sole lengths without any additional tools.

It covers a wide range of seven ski boot sizes. The TYROLIA AAAAdrenalin Freeride binding is available in two lengths:

- SHORT (S) for ski boot sole length of 270-330 mm
- LONG (L) for ski boot sole length of 300-360 mm



◀ 60mm ▶



AAA-ASCENDER LOCK AND CLIMBING AID

To Access All Areas, transition from skiing to hiking is incredibly fast, easy and convenient. Simply use the tip of the ski pole without stepping out of the binding to move the highly visible Ascender Lock to change between hiking and ski mode.

Another TYROLIA feature is the possibility to walk in the 0° position. After release, TYROLIA's climbing aid can easily be operated with a ski pole and it can be positioned in three different angles (0°, 7° and 13°) for an optimal walking position. This improves balance and a secure stand on your way to perfect skiing spots.

CRAMPONS

Additionally, TYROLIA crampons (available as spare parts in three widths: 90 mm, 105 mm and 120 mm) can be mounted to improve grip in steep and icy terrain.

- 90 mm: A. No.: 162977 (1 pair)
- 105 mm: A. No.: 162978 (1 pair)
- 120 mm: A. No.: 162979 (1 pair)



Whether skiing downhill or bridging walking paths, the TYROLIA AAAadrenalin Freeride binding gives adventures an unrivaled combination of skiing performance and all terrain versatility, providing easy Access to All Areas!

FREEFLEX

The platform of TYROLIA's AAAadrenalin binding provides the approved TYROLIA Freeflex function which allows the ski to flex as it is designed to do so it can retain its natural dynamics. Freeflex is enabled by the free gliding plate that runs within the titanal heel track and is supported by the center of rotation of the binding toe.



BRAKES & INDIVIDUALITY

The TYROLIA AAAadrenalin comes without brakes. This gives each freerider the chance to choose the precisely fitting brakes in regard to the ski widths. The TYROLIA AAAadrenalin bindings can be combined with brake widths of 88 mm, 97 mm, 115 mm or 130 mm.

Additionally available: TYROLIA AAA-Series Powdercord - Art. No.:163025

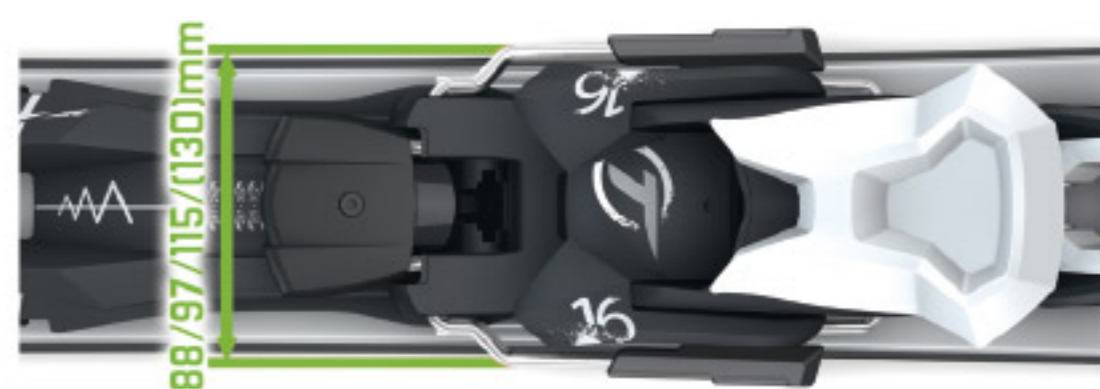

Attack

ASTONISHING PARK & PIPE ACTION

Freeskiers prefer equipment which provides control, performance and usability. Not only for clear slopes and untracked powder areas, also for stoked park and half pipe rides. The TYROLIA AAAAttack Freeski binding models combine functionality and modern design to meet these demands. A perfect tool for all-around skiers who are willing to attack!



MODERN ARCHITECTURE

The special Freeride (FR) Pro Toe with its horizontal spring reflects the modern architecture of the entire TYROLIA AAA-Series. Furthermore, it includes a super secure 77 mm metal anti friction device (AFD Metal), which can be adjusted for all types of alpine boots (Type A only).



The TYROLIA AAAAttack 16 features the Race Pro Heel, with a reduced stand height of only 17 mm for the ultimate freeski adventure. The TYROLIA AAAAttack 13 and AAAAttack 12 models feature a solid construction, reduced weight and a modified heel, which puts this model in a category of its own.

PERFECT INDIVIDUALITY

This fired up freeski binding models are available in three different DIN settings (TYROLIA AAAAttack 16, 13 and 12 – ideally suited for the brand new Women's Line). The built in AAA-Series technology ensures high quality and perfect usability. In regard to its clear design and its compact measurement, the AAAAttack model can be ideally used on ski widths from 80mm and wider. Some models are delivered without brakes.

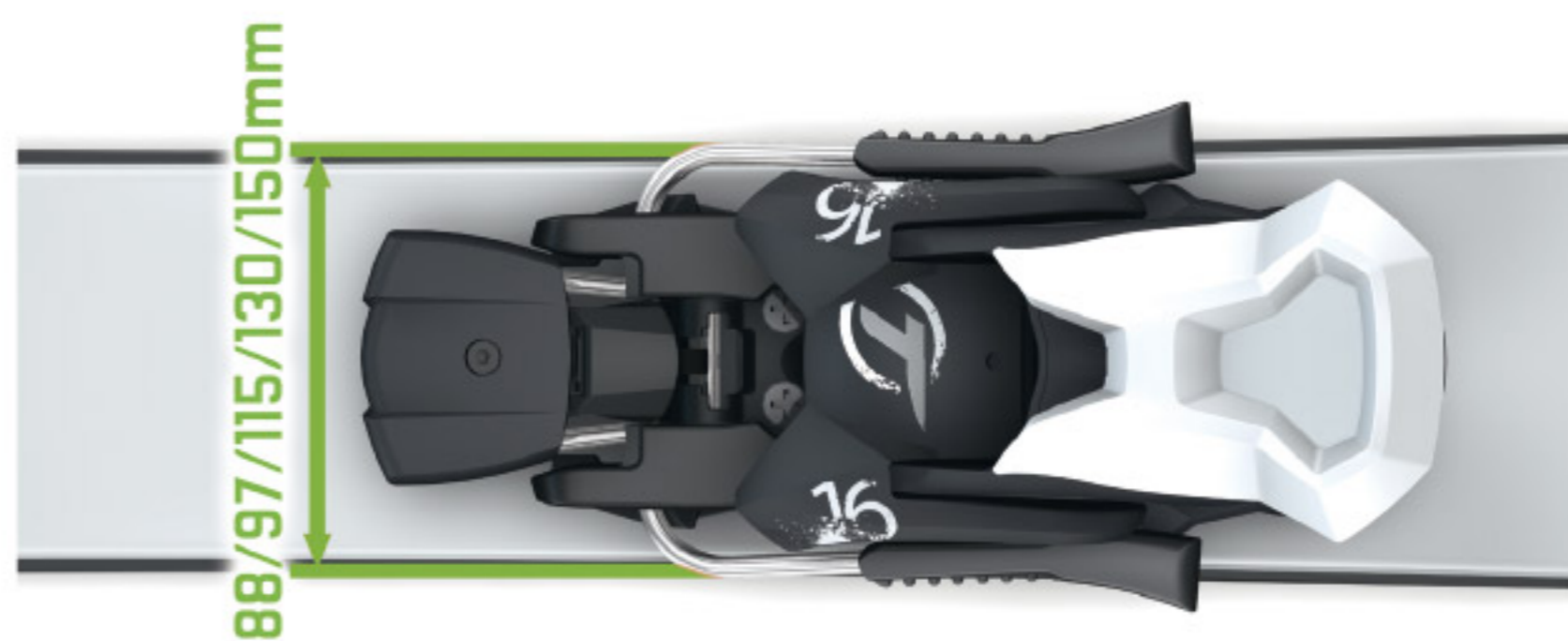

This gives riders the opportunity to customize the setup to their needs. Brakes are available in different widths: 88 mm, 97 mm, 115 mm, 130 mm and 150 mm. Additionally available: TYROLIA AAA-Series Powdercord – A.No.: 163025

Attack DEMO

TYROLIA AAATTACK 13 DEMO



NEWLY REDESIGNED

The TYROLIA AAAttack 13 DEMO model, a modified version of the TYROLIA AAAttack Freeski binding, is the first demo and rental suitable freeski binding that is anchored on a metal toe track. This unique feature ensures a lower stand height, a more compact design and increased stability compared with other bindings. In combination with the proven TYROLIA Rental Heel track, the TYROLIA AAAttack 13 DEMO offers the opportunity to fulfill every customer's desires, whether for retail, demo or rental purposes.

This easy to adapt TYROLIA AAAttack Freeski binding model was designed for a wide range of sole lengths, and therefore can be adjusted to all available alpine boot sole lengths from 259 to 386mm - tool-free in a matter of a few seconds, by moving the toe and heel pieces.

Attack the track with the TYROLIA AAAttack Freeski bindings! Overcome boundaries - simply just: Access All Areas!

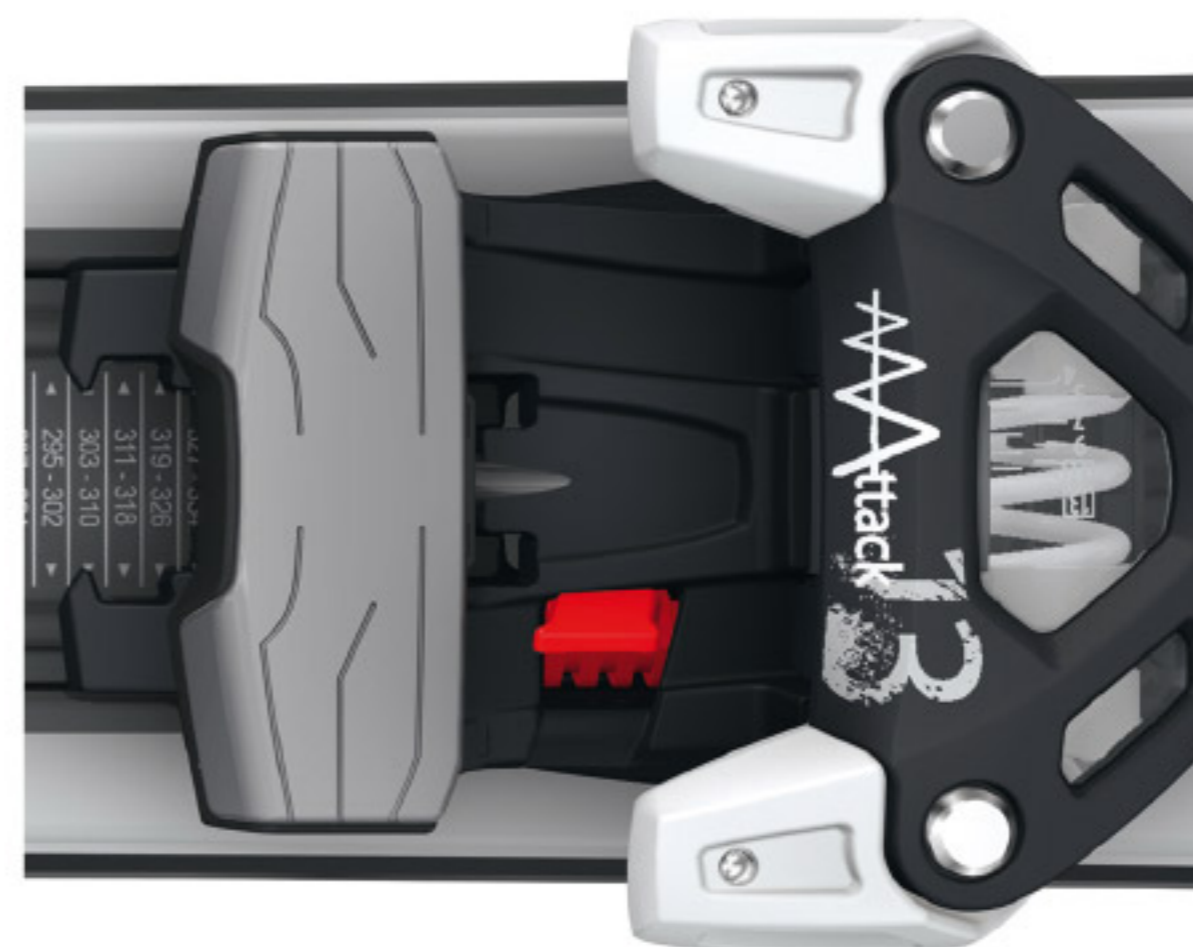

FREEFLEX PRO 20 X RD

ART.N°: 100500 FREEFLEX PRO 20 X RD

WHEN YOU'RE SPEEDING DOWN THE MOUNTAIN, TIME IS NOT ON YOUR SIDE. BUT THIS BINDING IS. OR MAYBE BETTER: IT SHOULD BE UNDER YOUR BOOTS.

FEATURES

AERO Toe with TRP System • Race Diagonal • Delrin • Freeflex Pro • RACE PRO Heel • Dura-Coating

STAND HEIGHT

16 mm

DIN

10-20

WEIGHT

3050 g

COLORS

White/Black/Flash Yellow



FREEFLEX PRO 20 X RS

ART.N°: 100501 FREEFLEX PRO 20 X RS

OUR WORLD CUP REBELS TRUST THESE BINDINGS WITH THEIR LIVES BLASTING THROUGH GATES AT 100+ KPH. YOU CAN TOO.

FEATURES

AERO Toe with TRP System • Race Diagonal • Delrin • FREEFLEX Pro • RACE PRO Heel • Dura-Coating

STAND HEIGHT

16 mm

DIN

10-20

WEIGHT

3050 g

COLORS

White/Black/Flash Yellow

FREEFLEX PRO 18 X

ART.N°: 100502 FREEFLEX PRO 18 X

BEING THE FASTEST NEVER WAS A MATTER OF LUCK. IT HAS ALWAYS BEEN A MATTER OF ATTITUDE, SKILL AND EQUIPMENT.

FEATURES

AERO Toe with TRP System • Race Diagonal • Teflon • FREEFLEX Pro • RACE PRO Heel • Dura-Coating

STAND HEIGHT

17 mm

DIN

8-18

WEIGHT

3030 g

COLORS

White/Black/Flash Yellow



FREEFLEX PRO 16 X RD/EP

ART.N°: 100505 FREEFLEX PRO 16 X RD/EP

THIS BINDING ENSURES THAT YOU AND YOUR SKIS ACT AS ONE.

FEATURES

AERO Toe with TRP System • Race Diagonal • Delrin • FREEFLEX Pro • RACE PRO Heel • Dura-Coating

STAND HEIGHT

16 mm

DIN

8-16

WEIGHT

3090 g

COLORS

White/Black/Flash Yellow



FREEFLEX PRO 16

ART.N°: 100506 FREEFLEX PRO 16

IF FAST IS NOT FAST ENOUGH AND SECOND PLACE IS FOR LOSERS, THEN THE FREEFLEX IS YOUR BINDING.

FEATURES

AERO Toe with TRP System • Race Diagonal • ABS - Anti Blocking System • FREEFLEX Pro • RACE PRO Heel • Dura-Coating

STAND HEIGHT

19,0 mm

DIN WEIGHT

5-16 2700 g

COLORS

White/Black/Flash Yellow



FREEFLEX PRO 14

ART.N°: 100508 FREEFLEX PRO 14

A BINDING FOR ALL THE WINNERS OUT THERE. WITH LD HEEL FOR ULTIMATE RELEASE ACTION AND UNHINDERED FLEX ACROSS THE ENTIRE SKI.

FEATURES

LX Toe with TRP System • Full Diagonal • ABS - Anti Blocking System • FREEFLEX Pro • LD Heel • Dura-Coating

STAND HEIGHT

21,0 mm

DIN WEIGHT

4-14 2330 g

COLORS

White/Black/Flash Yellow



FREEFLEX PRO 11

ART.N°: 100510 FREEFLEX PRO 11

FIS APPROVED GEOMETRY WITH ULTIMATE RELEASE PERFORMANCE FOR COMPETITIVE SKIERS. FEATURES RACE LITE HEEL.

FEATURES

LX Toe with TRP System • Full Diagonal • ABS - Anti Blocking System • FREEFLEX Pro • RACE Lite Heel • Dura-Coating

STAND HEIGHT

21,0 mm

DIN WEIGHT

3-11 2290 g

COLORS

White/Black/Flash Yellow



PRD 14

ART.N°: 100430 PRD 14

FAST, TIGHT, PRECISE POWER TRANSMISSION RAIL TO RAIL IN ANY SITUATION. AND ADJUSTABLE BY HAND.

FEATURES

- AERO Toe with TRP System
- Race Diagonal • ABS – Anti Blocking System • TriFlex Base
 - LD Heel • Dura-Coating

STAND HEIGHT

33,5 mm

DIN

4-14

WEIGHT

2210 g

COLORS

Matt Black/Stone



PRD 14 S

ART.N°: 100513 PRD 14 S BRAKE 80 [F]
ART.N°: 100514 PRD 14 S BRAKE 88 [F]

WELCOME TO THE FAST LANE IN BINDING TECHNOLOGY EVOLUTION. FEATURES LX TOE WITH TRP SYSTEM AND RACE DIAGONAL. ADJUSTABLE BY HAND.

FEATURES

- LX Toe with TRP System • Full Diagonal • ABS - Anti Blocking System • TriFlex Base • LD Heel
- Dura-Coating

STAND HEIGHT

33,5 mm

DIN

4-14

WEIGHT

2090 g

COLORS

Matt Black/Flash Yellow

PRX 12 S

ART.N°: 100522 PRX 12 S BRAKE 80 F
ART.N°: 100523 PRX 12 S BRAKE 88 F

ITS VERSATILITY MAKES THIS BINDING PERFECT FOR ALL HIGH SPEED ON AND OFF-PISTE PERFORMANCES. BESIDES THESE BENEFITS IS IT ADJUSTABLE BY HAND.

FEATURES

- LX Toe with TRP System • Full Diagonal • AFS • TriFlex Base
- RACE Lite Heel • Dura-Coating

STAND HEIGHT

33,5 mm

DIN

3,5-12

WEIGHT

1940 g

COLORS

Matt Black/Flash Yellow



PRD 12

ART.N°: 100520 PRD 12 BRAKE 80 [F]
ART.N°: 100521 PRD 12 BRAKE 88 [F]

THE PRD 12 COMBINES MAXIMUM FLEXIBILITY WITH PERFECT POWER TRANSMISSION WHILE BEING THE MOST CONVENIENT FOR HANDLING RETAIL, DEMO OR RENTAL.

FEATURES

- LX Toe with TRP System • Full Diagonal
- ABS - Anti Blocking
- System PowerRail
- LD Heel
- Dura-Coating

STAND HEIGHT

33,5 mm

DIN

3,5-12

WEIGHT

2090 g

COLORS

Matt Black/White



PR 11

ART.N°: 100568 PR 11 BRAKE 78 [G] MATT BLACK/WHITE
ART.N°: 100567 PR 11 BRAKE 90 [G] MATT BLACK/WHITE
ART.N°: 100566 PR 11 BRAKE 78 [G] WHITE / BLACK / FLASH YELLOW
ART.N°: 100384 PR 11 BRAKE 78 [G] WHITE / BLACK
ART.N°: 100527 PR 11 BRAKE 78 [G] MATT BLACK/RED
ART.N°: 100528 PR 11 BRAKE 78 [G] MATT BLACK/WHITE/ELECTRIC BLUE

MODULARLY BUILT TO MATCH ANY RIDER'S NEEDS, FROM AMATEUR TO PRO, AND EVERYTHING IN BETWEEN.

FEATURES

- SX Toe with TRP System • Full Diagonal
- AFS • PowerRail • SX Heel • Dura-Coating

STAND HEIGHT

31 mm

DIN

3-11

WEIGHT

1770 g

COLORS

Matt Black/White
Matt Black/White
White/Black/Flash Yellow
White/Black
Matt Black/Red
Matt Black/White/Electric Blue

TYROLIA LRX 9.0

ART.N°: 111637 TYROLIA LRX 9.0 BRAKE 78 [H] WHITE / WHITE
ART.N°: 111526 TYROLIA LRX 9.0 BRAKE 78 [H] SILVER / BLACK

ONE OF THE MOST LIGHTWEIGHT, CONVENIENT AND RELIABLE BINDINGS ON THE MARKET. EASILY ADJUSTABLE BY HAND.

FEATURES

- SX Toe with TRP System • Full Diagonal
- ABS - Anti Blocking System
- LiteRail • SL Lite
- Dura-Coating

STAND HEIGHT

28 mm

DIN

2,5-9

WEIGHT

1600 g

COLORS

White/White
Silver/Black



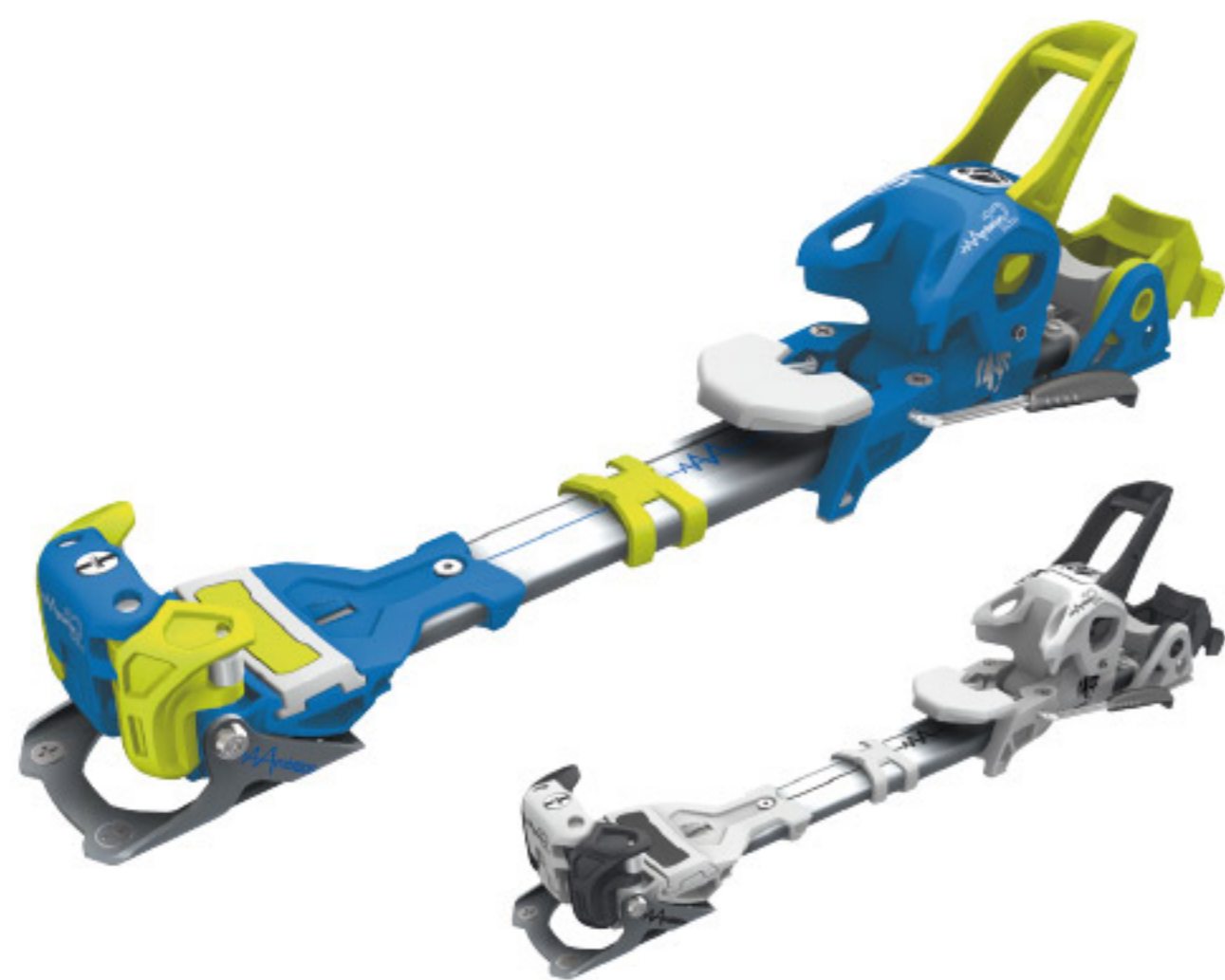

TYROLIA AAAMBITION 12

ART.N°: 111612 TYROLIA AAAMBITION 12 W/O BRAKE [C] SOLID BLUE/YELLOW
 ART.N°: 111610 TYROLIA AAAMBITION 12 W/O BRAKE [C] SOLID WHITE/BLACK

THE TYROLIA AAAMBITION 12 ALPINE TOURING BINDING IS THE PERFECT COMPANION FOR ALL ALPINE TOURING AFICIONADOS, SO THAT NO TERRAIN REMAINS UNATTAINABLE.

FEATURES

AT Toe • AFS • Telescopic Tube • AT Heel • w/o BRAKE [C] • Climbing Aid • Solid colored

STAND HEIGHT

38 mm

DIN

4-12

WEIGHT

1810 g (* 1980 g)

COLORS

Solid Blue/Yellow
 Solid White/Black

TYROLIA AAAMBITION 10

ART.N°: 111716 TYROLIA AAAMBITION 10 W/O BRAKE [C] SOLID WHITE/BLACK

FREEDOM, INNOVATIVE ADJUSTMENT POSSIBILITIES AND A PREMIUM HIGH-END PERFORMANCE – SIMPLY: TYROLIA AAAMBITION 10 ALPINE TOURING BINDING.

FEATURES

AT Toe • AFS
 • Telescopic Tube • AT Heel • w/o BRAKE [C] • Climbing Aid • Solid colored

STAND HEIGHT

38 mm

DIN

3-10

WEIGHT

1790 g (* 1960 g)

COLORS

Solid White/Black



TYROLIA AAADRENALIN 16 SHORT / LONG

ART.N°: 111604 TYROLIA AAADRENALIN 16 W/O BRAKE [B] SHORT SOLID BLACK / WHITE
ART.N°: 111605 TYROLIA AAADRENALIN 16 W/O BRAKE [B] LONG SOLID BLACK / WHITE

DESIGNED TOGETHER WITH FREESKIERS AND BACKCOUNTRY SKIERS, WITH AN ERGONOMIC WALKING MECHANISM FOR MAXIMUM FREEDOM ON-AND OFF-PISTE.

FEATURES

FR Pro Toe • AFS Metal • FR Pro Platform • FR Pro Heel • w/o BRAKE [B] • Climbing Aid
• Solid colored

STAND HEIGHT

38 mm

DIN

5-16

WEIGHT

2440 g (* 2740 g) - SHORT,
2460 g (*2760 g) - LONG

COLORS

Solid Black/White



TYROLIA AAADRENALIN 13 SHORT / LONG

ART.N°: 111606 TYROLIA AAADRENALIN 13 W/O BRAKE [F] SHORT SOLID BLACK/WHITE
ART.N°: 111607 TYROLIA AAADRENALIN 13 W/O BRAKE [F] LONG SOLID BLACK/WHITE

WHETHER SKIING DOWNHILL OR BRIDGING WALKING PATHS, THE TYROLIA AAADRENALIN FREERIDE BINDING PROVIDES ACCESS TO ALL AREAS.

FEATURES

FR Pro Toe • AFS Metal
• FR Pro Platform • FR Heel
• w/o BRAKE [F] • Climbing Aid
• Solid colored

STAND HEIGHT

39 mm

DIN

4-13

WEIGHT

2420 g (* 2720 g) - SHORT
2440 g (*2740 g) - LONG

COLORS

Solid Black/White

TYROLIA AAATTACK 16

ART.N°: 111615 TYROLIA AAATTACK 16 W/O BRAKE [A] SOLID BLACK/WHITE

A PERFECT TOOL FOR PARK&PIPE ACTION AND FOR SKIERS WHO ARE WILLING TO AAATTACK!

FEATURES

FR Pro Toe • AFD Metal
• RACE Pro Heel
• w/o BRAKE [A]
• Solid colored

STAND HEIGHT

17 mm

DIN

5-16

WEIGHT

1830 g (* 2130 g)

COLORS

Solid Black/White



* with BRAKE

TYROLIA AAATTACK 13

ART.N°: 111616 TYROLIA AAATTACK 13 BRAKE 97 [A] SOLID BLACK/WHITE
 ART.N°: 111618 TYROLIA AAATTACK 13 W/O BRAKE [A] SOLID BLACK/RED
 ART.N°: 111617 TYROLIA AAATTACK 13 W/O BRAKE [A] SOLID BLACK/WHITE

MODERN DESIGN –
 FUNCTIONALITY – PERFECT
 INDIVIDUALITY! FOR AN ASTON-
 ISHING PARK&PIPE AND PISTE
 PERFORMANCE.

FEATURES

FR Pro Toe • Metal • RACE Heel
 • w/o BRAKE [A] • Solid colored

STAND HEIGHT

17 mm

DIN

4-13

WEIGHT

1640 g (* 1940 g)

COLORS

Solid Black/White

Solid Black/Red



TYROLIA AAATTACK 13 DEMO

ART.N°: 111721 TYROLIA AAATTACK 13 DEMO W/O BRAKE [D]

THE TYROLIA AAATTACK 13
 DEMO IS THE FIRST FREESKI
 BINDING ANCHORED ON A
 METAL TOE TRACK.
 THE BENEFITS: LOW STAND
 HEIGHT, COMPACT DESIGN AND
 PERFECT STABILITY.

FEATURES

FR Pro Toe • AFD Metal • RACE One
 Touch Heel • Sympro Heel Track
 • w/o BRAKE [D] • Solid colored

STAND HEIGHT

23 mm

DIN

4-13

WEIGHT

2250 g (* 2550 g)

COLORS

Solid Black/White

TYROLIA PEAK 18 X

ART.N°: 111620 TYROLIA PEAK 18 X W/O BRAKE [A] MATT BLACK/WHITE

STANDING TALL AFTER A SICK
 TRICK IS WHAT FREESKIING
 IS ALL ABOUT. THE TYROLIA
 PEAK 18 X IS THE BINDING FOR
 PRO-LEVEL FREESKI ACTION.

FEATURES

AERO Toe with TRP System • Race
 Diagonal • Teflon Wide • RACE
 PRO Heel • w/o BRAKE [A] • Dura-
 Coating

STAND HEIGHT

17 mm

DIN

8-18

WEIGHT

2240 g (* 2540 g)

COLORS

Matt Black/White



TYROLIA PEAK 11

ART.N°: 111624 TYROLIA PEAK 11 BRAKE 90 [E] SOLID BLACK/WHITE
 ART.N°: 111726 TYROLIA PEAK 11 W/O BRAKE [E] SOLID BLACK/WHITE

THE BINDING FOR HIGH PER-
 FORMANCE FREESKI ACTION.
 FEATURES TYROLIA SX TOE
 WITH TRP SYSTEM, FULL
 DIAGONAL TECHNOLOGY AND
 TYROLIA SX HEEL.

FEATURES

SX Toe with TRP System • Full
 Diagonal • Teflon Wide • SX Heel
 • Solid colored

STAND HEIGHT

21 mm

DIN

3-11

WEIGHT

1320 g (* 1620 g)

COLORS

Solid Black/White



* with BRAKE

TYROLIA AAATTACK 12

ART.N°: 111722 TYROLIA AAATTACK 12 BRAKE 115 [A] SOLID WHITE/MINT

FREESKIERS PREFER EQUIPMENT WHICH PROVIDES CONTROL, PERFORMANCE AND USABILITY. THIS ONE'S EXTRA FEATURE: GOOD-LOOKING. FOR A PERFECT MATCH TO THE NEW WOMEN'S BIG MOUNTAIN SKIS.

STAND HEIGHT

17 mm

DIN WEIGHT

3,5 -12 1940 g

COLORS

Solid White/Mint

FEATURES

FR Pro Toe • AFD Metal • Race Heel • BRAKE 115 [A] • Solid colored



JOY 11 SLR

ART.N°: 100573 JOY 11 SLR BRAKE 90 [H] WHITE/TEAL
ART.N°: 100574 JOY 11 SLR BRAKE 78 [H] BLACK GLOSSY/FLASH YELLOW

IN COMBINATION WITH THE NEW SUPERLITERAIL BASE, THE JOY 11 SLR PROVIDES EFFORTLESS SKIING AND PERFECT CONTROL, WITHOUT LIMITATION.

STAND HEIGHT

28 mm

DIN WEIGHT

3 -11 1620 g

COLORS

White/Teal
Black Glossy/Flash Yellow

FEATURES

LX Toe with TRP System • Full Diagonal • AFS • SuperLiteRail • SX Heel • Dura-Coating

JOY 9 SLR

ART.N°: 100575 JOY 9 SLR BRAKE 90 [H] WHITE/BLACK
ART.N°: 100576 JOY 9 SLR BRAKE 78 [H] MATT BLACK/TEAL

A SPECIFICALLY DESIGNED BINDING TO MATCH THE NEW WOMEN'S LINE AND TO SUPPORT THE NEW LIGHT WEIGHT AND HIGH PERFORMANCE FEATURES.

STAND HEIGHT

28 mm

DIN

2,5-9

WEIGHT

1590 g

COLORS

White/Black
Matt Black/Teal

FEATURES

SX Toe with TRP System
• Full Diagonal • AFS • SuperLiteRail
• SX Heel • Dura-Coating



SX 9 JR. RACE

ART.N°: 100547 SX 9 JR. RACE BRAKE 72 [J] WHITE/BLACK/FLASH YELLOW

THE BINDING THAT KEEPS MOMS AND DADS AT EASE AND SPEEDSTERS ON THE SLOPE.

FEATURES

- SX Toe with TRP System • Full Diagonal • Teflon
- SL Lite Heel
- Dura-Coating

STAND HEIGHT

21 mm

DIN

2,5 - 9

WEIGHT

1530 g

COLORS

White/Black/Flash Yellow



LRX 7.5 AC

ART.N°: 100436 LRX 7.5 AC BRAKE 78 [H] SOLID WHITE/BLACK

ONE OF THE MOST COMFORTABLE BINDINGS ON THE MARKET. GREAT ON MOUNTAIN PERFORMANCE TEAMED UP WITH DEADLY GOOD LOOKS.

FEATURES

- SX Junior Toe with TRP System
- Full Diagonal
- AFS Junior
- LiteRail
- SX Junior Heel
- Solid colored

STAND HEIGHT

28 mm

DIN

2 - 7,5

WEIGHT

1380 g

COLORS

Solid White/Black

LRX 4.5 AC / JOY 4.5 AC LRX

ART.N°: 100441 LRX 4.5 AC BRAKE 74 [I] SOLID WHITE/BLACK
ART.N°: 100572 JOY 4.5 AC LRX BRAKE 74 [I] SOLID WHITE/PINK/BLUE

ONE OF THE MOST LIGHTWEIGHT, CONVENIENT AND RELIABLE BINDINGS ON THE MARKET. EASILY ADJUSTABLE BY HAND.

FEATURES

- SX Kid Toe with TRP System • Full Diagonal • AFS Junior
- LiteRail • SX Kid Heel • Solid colored

STAND HEIGHT

28 mm

DIN

0,75 - 4,5

WEIGHT

1270 g

COLORS

Solid White/Black
Solid White/Pink/Blue



TYROLIA SX 7.5 AC

ART.N°: 111654 TYROLIA SX 7.5 AC BRAKE 72 [J] SOLID WHITE/BLACK
ART.N°: 111549 TYROLIA SX 7.5 AC BRAKE 72 [J] SOLID BLACK/SILVER

SAFETY FIRST FOR LITTLE RIDERS AND THE SONIC YOUTH. FEATURES TYROLIA SX TOE WITH TRP SYSTEM AND TYROLIA SX JUNIOR HEEL.

FEATURES

- SX Junior Toe with TRP System • Full Diagonal • AFS Junior
- SX Junior Heel
- Solid colored

STAND HEIGHT

21 mm

DIN

2 - 7,5

WEIGHT

1400 g

COLORS

Solid White/Black
Solid Black/Silver



TYROLIA SX 4.5 AC

ART.N°: 111554 TYROLIA SX 4.5 AC BRAKE 74 [K] SOLID BLACK/SILVER
 ART.N°: 111555 TYROLIA SX 4.5 AC BRAKE 74 [K] SILVER/BLACK
 ART.N°: 111556 TYROLIA SX 4.5 AC BRAKE 74 [K] SOLID RED/BLACK
 ART.N°: 111569 TYROLIA SX 4.5 AC BRAKE 74 [K] SOLID WHITE/BLUE/PINK
 ART.N°: 111557 TYROLIA SX 4.5 AC BRAKE 74 [K] SOLID WHITE/BLACK

NO BETTER WAY TO START:
 THE ICONIC TYROLIA KIDS
 BINDINGS FOR LIGHT WEIGHT
 JUNIORS. FEATURES TYROLIA
 SX KID TOE WITH TRP SYSTEM
 AND TYROLIA SX KID HEEL.

COLORS

- Solid Black/Silver
- Silver/Black
- Solid Red/Black
- Solid White/Blue/Pink
- Solid White/Black

FEATURES

- SX Kid Toe with TRP System
- Full Diagonal • AFS Junior
 - SX Kid Heel • Dura-Coating
 - Solid colored

STAND HEIGHT

15 mm

DIN

0,75 - 4,5

WEIGHT

1190 g



TYROLIA PEAK 7.5 AC

ART.N°: 111627 TYROLIA PEAK 7.5 AC BRAKE 90 [J] SOLID BLACK/WHITE

THE BINING FOR
 SOLID FREESKI
 ACTION. FEATURES
 TYROLIA SX JUNIOR
 TOE WITH TRP SYS-
 TEM, FULL DIAGO-
 NAL TECHNOLOGY,
 AFS JUNIOR AND
 TYROLIA SX JUNIOR
 HEEL.

FEATURES

- SX Junior Toe with
 TRP System • Full
 Diagonal • AFS Junior
- SX Junior Heel
 - BRAKE 90 [J]
 - Solid colored

STAND HEIGHT

21 mm

DIN

2 - 7,5

WEIGHT

1400 g

COLORS

Solid Black/White



TYROLIA PEAK 4.5 AC

ART.N°: 111628 -TYROLIA PEAK 4.5 AC BRAKE 84 [K] SOLID BLACK/WHITE

PARK&PIPE COM-
 BINED WITH
 MAXIMUM SAFE-
 TY? THIS IS THE
 TYROLIA PEAK 4.5
 AC – START YOUR
 FREESKI EXPERI-
 ENCE WITH THE
 TYROLIA PEAK!

FEATURES

- SX Kid Toe with
 TRP System • Full
 Diagonal • AFS Junior
- SX Kid Heel
 - BRAKE 84 [K]
 - Solid colored

STAND HEIGHT

15 mm

DIN

0,75 - 4,5

WEIGHT

1190 g

COLORS

Solid Black/White





h

PROTECTION



WELCOME TO HEAD PROTECTION 14.15

Head's advanced sport protection delivers maximum defense against the innate dangers of mountain sports and their natural environs. We achieve this through innovation, the integration of next level materials and extensive R&D both in the lab and on the hill. Head Protection provides a safe zone in which athletes of all levels can participate, progress and enjoy. Add to this contemporary design and aesthetics and you have protection that athletes should wear and want to wear.

Head Protection breeds confidence: confidence breeds progression.

TIME TO GET SERIOUS

HEAD LAUNCHES

A NEW HELMET TECHNOLOGY

BY USING A
REVOLUTIONARY
IMPACT ABSORBING
MATERIAL.



INNOVATIVE

This is the start of a new era in helmet construction: SOFT CORE. The innovative DELTACELL TECHNOLOGY builds the core of the helmet, increasing comfort & fit, and hence safety.

SAFETY

The best helmet is the one you don't even feel it's on your head. The soft DELTACELL TECHNOLOGY adapts perfectly to the head, creating a snug fit for increased safety.

COMFORT

The soft DELTACELL TECHNOLOGY with its characteristic pattern adapts itself to the wearers head individually, avoiding pressure points. This makes the A|SERIES outstanding in terms of comfort.

AIRFLOW

DELTA CELL has an open structure. This enables a constant airflow for a comfortable helmet climate.



1 Original shape



2 Adapts to head form



3 Original shape

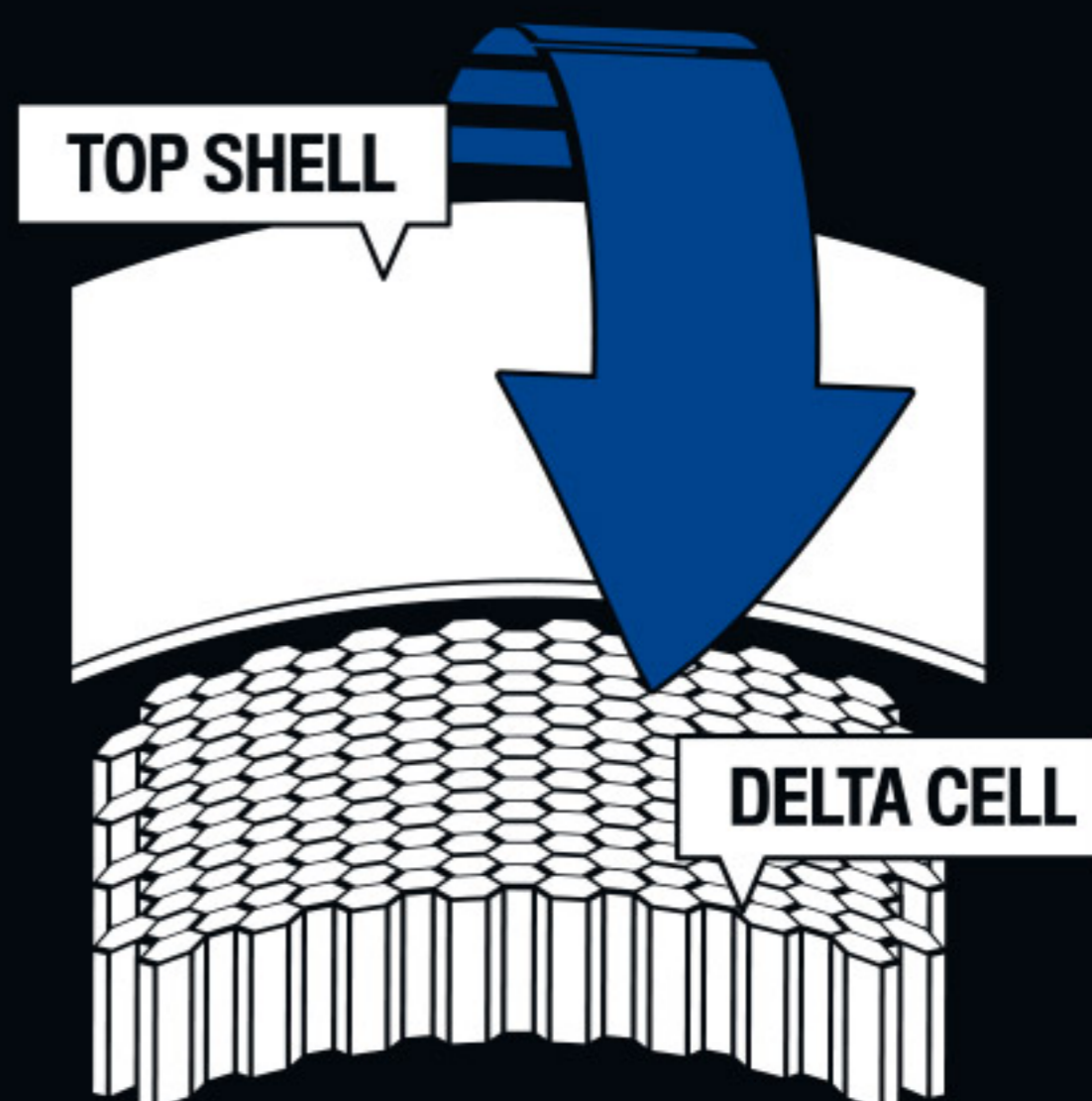

TECHNOLOGY

PROTECTION

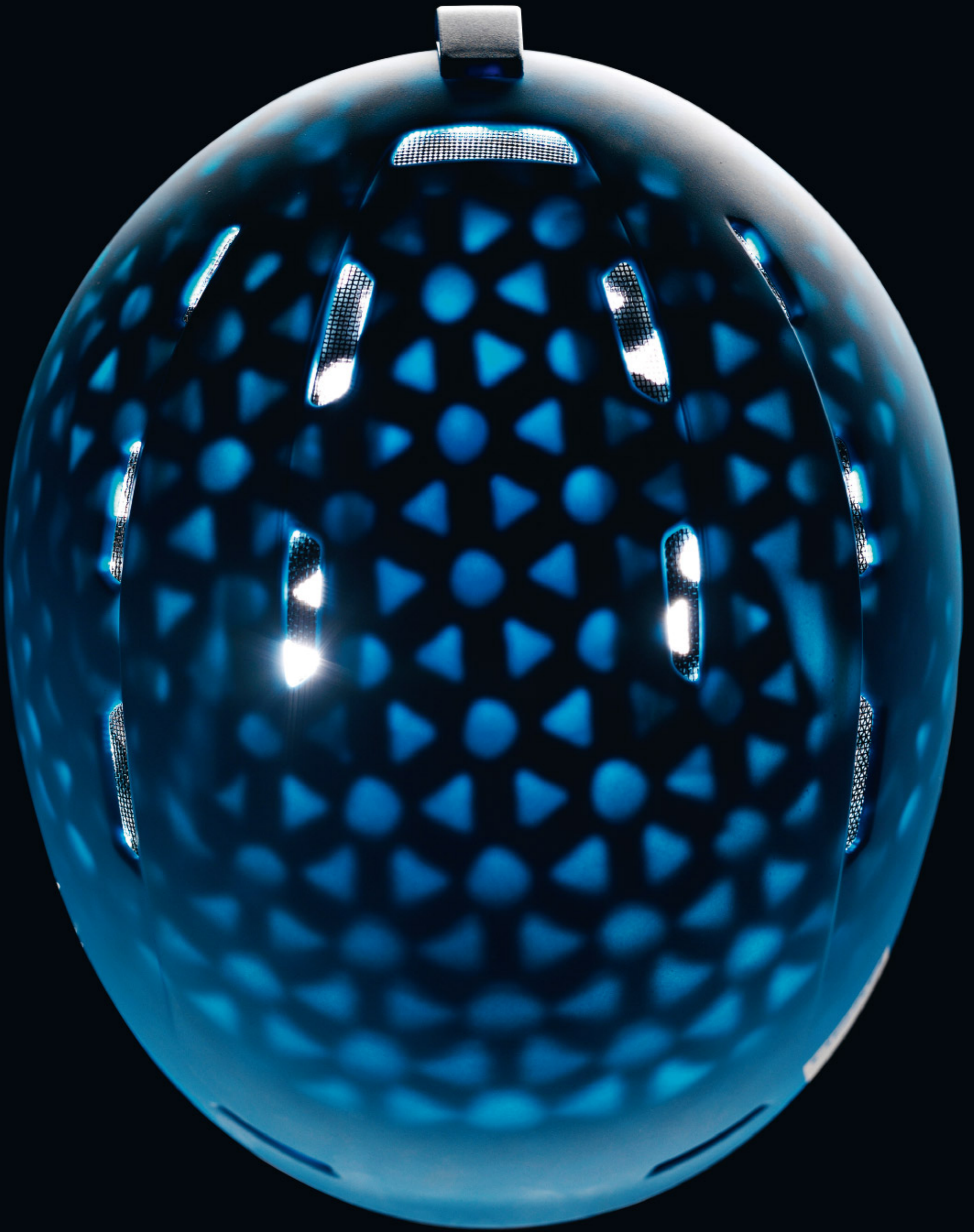

A|SERIES



TECHNOLOGY

PROTECTION

NEW TECHNOLOGY

TIME TO GET SERIOUS

THE ALL NEW AISERIES

ALPHA

ADORE

AGENT

AVRIL

THE HAIRPORT

REAL WOMAN FEATURES

The asymmetric positioning of the dial creates a HAIRPORT for ponytails.

HELMET TECHNOLOGY

OVERVIEW

CONSTRUCTION



LIGHT SHELL

We use the LIGHT SHELL for all InMould helmets with polycarbonate outer shells. Here the shock-absorbing EPS foam core is injected directly into the PC shell. The two components bind together and offer perfect protection and a low weight.



CARBON SHELL

The helmets shell is made from carbon fibres, which increases safety and decreases weight. This is why this technology is used for our racing helmets.



TOUGH SHELL

The classic dual construction made up of the ABS outer shell and the shock-absorbing EPS foam core is matchless in terms of longevity and impact strength. For this reason we use this construction for our STIVOT series helmets and for all the helmets in our rental range.



CONEHEAD SANDWICH CORE

The particular, pyramid-like structure of the two-layer foam ensures that shocks are better absorbed and that the impact energy is extensively distributed over the helmet. An innovative construction by means of which we brake the mold in the design of winter sports helmets.

MONO CORE

The shock absorbing inner layer of the MONO core is injected through the hard outer polycarbonate layer to create a single comprehensive unit that provides perfect protection at a reduced weight.



DUAL DENSITY CORE

This patented core technology is made from EPS with dual densities. This increases the helmets impact performance and suitable according to the FIS RH 2013 standard.



DELTACELL CORE

The revolutionary DELTACELL core technology heralds a new era in helmet construction. Using innovative polymer technology, this soft helmet has outstanding impact performance and the ability, to adapt to individual head shapes.



LOWER MICROSHELL

The helmet body is also coated with polycarbonate in order to avoid scratches and dents in the foam.



TWIST STOP GOGGLE RETAINER

The Twist stop goggle retainer will keep the goggles exactly where they belong and avoids any slipping of the straps.



REMOVABLE BRIM

For some, it is a matter of style – for others, it is a matter of function: the removable brim gives the helmet a cap-like style and serves as a sun, snow or rain protection. The integrated vents ensure that the moisture of the goggles is transported away and that the goggles do not fog up.



HYBRID SHELL

Our new Hybrid Shell construction combines the advantages of the robust ABS technology with the lightweight In-Mould construction. Thus, we develop lightweight, extremely robust and durable helmets. Hybrid Shell helmets may be constructed slimmer, a fact that adds to the stylish look.



LOWER MICROSHELL

The helmet body is also coated with polycarbonate in order to avoid scratches and dents in the foam.

VENTILATION



ADJUSTABLE DUAL ZONE VENTILATION

The ventilation in the two air ducts may be optimally adjusted independently from each other by means of two slide controls at the front and back side of the helmet.



ADJUSTABLE VENTILATION

The opening of the ventilation ducts on the top of the helmet may be adjusted continuously by means of a slide control.



THERMAL VENTILATION

Thermal Ventilation is our automatic ventilation system which leads warm air away from the head to the outside without allowing any cold air to the inside.

LINING



SYMPATEX LINER

SYMPATEX liner ensures excellent climate control. The HIGH2OUT laminate guarantees fast, effective sweat removal from the head while blocking moisture from coming in from the outside.



BEANIE LINER

The soft Microfleece material of the Beanie Liner adapts perfectly to the head and thus avoids any bruises and the unpleasant entering of cold air. Molded-in mesh zones let heat and moisture escape to the outside and, together with the ventilation system, ensure a pleasant head climate.



WOMEN SPECIFIC BEANIE LINER

Women have a different head shape than men. This is why we developed a Beanie Liner for women which is exactly adapted to the anatomy of the female head. This was achieved by means of two differently thick padding zones made of soft Microfleece.



INTEGRATED LINER WINDSHIELD

If it is very cold or stormy, the forehead above the goggles may be exposed to extreme temperatures. The liner windshield integrated in the Beanie Liner may simply be folded down if required and will thus close the gap between helmet and goggles. A small feature with great effect.



VENT DAMS

On cold days on the slope, the vents of the Thermal Ventilation may easily be closed by means of the Vent Dams.



AUDIO SOLUTION WITH VOLUME CONTROL

Our audio-helmets are equipped with high-quality earphones in the soft ear pads. The volume control integrated in the earphone cable provides for easy handling.



AGION™ ANTIMICROBIAL LINING

We use an antimicrobial Agion™ material for our liners. The combination of disinfecting silver ions and a preceramic coating makes the surface antimicrobial and the helmet remains odorless.



PERFORATED SOFT MICROFLEECE

The soft Microfleece material has two functions: it feels pleasant on the skin, absorbs moisture and transports it away from the head.



SOFT VELVET

A soft and at the same time durable material which absorbs the moisture and thus keeps the head dry.

EARPADS / NECK



HEIGHT ADJUSTABLE EARPADS

Due to the fact that not all people have their ears at the same height, we developed a patented system for the height adjustment of the ear pads. This system guarantees an optimal hearing and perfect fit of the helmet. Of course you can completely remove our ear pads including Neckgator on warm days or for cleaning purposes.



3D FIT

Head 3D Fit allows an exact horizontal as well as vertical adjustment of the helmet to the shape of your head.



2D FIT

The size adjustment system may be varied horizontally in order to individually adjust the helmet to your head.



REMOVABLE EARPADS

These ear pads and neckgator can be removed to suit the variable weather conditions and for cleaning.



HAIRPORT

The asymmetric positioning of the dial creates a HAIRPORT for ponytails.



BOA 360°

The 360° FIT system by BOA evenly adjusts the fit of the helmet to all shapes of head.

HELMET

FITTING

1

FIND THE RIGHT SIZE

Measure your head circumference with a tape measure which you apply above your ears. You will find the correct helmet size for your head circumference in the table below.



2

PUTTING ON THE HELMET AND ADJUSTING THE CHIN STRAPS

The helmet shall sit tightly on your head directly above your eyebrows. Adjust the two chin straps so that they solidly fix and hold the helmet.



3

CHECK FIT WITH GOGGLES

In order to check the perfect fit of the helmet, please put on your goggles. There should be no gap at all or an only small gap between the upper edge of your goggles and the helmet.



SIZES AND HEAD CIRCUMFERENCE

Model	Size (cm)	XS	S	M	L	XL	XXL
STIVOT RACE	52-53	54-55	56-57	58-59	60-61	62-63	
STIVOT RACE YOUTH	52-53	54-55	56-57	58-59			
SLALOM RACING CHINGUARD for helmet size	XS/S	XS/S	M/L	M/L	XL/XXL	XL/XXL	

Model	Size (cm)	XXS	XS/S	M/L	XL/XXL
CREST, ALPHA, AGENT, SENSOR, BEACON, REBEL, STIVOT SL, VENTOR PRO R, VENTOR R			52-55	56-59	60-63
CARMA, ADORE, AVRIL, GRACE, CLOE, STIVOT YOUTH SL			52-55	56-59	
AI R YOUTH, VENTOR YOUTH R		49-51	52-55	56-59	
RENTAL SR			52-55	56-58	59-64
RENTAL JR		48-51	52-55	56-58	

Model	Size (cm)	XXS/XS	S/M
JOKER, STAR		49-52	53-56

STIVOT RACE CARBON

ART.N°: 320004 BLACK
 ART.N°: 320014 PINK
 ART.N°: 376103 SLALOM RACING CHINGUARD

THE STIVOT RACE, APPROVED BY
 THE HEAD WORLDCUP REBELS.

FEATURES

- Conform to FIS Specifications RH 2013
- CARBON shell
- DUAL DENSITY core
- THERMAL ventilation
- BEANIE liner
- METAL buckle
- CHINGUARD compatible

SIZES AND WEIGHT

XS	S	M
52-53 cm	54-55 cm	56-57 cm
		560 g

L	XL	XXL
58-59 cm	60-61 cm	62-63 cm

COLORS

Black
 Pink



STIVOT SL + CHINGUARD

ART.N°: 320404 BLACK
 ART.N°: 320414 PINK

THE STIVOT SL IS A VERSATILE HALF-SHELL
 HELMET WITH REMOVABLE CHINGUARD;
 IDEAL FOR RACING, FROM
 GATES TO GROOMERS.

FEATURES

- TOUGH shell
- RESPIRO core
- TPR goggle retainer
- THERMAL ventilation
- BEANIE liner
- HEAD 2D FIT
- METAL chinguard

SIZES AND WEIGHT

XS/S	M/L	XL/XXL
52-55 cm	56-59 cm	60-63 cm
		570 g

COLORS

Black
 Pink





ALPHA BT RUNTASTIC

ART.N°: 324014

STAY CONNECTED ON THE SLOPES! HEAD AND RUNTASTIC PARTNERED UP TO DEVELOP THE SMARTEST HELMET FOR WINTER SPORTS. THE BT UNIT CONNECTS EVERY SMARTPHONE STRAIGHT WITH THE HELMET, ENABLING FUNCTIONS LIKE LISTENING TO MUSIC OR TAKING PHONECALLS ON THE RUN.

FEATURES

- LIGHT ABS shell
- DELTACELL core
- SYMPATEX liner
- ACTIVE ventilation
- REMOVABLE earpads
- 360° BOA FIT
- BLUETOOTH unit
- incl. HEART RATE MONITOR
- incl. RUNTASTIC PRO APP

SIZES AND WEIGHT

XS/S	M/L	XL/XXL
52-53 cm	56-59 cm	60-63 cm
555 g		

ALPHA

ART.N°: 324054 BLACK
ART.N°: 324064 CYAN

FRESH DESIGN PLUS SOFT CORE DELTACELL PROTECTION: A NEW ERA IN HELMETS.

FEATURES

- LIGHT ABS shell
- DELTACELL core
- SYMPATEX liner
- ACTIVE ventilation
- REMOVABLE earpads
- 360° BOA FIT

SIZES AND WEIGHT

XS/S	M/L	XL/XXL
52-53 cm	56-59 cm	60-63 cm
530 g		

COLORS

Black
Cyan



SENSOR

ART.N°: 324212 BLACK
ART.N°: 324214 GREY
ART.N°: 324224 BLACK / METAL

AWARD WINNING PROTECTION
FOR GROOMERS.

FEATURES

- LIGHT shell
- MONO core
- LOWER MICROSHELL
- BEANIE liner
- Integrated LINER WINDSHIELD
- ADJUSTABLE ventilation
- HEIGHT ADJUSTABLE earpads
- Agion™
- HEAD 2D FIT

SIZES AND WEIGHT

XS/S	M/L	XL/XXL
52-55 cm	56-59 cm	60-63 cm
420 g		

COLORS

Black
Grey
Black/Metal



CREST

ART.N°: 324114 BLACK
ART.N°: 324124 BLUE

PROTECTING YOUR HEAD IN
THE BACKCOUNTRY.

FEATURES

- HYBRID shell
- CONEHEAD SANDWICH core
- SEAMLESS BEANIE liner
- Integrated LINER WINDSHIELD
- ADJUSTABLE DUAL ZONE ventilation
- HEIGHT ADJUSTABLE earpads
- Agion™
- HEAD 3D FIT

SIZES AND WEIGHT

XS/S	M/L	XL/XXL
52-55 cm	56-59 cm	60-63 cm
540 g		

COLORS

Black
Blue





AGENT

ART.N°: 324154 BLACK
 ART.N°: 324164 WHITE
 ART.N°: 324174 CHESTNUT

THE HELMET OF CHOICE FOR
 HEAD'S FREESTYLE TEAM.

FEATURES

- LIGHT ABS shell
- DELTACELL core
- BEANIE liner
- THERMAL ventilation
- REMOVABLE earpads
- 360° BOA FIT

SIZES AND WEIGHT

XS/S	M/L	XL/XXL
52-55 cm	56-59 cm	60-63 cm
530 g		

COLORS

Black
 White
 Chestnut

REBEL

ART.N°: 324603 AUDIO BLACK
 ART.N°: 324613 BLACK
 ART.N°: 324614 BLACK/GREY
 ART.N°: 324624 BLUE
 ART.N°: 324634 WHITE

HELMET CHOICE OF YOUNG BLOODS.

FEATURES

- LIGHT shell
- MONO core
- LOWER MICROSHELL
- BEANIE liner
- THERMAL ventilation
- REMOVABLE earpads
- HEAD 2D FIT
- REBEL AUDIO BLACK:

AUDIO solution with volume control

SIZES AND WEIGHT

XS/S	M/L	XL/XXL
52-55 cm	56-59 cm	60-63 cm
395 g		

COLORS

Audio Black
 Black
 Black/Grey
 Blue
 White





ADORE

ART.N°: 325054 WHITE
ART.N°: 325064 PURPLE

AN 'ALL IN' HELMET WITH DELTACELL TECHNOLOGY FOR WOMEN.

FEATURES

- LIGHT ABS shell
- DELTACELL core
- SYMPATEX liner
- ACTIVE ventilation
- REMOVABLE earpads
- 360° BOA FIT

SIZES AND WEIGHT

XS/S	M/L
52-55 cm	56-59 cm
	530 g

COLORS

White
Purple

CARMA

ART.N°: 325014 WHITE
ART.N°: 325024 GREY

PROTECTION FOR GIRLS WHO LIKE TO STRAY OUT OF BOUNDS.

FEATURES

- HYBRID shell
- CONEHEAD SANDWICH core
- SEAMLESS WOMAN SPECIFIC BEANIE liner
- Integrated LINER WINDSHIELD
- ADJUSTABLE DUAL ZONE ventilation
- HEIGHT ADJUSTABLE earpads
- Agion™
- HAIRPORT
- HEAD 2D FIT

SIZES AND WEIGHT

XS/S	M/L
52-55 cm	56-59 cm
	540 g

COLORS

White
Grey

**GRACE**

ART.N°: 325123 WHITE
ART.N°: 325134 SANDY
ART.N°: 325144 PURPLE

FULLY ADJUSTABLE HEAD PROTECTION FOR LADIES WITH COLOURFUL STYLE.

FEATURES

- LIGHT shell
- MONO core
- LOWER MICROSHELL
- WOMAN SPECIFIC BEANIE liner
- Integrated LINER WINDSHIELD
- ADJUSTABLE ventilation
- HEIGHT ADJUSTABLE earpads
- Agion™
- HAIRPORT
- HEAD 2D FIT

SIZES AND WEIGHT

XS/S	M/L
52-55 cm	56-59 cm
	420 g

COLORS

White
Sandy
Purple



AVRIL

ART.N°: 325214 BLACK
 ART.N°: 325224 GREY
 ART.N°: 325234 GLACIER

AVRIL INCLUDES DELTACELL TECHNOLOGY, FOR IMPROVED COMFORT AND IMPACT ABSORPTION. A HELMET FOR GIRLS WHO LIKE TO GO BIG.

FEATURES

- LIGHT ABS shell
- DELTACELL core
- BEANIE liner
- THERMAL ventilation
- REMOVABLE earpads
- 360° BOA FIT

SIZES AND WEIGHT

XS/S	M/L
52-55 cm	56-59 cm
	530 g

COLORS

Black
 Grey
 Glacier



CLOE

ART.N°: 325613 WHITE
 ART.N°: 325624 TURQUOISE
 ART.N°: 325634 WHITE/PINK
 ART.N°: 325644 PINK

THE HELMET OF CHOICE FOR FREESTYLING GIRLS.

FEATURES

- LIGHT shell
- MONO core
- LOWER MICROSHELL
- WOMAN SPECIFIC BEANIE liner
- THERMAL ventilation
- REMOVABLE earpads
- HAIRPORT
- HEAD 2D FIT

SIZES AND WEIGHT

XS/S	M/L
52-55 cm	56-59 cm
	390 g

COLORS

White
 Turquoise
 White/Pink
 Pink





STIVOT RACE YOUTH CARBON

ART.N°: 328004 BLACK
ART.N°: 328014 PINK

DESIGNED WITH SPEED IN MIND.

FEATURES

- Conform to FIS Specifications RH 2013
- CARBON shell
- DUAL DENSITY core
- THERMAL ventilation
- BEANIE liner
- Chinguard compatible

SIZES AND WEIGHT

XS	S	M
52-53 cm	54-55 cm	56-57 cm
		560 g

L
58-59 cm

COLORS

Black
Pink



STIVOT YOUTH SL + CHINGUARD

ART.N°: 328204 BLACK
ART.N°: 328214 PINK

THE ADAPTABLE HELMET FOR
TECHNICAL SKIING FROM GATES
TO GROOMERS.

FEATURES

- TOUGH shell
- RESPIRO core
- TPR goggle retainer
- THERMAL ventilation
- BEANIE liner
- HEAD 2D FIT

SIZES AND WEIGHT

XS/S	M/L
52-55 cm	56-59 cm
	570 g

COLORS

Black
Pink





JOKER

ART.N°: 328614 BLACK
ART.N°: 328624 WHITE

THE KID'S HELMET THAT IS BIG ON SAFETY FEATURES AND TECH.

FEATURES

- LIGHT shell
- MONO core
- THERMAL ventilation
- SOFT VELVET lining

SIZES AND WEIGHT

XXS/XS	S/M
49-52 cm	53-5 cm
	350 g

COLORS

Black
White

STAR

ART.N°: 328714 PINK
ART.N°: 328724 BLUE

FEATURES

- LIGHT shell
- MONO core
- THERMAL ventilation
- SOFT VELVET lining

SIZES AND WEIGHT

XXS/XS	S/M
49-52 cm	53-56 cm
	350 g

COLORS

Pink
Blue



GOGGLES TECHNOLOGY

OVERVIEW

FEATURES



EXTREME WIDE FIELD OF VISION

Head's goggles with an extra wide field of vision are perfect for racers, allowing a tight aerodynamic tuck without impaired vision.



SPARE LENSES INCLUDED



COMPATIBLE WITH ALL HEAD HELMETS

LENS

SPRAYED POLYCARBONATE DOUBLE LENS

Lightweight Polycarbonate lenses are up to 10 times more impact-resistant than plastic or glass lenses and provide 100% protection from harmful UV rays.

SPRAYED POLYCARBONATE SPHERICAL DOUBLE LENS

A spherical lens has a consistent vertical and horizontal curve for a true and clear field of vision.



UV400 PROTECTION

UV400 protection keeps out 100% of UVA and UVB light; 5% better than the level of protection approved by the EU.



ANTI FOG

Additional coating that provides maximum protection against unwanted lens fogging and moist scratching.

MATERIAL



TRIPLE-LAYER FOAM

Triple-layer foam keeps out the elements and provides maximum levels of comfort, performance and fit.



DOUBLE-LAYER FOAM

Double-layer foam delivers perfect fit and comfort and a balanced micro-climate within the goggle.

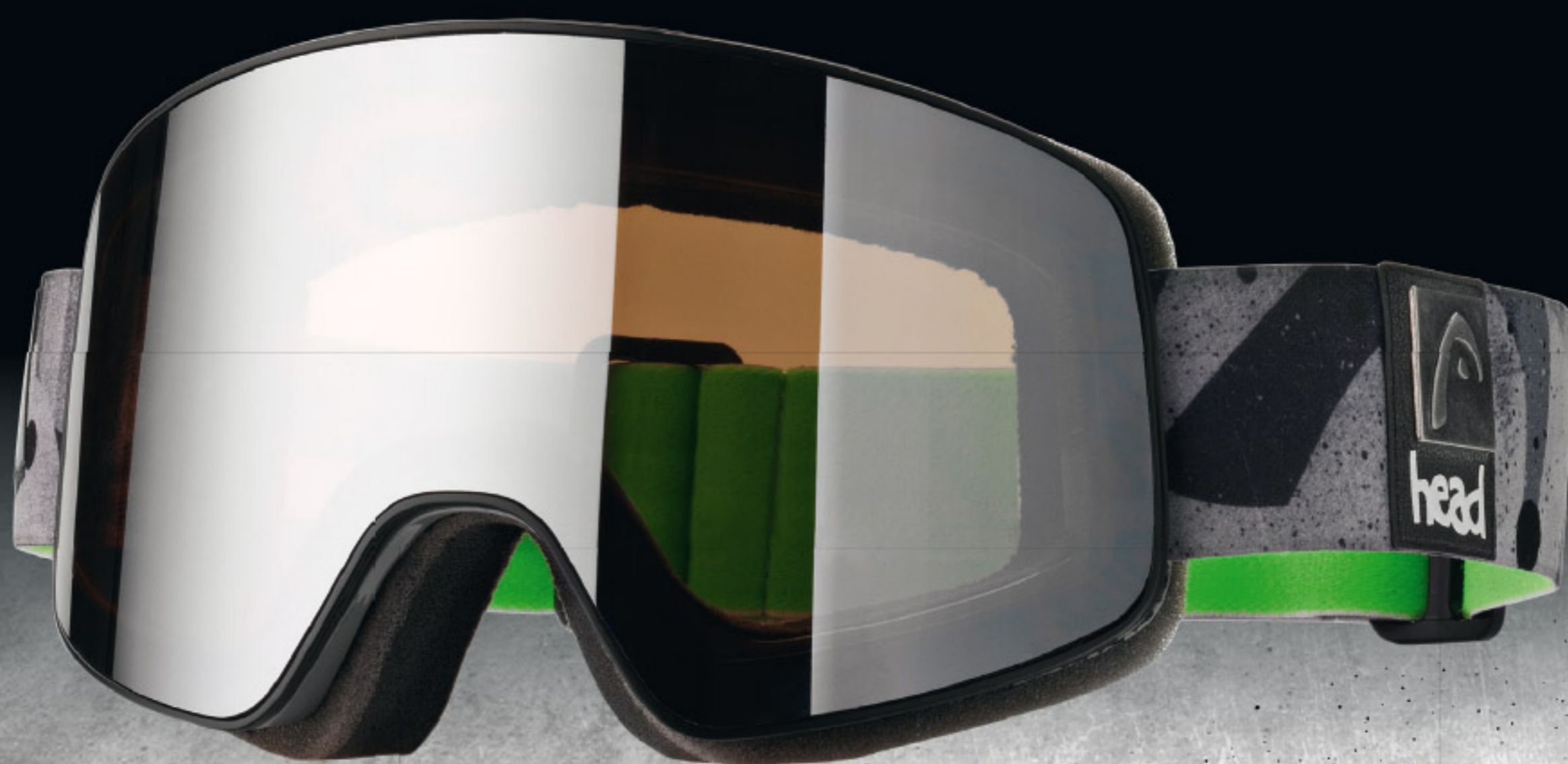



HORIZON RACE

ART.N°: 373314 BLACK + SPARELENS
ART.N°: 373324 LIME + SPARELENS

PERFECT FIT, OPTIMUM COMFORT,
UNRESTRICTED FIELD OF VISION.

FEATURES

- SPRAYED POLYCARBONATE double lens
- UV400 protection
- ANTI FOG
- TRIPLE-LAYER foam
- EXTREME WIDE FIELD OF VISION
- Compatible with all HEAD helmets
- SPARELENS included

COLORS

Black
Lime



SPARELENS



HORIZON LENS KIT

ART.N°: 373954

BAD WEATHER IS A MATTER
OF PERSPECTIVE.

DESCRIPTION	WEATHER	CATEGORY	UV PROTECTION	PERCENTAGE VLT	RECOMMENDED USAGE
CLEAR Lens, No coating		CAT 0	UV 400	87 %	the ideal lens for night time use, flood light
YELLOW lens, Silver mirror coating		CAT 1	UV 400	78 %	the ideal lens at fog and strong clouds
ORANGE lens, Silver mirror coating		CAT 2	UV 400	24,48 %	this lens increases contrasts, improves depth perception, good for all conditions
BLUE lens, Silver mirror coating		CAT 3	UV 400	14,09 %	reduces eye fatigue in bright and sunny conditions

STIVOT

ART.N°: 373114 BLACK + SPARELENS
ART.N°: 373124 BLUE + SPARELENS
ART.N°: 373134 BLACK
ART.N°: 373144 BLUE

CLEAR VISION FOR ALL-MOUNTAIN
AND FREESTYLE RIPPERS.

FEATURES

- SPRAYED POLYCARBONATE spherical double lens
- UV400 protection
- ANTI FOG
- TRIPLE-LAYER foam
- Compatible with all HEAD helmets
- SPARELENS included

COLORS

Black

Blue



SPARELENS



SPARK

ART.N°: 374514 WHITE

OPTIMUM FIT + MAXIMUM PROTECTION
+ STYLE.

FEATURES

- SPRAYED POLYCARBONATE double lens
- UV400 protection
- ANTI FOG
- DOUBLE-LAYER foam
- Compatible with all HEAD helmets

COLOR

White

NUKE

ART.N°: 374614 BLACK

HIGH-END GOGGLES WITH
A SMALL PRICE TAG.

FEATURES

- SPRAYED POLYCARBONATE double lens
- UV400 protection
- ANTI FOG
- DOUBLE-LAYER foam
- Compatible with all HEAD helmets

COLOR

Black



HORIZON

ART.N°: 373404 BLACK + SPARELENS
 ART.N°: 373424 WHITE + SPARELENS
 ART.N°: 373564 BLACK
 ART.N°: 373574 WHITE

LOOK RAD, SEE BETTER.

FEATURES

- SPRAYED POLYCARBONATE double lens
- UV400 protection
- ANTI FOG
- TRIPLE-LAYER foam
- EXTREME WIDE FIELD OF VISION
- Compatible with all HEAD helmets
- SPARELENS included

COLORS

Black

White



SPARELENS

SPARK

ART.N°: 374524 BLACK

OPTIMUM FIT + MAXIMUM
 PROTECTION + STYLE.

FEATURES

- SPRAYED POLYCARBONATE double lens
- UV400 protection
- ANTI FOG
- DOUBLE-LAYER foam
- Compatible with all HEAD helmets

COLOR

Black



NUKE

ART.N°: 374624 WHITE

HIGH-END GOGGLES WITH
 A SMALL PRICE TAG.

FEATURES

- SPRAYED POLYCARBONATE double lens
- UV400 protection
- ANTI FOG
- DOUBLE-LAYER foam
- Compatible with all HEAD helmets

COLOR

White





SPARELENS

HORIZON WMN

ART.N°: 373464 WHITE + SPARELENS
ART.N°: 373484 WHITE

PERFECT LOOK, PERFECT SIGHT.

FEATURES

- SPRAYED POLYCARBONATE double lens
- UV400 protection
- ANTI FOG
- TRIPLE-LAYER foam
- EXTREME WIDE FIELD OF VISION
- Compatible with all HEAD helmets
- SPARELENS included

COLOR

White

STIVOT WMN

ART.N°: 373154 PURPLE + SPARELENS
ART.N°: 373164 PURPLE

ALL-MOUNTAIN GOGGLE IN LADIES DESIGN.

FEATURES

- SPRAYED POLYCARBONATE spherical double lens
- UV400 protection
- ANTI FOG
- TRIPLE-LAYER foam
- Compatible with all HEAD helmets
- SPARELENS included

COLOR

Purple



SPARELENS



NINJA

ART.N°: 374712 BLACK
ART.N°: 374722 FLAMINGO

KIDS GOGGLES WITH NINJA QUALITIES.

FEATURES

- SPRAYED POLYCARBONATE double lens
- UV400 protection
- ANTI FOG
- DOUBLE-LAYER foam
- Compatible with all HEAD helmets

COLORS

Black

Flamingo

BODY PROTECTION

FITTING



REMOVABLE PROTECTION UNIT

The Protection Unit can be removed from the parent garment for ease of washing.



REMOVABLE SHOULDER STRAPS

Removable Shoulder Straps can be easily removed and reattached to comply with FIS regulations.



REMOVABLE PROTECTION UNIT



REMOVABLE SHOULDER STRAPS



ADJUSTABLE TROUSER CONNECTOR STRAPS

EXTRA WIDE WAIST BELT

The height adjustable waist belt measures 120mm in width and delivers a secure, comfortable fit.

SAS TEC VISCOELASTIC FOAM

Visco Elastic Foam is a soft, conformable, shock absorbent, temperature resistant material with a 10-year guaranteed lifespan; it also can take repeated beatings and still keep protecting.

POLYGIENE

Polygiene® permanent odor control technology is based on silver salt made from recycled silver. It neutralizes odor by stopping the growth of bacteria on the fabric, so you can wear more and wash less.

THERMO FLEECE

Thermo Fleece delivers warmth, wicks moisture, doesn't restrict movement, has a soft inner and durable, anti-pile treated exterior; tough, yet cosy.

3D MESH

3D Mesh is a three-dimensional fabric that allowing optimal air circulation between fabric and skin.

FLATLOCK SEAMS

High elasticity and tensile strength make Nylon 6 a good choice for applications where toughness, impact resistance and durability are critical.

1

Back protector

A back protector may only provide you with full protection if you have chosen the correct size and adjusted it to your body.

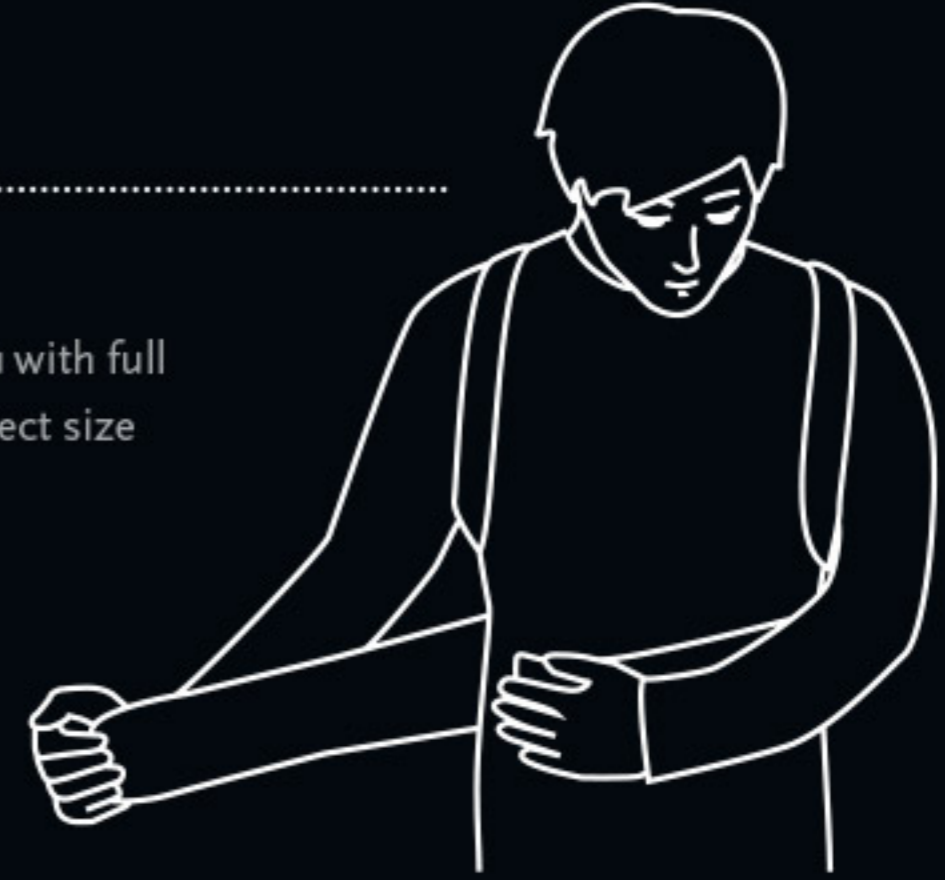

2

Adjust the Protector

Apply the protector and tighten the straps. The protector shall sit tight against the body without limiting the freedom of movement.

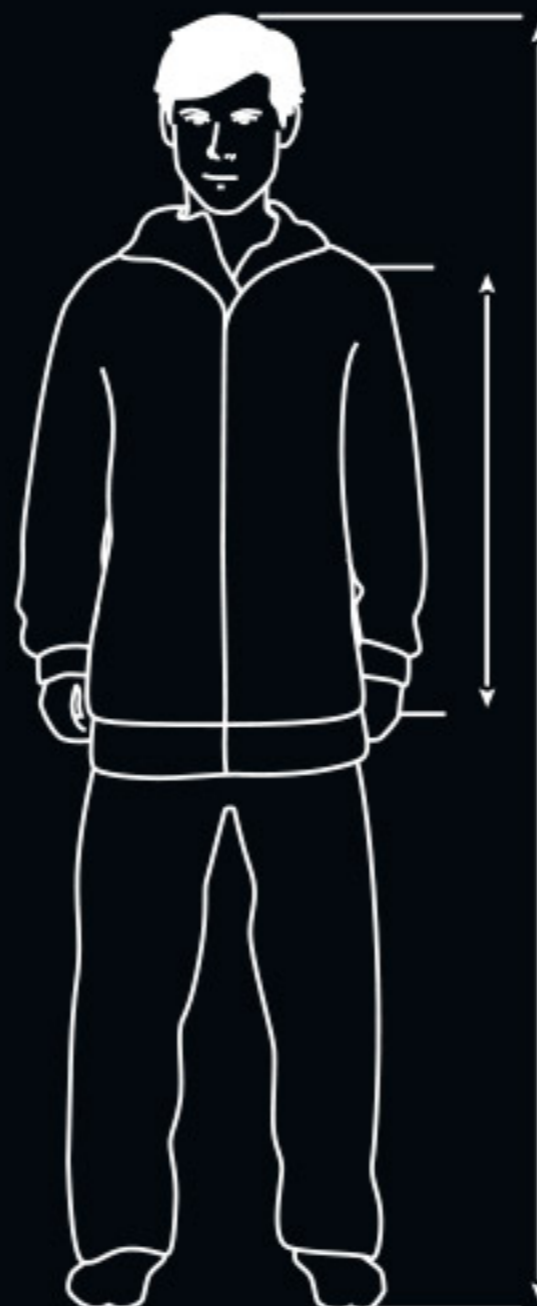

FLEXOR JACKET/VEST/UNIT UNISEX/MEN

SIZE	HT/CM	HT/INCH	1/CM	1/INCH
S	163	64,2	41	16
M	170	66,9	43	16,7
L	175	68,9	44	17,2
XL	188	74	47	18,5
XXL	212	83,5	53	20,9

FLEXOR VEST/UNIT WOMEN

SIZE	HT/CM	HT/INCH	1/CM	1/INCH
XS	155	61	44	17,4
S	163	64,2	47	18,3
M	170	66,9	49	19,1
L	175	68,9	50	19,7

FLEXOR JACKET/VEST JUNIOR

SIZE	HT/CM	HT/INCH	1/CM	1/INCH
116	130	51,2	37	14,6
128	140	55,1	40	15,7
140	150	59,1	43	16,9
152	160	63	46	18
164	175	68,9	50	19,7

FLEXOR UNIT RACE

ART.N°: 395314

FIS COMPLIANT BACK PROTECTION

FEATURES

- SAS TEC viscoelastic foam
- REMOVABLE protection unit
- EXTRA WIDE waist belt
- REMOVABLE shoulder straps
- 3D mesh
- POLYGIENE

SIZES

S - XXL



FLEXOR UNIT

ART.N°: 395324

CUSTOMIZABLE, SECURE AND FIS RACE COMPLIANT

FEATURES

- SAS TEC viscoelastic foam
- REMOVABLE protection unit
- EXTRA WIDE waist belt
- REMOVABLE shoulder straps
- 3D mesh
- POLYGIENE

SIZES

S - XXL





FLEXOR VEST

ART.N°: 395214

STAY WARM AND SAFE WITH MAXIMUM FREEDOM OF MOVEMENT.

FEATURES

- SAS TEC viscoelastic foam
- REMOVABLE protection unit
- EXTRA WIDE waist belt
- FLATLOCK seams
- POLYGIENE

SIZES

S - XXL

FLEXOR VEST WOMAN

ART.N°: 395614

FREEDOM OF MOVEMENT, WARMTH AND BACK PROTECTION ROLLED INTO ONE.

FEATURES

- SAS TEC viscoelastic foam
- REMOVABLE protection unit
- EXTRA WIDE waist belt
- FLATLOCK seams
- THERMO fleece
- POLYGIENE

SIZES

XS - L



FLEXOR JR UNIT RACE

ART.N°: 395824

FIS COMPLIANT BACK PROTECTION WITH IMPROVED FREEDOM OF MOVEMENT.

FEATURES

- SAS TEC viscoelastic foam
- REMOVABLE protection unit
- REMOVABLE shoulder straps
- 3D mesh
- POLYGIENE

SIZES

116, 128, 134, 152, 164



FLEXOR JR UNIT

ART.N°: 395814

FIS COMPLIANT BACK PROTECTION.

FEATURES

- SAS TEC viscoelastic foam
- REMOVABLE protection unit
- REMOVABLE shoulder straps
- 3D mesh
- POLYGIENE

SIZES

116, 128, 134, 152, 164



FLEXOR JR VEST

ART.N°: 395714

WARM BACK PROTECTION FOR GROMS.

FEATURES

- SAS TEC viscoelastic foam
- REMOVABLE protection unit
- EXTRA WIDE waist belt
- FLATLOCK seams
- POLYGIENE

SIZES

116, 128, 134, 152, 164





ABS® TWINBAG FOR LIFE



A QUICK TUG ON THE ABS® TWINBAG'S ACTIVATION HANDLE IS ALL IT TAKES TO INSTANTLY INFLATE TWO AIRBAGS WITH A TOTAL VOLUME OF 170 LITERS. THIS EXTRA VOLUME WILL ALMOST CERTAINLY PREVENT THE WEARER FROM BEING BURIED IN AN AVALANCHE.

Two separate airbag chambers make the ABS® system twice as reliable. If one airbag is damaged during the descent, the other will remain inflated for a sufficient length of time. The wide bearing surface due to laterally placed Twin-Bags stabilizes the body and increases the lifting effect precisely in the critical avalanche run-out zone. Of the 262 persons who activated their ABS® avalanche airbag, 97% survived and 84% of those were uninjured.*

* Source: SLF, known and documented avalanche accidents with ABS® avalanche airbags, August 2010.

ABS® COMPATIBLE*

The ABS® Avalanche Airbag is the original self-rescue system – produced and tested by German avalanche experts since 1985. There are also other, wellknown companies that rely on ABS® and have included backpacks in their product range that are compatible with the ABS®-System. This backpack is especially designed to fit onto the Base Unit with integrated ABS® TwinBag system by means of a zip.



REBELS TRAVELBAG

ART.N°: 383504

FEATURES

Big wheelie bag for ski pros and world travellers • Can be divided into two pieces • Additional zipper on the top for main compartment • Inline Skating wheels • Long stowable pull handle for easy carrying • Large additional compartment at the top • Special base fabric • Padded heavy-duty casing • Neon lining

DIMENSION

76 x 38 x 41 cm

VOLUME

103 l



REBELS BACKPACK

ART.N°: 383514

FEATURES

Daypack with integrated moulded and fleece lined goggle pocket • Anatomically designed back padding with fully adjustable padded dorsal strap system • Water and dirt repellent bottom fabric • 4 diagonal straps for skis, snowboard, snowshoes, ice axe and poles • Neon lining

DIMENSION

32 x 49 x 18 cm

VOLUME

23 l



REBELS RACING BACKPACK

ART.N°: 383554

FEATURES

Big backpack for racers coaches and tech-reps • New construction • Front and two side pockets • Big compartment at the top for helmet and accessories • Neon lining

DIMENSION

40 x 64 x 30 cm

VOLUME

68 l



REBELS DOUBLE SKIBAG

ART.N°: 383524

FEATURES

Protective bag for 2 pairs of skis
• Two wheels for carrying comfort
• Water and dirt repellent bottom fabric
• Padded main compartment with two buckles
• Easy-to-adjust compression straps
• Neon lining

DIMENSION

203 x 18 x 28 cm

VOLUME

106 l



REBELS HEATABLE BOOT BAG

ART.N°: 383544

FEATURES

Heatable boot backpack • Comfortable handles and stowable padded backpack straps • Padded goggle compartment • Various small zippered pockets for socks, bottles, gloves, clothing
• Adjustable helmet holder • Four way controller switch with house (110 / V or 220 / V) • DC plug in • Automotive cable plug in (12 / V) AC
• Three temperature settings:

Hot (70° C / 150° F)

Dry (60° C / 130° F)

Warm (50° C / 122° F)

DIMENSION

25 x 43 x 38 cm

VOLUME

40 l





SKI DAYPACK

ART.N°: 383744

FEATURES

Daypack with zippered main and an external compartment • Helmet holder • Ergonomic mesh back padding • Mesh water bottle pocket • Fleece lined goggle compartment

DIMENSION

33 x 18 x 48 cm

VOLUME

29 l



SINGLE SKIBAG

ART.N°: 383714

FEATURES

Protective skibag for one pair of skis
• Length 170 cm – extendable to 190 cm • Equipped with two buckled, easy-to-adjust compression straps and a comfortable carrying strap

DIMENSION

170 + 20 x 25 x 15 cm

VOLUME

54 l

DOUBLE SKIBAG

ART.N°: 383734

FEATURES

Protective bag for two pairs of skis
• Extendable to a length of 195 cm
• Equipped with two buckled, easy-to-adjust compression straps and a comfortable carrying strap

DIMENSION

170 + 25 x 31 x 15 cm

VOLUME

74 l



SKI TRAVELBAG

ART.N°: 383794

FEATURES

Big wheelie bag with large main and various small compartments • Stowable pull handle
• Business card window and high quality wheels

DIMENSION

79 x 32 x 36 cm

VOLUME

85 l



BOOT BACKPACK

ART.N°: 383764

FEATURES

Roomy zippered compartment and front pocket • PP lining • external zippered pouch • Backing ergonomically padded

DIMENSION

35 x 23 x 40 cm

VOLUME

25 l



BOOT BAG

ART.N°: 383754

FEATURES

Shapely boot-carry-on-bag with comfortable handles and shoulder strap • Zippered main and external compartment

DIMENSION

40 x 38 x 27 cm

VOLUME

34 l



FREERIDE SINGLE SKIBAG

ART.N°: 383624

FEATURES

Protective skibag for one pair of skis

- Length 170 cm – extendable to 190 cm
- Equipped with two buckled, easy-to-adjust compression straps and a comfortable carrying strap

DIMENSION

170 + 20 x 25 x 15 cm

VOLUME

54 l



FREERIDE BOOT BAG

ART.N°: 383614

FEATURES

Shapely boot-carry-on-bag with comfortable handles and shoulder strap • Zippered main and external compartment

DIMENSION

40 x 38 x 27 cm

VOLUME

34 l



SKI FREERIDE BACKPACK

ART.N°: 383534

FEATURES

- Waterproof zippers
- Horizontal and dual vertical ski carry options
- Vertical snowboard carry straps
- Storable ski carry and ice axe straps
- Internal snow tools and shovel pockets
- Helmet carrying system
- Sternum chest strap
- ABS compatible
- ABS Vario Unit is not included
- Fleece lined goggle compartment
- Water repellent fabric
- New designed back padding
- Water bottle pocket

DIMENSION

33 x 58 x 14 cm

VOLUME

33 l



STREET BACKPACK

ART.N°: 374483

FEATURES

- Water resistant nylon material
- Durable ripstop construction
 - Highquality YKK Zipper • Padded laptop pocket • Sound pocket
 - Ergonomic padded shoulder straps • Breathable lining
 - Inside storage system

DIMENSION

35 x 10 x 50 cm

VOLUME

17 l



LEARJET

ART.N°: 374433

FEATURES

- Water resistant nylon material • Durable ripstop construction
- Highquality YKK Zipper
 - Heavy duty webbing reinforcements • Bottom & edge protection
 - 3 stop telescope handle
 - Comfy neoprene handle

DIMENSION

55 x 35 x 28 cm

VOLUME

55 l



TRAVELBAG SM

ART.N°: 374423

FEATURES

- Water resistant nylon material
- Durable ripstop construction
 - Highquality YKK Zipper • Heavy duty webbing reinforcements
 - Bottom & edge protection
 - Velcro adjustable packing compartments • Laundry bag
 - 2 stop telescope handle
 - 3 Comfy neoprene handle

DIMENSION

75 x 40 x 30 cm

VOLUME

95 l



TRAVEL DUFFLE BAG

ART.N°: 374494

FEATURES

- Roomy zippered compartment and front pocket • PP lining
- external zippered pouch
 - Backing ergonomically padded

DIMENSION

50 x 27 x 24 cm

VOLUME

30 l



WOMAN SINGLE SKIBAG 170

ART.N°: 383814

FEATURES

A women-specific skibag for one pair of skis • Comfortable carrying straps and solid compression straps
• HEAD embroidery • Mint lining
• Metal pullers

DIMENSION

176 x 24 x 12 cm

VOLUME

58 l



WOMAN TRAVELBAG

ART.N°: 383804

FEATURES

Women-specific wheelee bag with telescope handle for easy pulling • Large zippered main compartment and various inner and outer compartments • Mint lining • Metal pullers

DIMENSION

64 x 37 x 32 cm

VOLUME

80 l



WOMAN BOOT BAG

ART.N°: 383834

FEATURES

Boot bag for one pair of boots
• Ergonomic shoulder strap
• Zippered main and external compartment • Mint lining
• Metal pullers

DIMENSION

40 x 38 x 27 cm

VOLUME

37 l



WORLD CUP SUPER G

ART.N°: 381023



FEATURES

- Original bent World Cup racing pole
- 7075 Aluminum
- Soft Downhill Grip
- Race Strap
- DH and SG Cone basket yellow 40 mm
- Carbide Tip Alpine

DIAMETER Ø

18 mm

LENGTHS

110 – 135 cm

COLORS

White/Black/Yellow

WORLD CUP SL

ART.N°: 381033



FEATURES

- SL Race Pole
- 7075 Aluminum
- Soft Downhill Grip
- Race Strap
- Race Basket yellow 50 mm
- Carbide Tip Alpine

DIAMETER Ø

18 mm

LENGTHS

110 – 140 cm

COLORS

White/Black/Yellow

SUPERSHAPE VIP

ART.N°: 381134



FEATURES

- High End Air Foil Pole
- 7075 Aluminum
- Positive Angle Safety Thermo Grip
- cw Neon Yellow Finish
- Lock Security strap
- Carbide Tip Alpine
- Alpine Race basket yellow 50 mm

DIAMETER Ø

16 AIR FOIL mm

LENGTHS

110 – 135 cm

COLORS

Black/White/Yellow

CARBON PRESTIGE

ART.N°: 381043



FEATURES

- Positive Angle Safety Thermo
- Grip cw Chrome Finish
- Lock Security strap
- Carbide Flex Tip Alpine
- Vision Race Basket 50mm

DIAMETER Ø

11 mm Carbon Shaft

LENGTHS

105 – 135 cm

COLORS

Carbon black/White/Yellow

HEAD CLASSIC NEON

ART.N°: 381914 NEON BLUE
ART.N°: 381924 NEON GREEN
ART.N°: 381934 NEON RED
ART.N°: 381944 NEON YELLOW



FEATURES

- 7075 Aluminum Brushed
- Positive Angle Safety Bi-Injected Soft Grip
- Lock Security Strap
- Alpine Race Basket 50 mm
- Ice Steel Tip

DIAMETER Ø

16 mm

LENGTHS

105 – 135 cm

COLORS

Neon Blue
Neon Green
Neon Red
Neon Yellow

MULTI S

ART.N°: 381154 BLACK SILVER
ART.N°: 381144 BLACK FLUORO

**FEATURES**

- Glossy Matt finish
- Bi-injected Grip
- Automatic Strap
- 5083 Aluminum

DIAMETER Ø

18 mm

Race Basket

Star Tip

LENGTHS

105 – 135 cm

COLORS

Black Silver

Black Fluoro

MULTI I

ART.N°: 381814 SILVER BLACK
ART.N°: 381824 WHITE RED
ART.N°: 381834 WHITE BLUE

**FEATURES**

- Ergo PE grip
- automatic strap
- 5086 aluminum

DIAMETER Ø

18 mm

Race Basket

Star Tip

LENGTHS

105 – 135 cm

COLORS

Silver Black

White Red

White Blue

VARIO TWO PIECE

ART.N°: 381514 BLACK/WHITE/RED



FEATURES

- Two-part telescope pole
- 7075 Aluminum
- Positive Angle Safety Bi-Injected Soft Grip
- c/w 14cm Foam Extension
- Lock Security Neoprene strap
- LEKI Speed Lock
- Carbide flex tip long
- Vision Race Basket 50 mm & Additional 95mm Powder Basket
- Packing Length 84 cm

DIAMETER Ø

16/14 mm

LENGTHS

110 - 140 cm adjustable

COLORS

Black/White/Red

VARIO THREE PIECE

ART.N°: 381523 RED/YELLOW



FEATURES

- Three-part telescope Touring pole
- 7075 Aluminum
- Round Top Comfort Soft Grip w/ Thermo Long
- Lock Security Strap, Fleece
- LEKI Speed Lock
- Carbide flex tip long
- 95mm Powder Basket
- Packing Length 70 cm

DIAMETER Ø

18/16/14 mm

LENGTHS

110 - 150 cm adjustable

COLORS

Red/Yellow

AERO

ART.N°: 381334 SUBLIMATED



FEATURES

- 7075 Aluminum
- Bi-injected Grip
- Automatic Strap
- Alpine Race Basket 50 mm White & 92 mm Powder Basket Blue
- ICE Carbide Tip

DIAMETER Ø

18 mm

LENGTHS

110 - 135 cm

COLOR

Sublimated

JOY WHITE

ART.N°: 381604 WHITE/BLUE



FEATURES

- High End Woman Pole
 - 7075 aluminum
- Positive Angle Safety Thermo
- Compact Grip w/ Chrome Finish
- Lock Security Compact Strap
 - Ice Steel Tip
- Alpine Race Basket 50 mm

DIAMETER Ø

16 mm

LENGTHS

110 - 130 cm

COLORS

White/Blue

JOY BLACK

ART.N°: 381674 BLACK/BLUE



FEATURES

- Women-specific SBS Soft Handle
 - Automatic Strap
 - 5086 Aluminum

DIAMETER Ø

16 mm

Race Basket

Star Tip

LENGTHS

105 - 125 cm

COLORS

Black/Blue

WORLD CUP SG JUNIOR

ART.N°: 381323
WHITE/BLACK/YELLOW



FEATURES

- Original bent JR World
- Cup racing pole
- 5086 Aluminum
- Soft Downhill Grip
- Buckle Strap
- DH and SG Cone basket yellow 40 mm
- Steel Tip

DIAMETER Ø

16 mm

LENGTHS

90 - 110 cm

COLORS

White/Black/Yellow

SUPERSHAPE TEAM

ART.N°: 381373
WHITE/BLACK/YELLOW

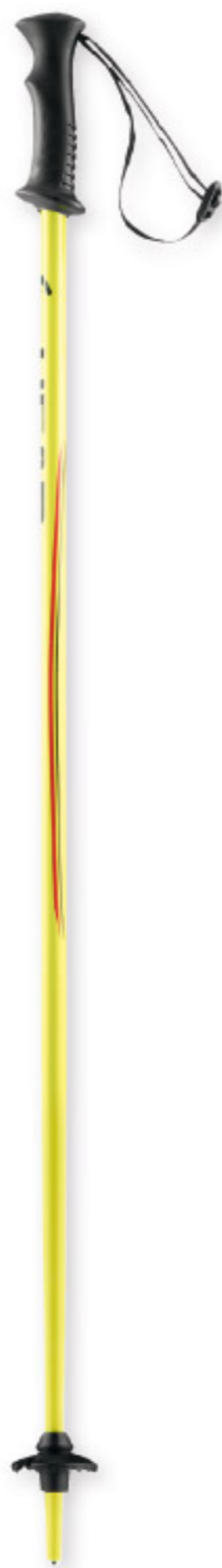

FEATURES

- Kids Plastic Grip
- Buckle strap Kids
- 5086 aluminum
- Alpine Race Basket 50 mm
- Steel Tip

DIAMETER Ø

14 mm

LENGTHS

70 - 110 cm

COLORS

White/Black/Yellow

AERO TEAM

ART.N°: 381394 SUBLIMATED



FEATURES

- Cosmetics sublimated
- Kids Plastic Grip
- Buckle strap Kids
- 5086 aluminum
- Alpine Race Basket 50 mm
- Steel Tip

DIAMETER Ø

14 mm

LENGTHS

70 - 110 cm

COLOR

Sublimated

JOY GIRL

ART.N°: 381614 SUBLIMATED



FEATURES

- Kids Plastic Grip white
- Buckle strap Kids
- 5086 aluminum
- Alpine Race Basket 50 mm white
- Steel Tip

DIAMETER Ø

14 mm

LENGTHS

70 - 110 cm

COLOR

Multicolored



RENTAL COMBO

**WHEN FIRST-TIMERS START THEIR
LIFELONG JOURNEY IN YOUR SHOP
WHEN THE ONLY TOOLS YOU NEED
ARE YOUR BARE HANDS
WHEN YOU HAVE EVERYBODY'S
FAVOURITE SKI IN STOCK
WHEN YOUR CUSTOMER IS GONE IN
60 SECONDS**

WHAT'S YOUR LIMIT?

Performance because rented skis ensure a perfectly prepared edge and base at all times, a current-year, perfectly fitting boot and a safely adjusted binding. All without the risks and worries of transport, age, maintenance, repair and the horrors of having bought the wrong product. HEAD's vision of rental is one of perfect accessibility and convenience in the valley and perfectly dialed performance on the mountain. A vision you might share.

WHEN FIRST-TIMERS START THEIR LIFELONG JOURNEY

ERA 3.0

Imagine a ski that performs for everyone, anywhere: One for all. All in one. HEAD ERA 3.0 is not your one-dimensional «Have a problem? We fix it!» technology. ERA 3.0 is a combination of technologies, shape and geometry. Think Rock er, think Radius, think Rebound. Think 3-dimensional.

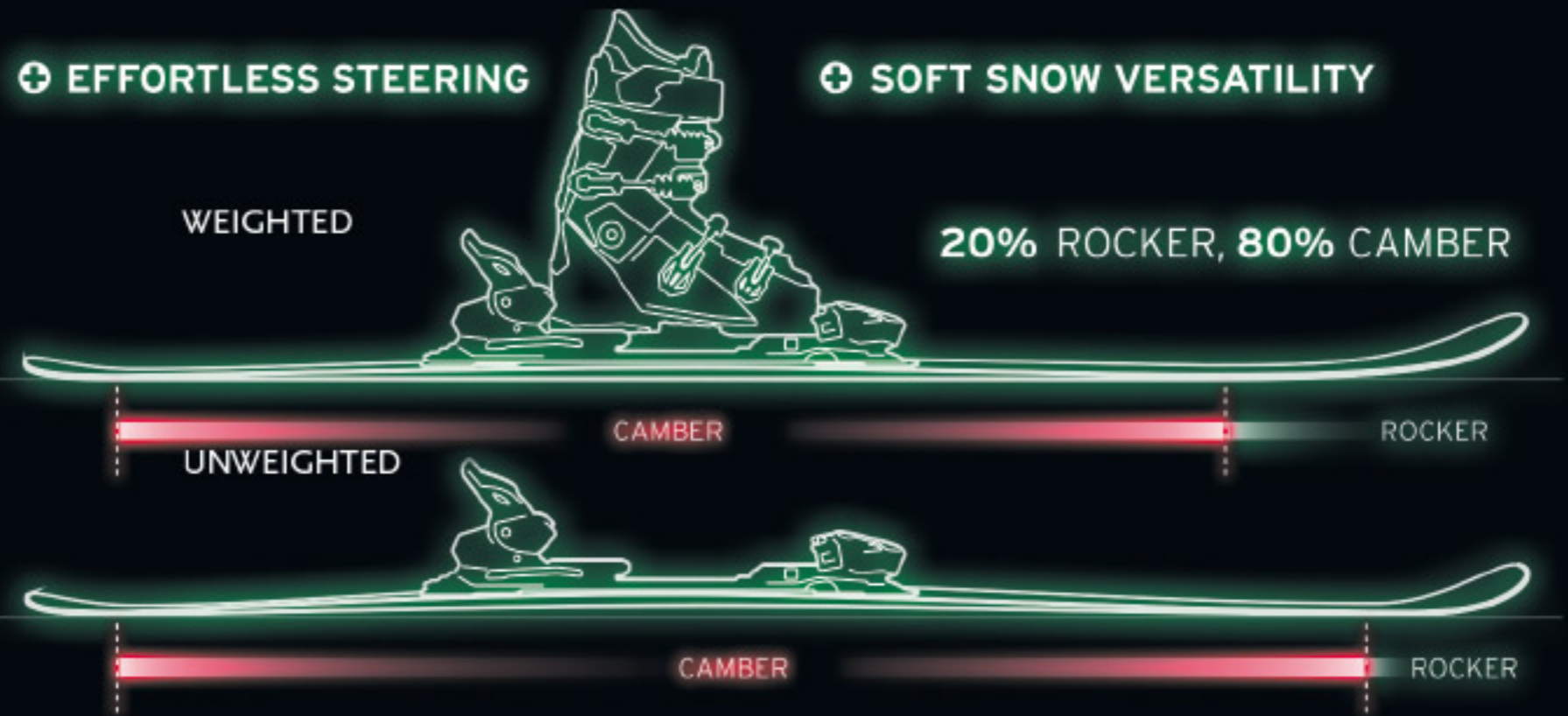

ALLRIDE ROCKER

For superior steering and increased floatation. We place a highly targeted amount of rocker in each model to ensure maximum performance for all ability levels. Steering is easier for all skiers and soft snow versatility is enhanced.

PROGRESSIVE RADIUS

For tremendous turning. Regular rocker makes skiers place their ski further on edge to have it touch from tip-to-tail. With progressive radius, up to 50 % less angulation is needed to enjoy full edge contact. More edge on the snow = more edge grip.

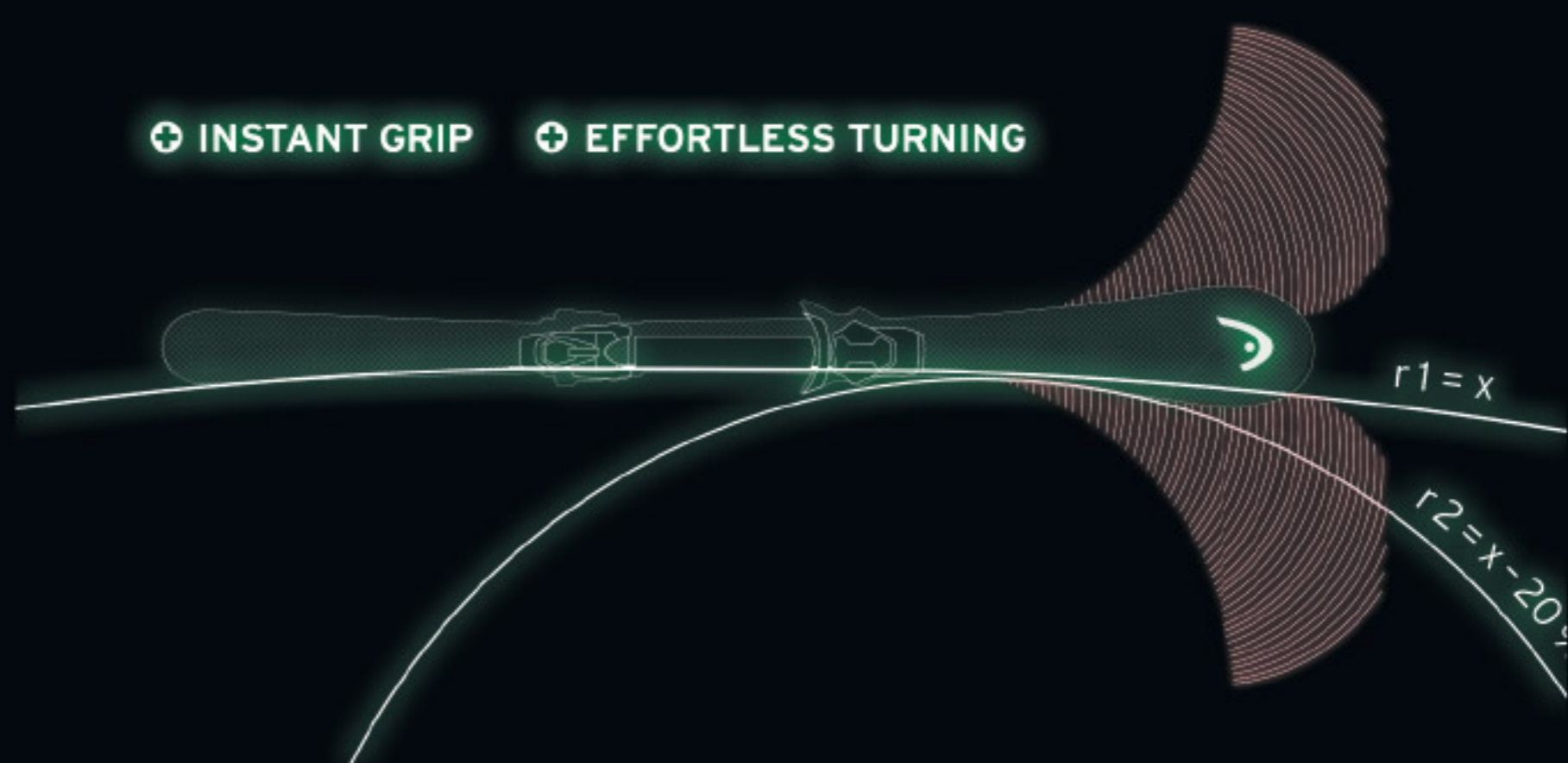

INTELLIRISE REBOUND

For targeted stability. We move our legendary piezoelectric Intellifibers to the tip of the ski. The nasty tip vibrations found on regular rockers are not found here. These skis are too smart for that.



ERA 2.0

THE LITTLE BROTHER OF ERA 3.0. It is everything ERA 3.0 has to offer as far as design, performance and geometry integration,

but without the addition of “Rebound” with its piezoelectric Intellifibers. While we do want to see kids experience skiing performance at the

highest level, they should have the best possible tools to learn and perform.



REV 80 R



ART. N. 312004 FLAT
ART. N. 312024 PR

FEATURES

- Era 3.0
- Wood Core Cap Construction
- ABS sidewalls
- Brushed top sheet
- Black UHM C Base

LENGTHS

142 / 149 / 156 / 163 /
170 / 177

DIMENSIONS

129 / 80 / 111
@ length 170

RADIUS

13,7 @ length 170

REV 78 R



ART. N. 312044 FLAT
ART. N. 312064 PR

FEATURES

- Era 3.0
- Power Sidewall Jacket
- Structured UHM C base

LENGTHS

142 / 149 / 156 / 163 /
170 / 177

DIMENSIONS

127 / 78 / 110 @ length 170

RADIUS

13,6 @ length 170

REV 75 R



ART. N. 312084 FLAT
ART. N. 312094 TRACK
ART. N. 312104 PR

FEATURES

- Era 3.0
- Wood Composite Core
- LizzardSkin top sheet
- Black UHM C base

LENGTHS

142 / 149 / 156 / 163 /
170 / 177

DIMENSIONS

125 / 75 / 109 @ length 170

RADIUS

13,5 @ length 170

REV 70 R



ART. N. 312124 FLAT
ART. N. 312134 TRACK

FEATURES

- Era 3.0
- Synthetic core construction
- SnakeSkin top sheet
- Black UHM C base

LENGTHS

130 / 142 / 149 / 156 / 163 /
170 / 177

DIMENSIONS

123 / 70 / 106 @ length 170

RADIUS

12,8 @ length 170

SHAPE 3.0 R



ART.N°: 312254 TRACK

FEATURES

- Era 3.0
- LizzardSkin top sheet
- Synthetic core construction
- SnakeSkin top sheet
- Black UHM C base

LENGTHS

142 / 149 / 156 / 163 / 170

DIMENSIONS

125 / 70 / 109 @ length 170

RADIUS

12.8 @ length 170

THE LINK PRO R



ART. N. 312433 FLAT
ART. N. 312443 TRACK
ART. N. 312063 TRACK PRE DRILLED
ART. N. 312453 BLACK
ART. N. 312463 YELLOW

FEATURES

- Early rise
- Composite radius construction
- SnakeSkin top sheet
- Woodcore
- Torsion box
- Cap construction

LENGTHS

130 (XS) / 140 (S) / 150 (M) /
160 (L) / 170 (XL)

DIMENSIONS

125 / 69 / 106 @ length 150

RADIUS

10,0 @ length 150

COLOR CODES



THE LINK R



ART. N. 312803 FLAT
ART. N. 312813 TRACK
ART. N. 312823 BLACK
ART. N. 312833 YELLOW

FEATURES

- Early rise
- Composite radius construction
- SnakeSkin top sheet
- Synthetic core construction

LENGTHS

130 (XS) / 142 (S) / 149 (M) /
163 (L) / 170 (XL)

DIMENSIONS

123 / 70 / 106 @ length 170
123 / 68 / 104 @ length 170

RADIUS

12,8 @ length 170

7,1 @ length 170

COLOR CODES



RESIDUE R TRACK



ART. N. 312564 TRACK

FEATURES

- Heavy duty twin tip model
- Mesh top sheet
- Heavy duty woodcore
- UHM C base
- Pre-mounted rental track

LENGTHS

118/127/136/145/154/163/172/181

DIMENSIONS

112/79/106 @ length 172

109/77/103 @ length 145

RADIUS

19,4 @ length 172

13,4 @ length 145

LIGHT JOY R SLR



ART. N. 312504 SLR

FEATURES

- Era 3.0
- Power Fiber Jacket
- Lizard Skin Surface
- Black UHM C base

LENGTHS

143/146/153/163

DIMENSIONS

127/73/107 @ length 158

RADIUS

10,9 @ length 158

SOUPHEAD LR



ART.N: 312704 TRACK
ART.N: 312714 LR

FEATURES

- Twintip construction
 - E base black
- Structured surface
- Also available without LiteRail

LENGTHS

87 / 97 / 107 / 117 / 127 / 137

DIMENSIONS

104 / 68 / 92 @ length 127

RADIUS

9,4 @ length 127

SUPERSHAPE TEAM R



ART.N°: 312664 TRACK 4.5
ART.N°: 312674 TRACK 7.5
ART.N°: 312604 BLUE
ART.N°: 312614 BLACK
ART.N°: 312624 YELLOW
ART.N°: 312634 SILVER
ART.N°: 312644 RED

FEATURES

- Era 2.0
- SnakeSkin top sheet

LENGTHS

67 / 77 / 87 / 107 / 117 / 137

DIMENSIONS

103 / 65 / 89 @ length 87

106 / 66 / 92 @ length 107

111 / 67 / 96 @ length 127

RADIUS

4,0 @ length 87

5,7 @ length 107

8,0 @ length 127

THE ROD



ART.N°: 312993

FEATURES

- SnakeSkin top sheet
 - Full fiber jacket
 - E base black
- Pre-mounted bindings

LENGTHS

94

DIMENSIONS

129 / 90 / 118 @ length 94

RADIUS

4,2 @ length 94

EDGE J3 HT

ART.N°: 608730 RED

FEATURES

Easy Entry shell construction

- Adult norm • 1 sole length
- DIN interface for all rental bindings

LINER

- Junior rental liner
- Tongue handle
- Comfort footbed

BUCKLES

3 plastic buckles

LEVEL

Intermediate

SIZES

235-245-255-265

SHELL

PU/SL

COLOR

Red



CARVE HT 2 B²YS

ART.N°: 607741 RED

FEATURES

Easy Entry shell construction

- Kids' SkiWalk • Junior norm
- 2 sole lengths • DIN interface for all rental bindings

LINER

- Junior rental liner
- Comfort footbed

BUCKLES

2 plastic buckles

LEVEL

Beginner

SIZES

195-205-215-225

SHELL

PU/SL

COLOR

Red

CARVE HT 1 B²YS

ART.N°: 607746 RED

FEATURES

Easy Entry shell construction • Kids'

- SkiWalk • Junior norm sole lengths
- DIN interface for all rental bindings

LINER

- Junior rental liner
- Comfort footbed

BUCKLES

1 plastic buckle

LEVEL

Beginner

SIZES

155-165-175-185

SHELL

PU/SL

COLOR

Red





NEXT EDGE BYS 80 HT

ART.N°: 604717 BLACK / WHITE

FEATURES

- Tri-Inj. energy frame
- Easy entry shell design
- Double canting
- 2 sole lengths

LINER

- Comfort liner
- Sanitized® charcoal footbed
- 40 mm velcro strap

BUCKLES

- 4 micro-adjustable plastic buckles
- 1 Supermacro ratchet

LEVEL

Intermediate

FLEX INDEX

80

SIZES

235-245... Woman constr.
250-255...305 Man constr.

SHELL

PU/SL

LAST

C 2100cc

LAST	100	102	104
SIZE	25,5	26,5	27,5

COLOR

Black/White

EZON 2 BYS

ART.N°: 604740 SILVER, YELLOW, BLACK

FEATURES

3 sole lengths • DIN interface for all rental bindings

LINER

Comfort liner • Sanitized® charcoal footbed
• Prepared for heating system • 35 mm velcro strap

BUCKLES

4 plastic buckles • 1 Supermacro ratchet

LEVEL

Intermediate

SIZES

235-245-...-265 Women's constr.
270-275-...-340 Unisex constr.

SHELL

PU/SL

COLORS

Silver, Yellow, Black



BYS

ART.N°: 604741 SILVER, YELLOW, BLACK

FEATURES

3 sole lengths • DIN interface for all rental bindings

LINER

Comfort liner • Sanitized® charcoal footbed
• Prepared for heating system

BUCKLES

3 plastic buckles • 1 Supermacro ratchet

LEVEL

Beginner

SIZES

235-245-...-295-305-310-320-330-340

SHELL

PU/SL

COLORS

Silver, Yellow, Black



TYROLIA BYS 10

ART.N°: 111575 TYROLIA BYS 10 BRAKE 78 [D] SOLID BLACK/ANTHRACITE

FEATURES

SX toe with TRP system • Full diagonal • ABS – Anti Blocking System • Rent heel • Solid colored

STAND HEIGHT

21,0 mm

DIN

2.5 – 10

WEIGHT

1890 g



WEIGHT RANGE

From 26 kg / from 57 lbs

COLOR

Solid Black/Anthracite

TYROLIA BYS 7.5

ART.N°: 111678 TYROLIA BYS 7.5 AC BRAKE 78 [D] SOLID BLACK

FEATURES

SX Junior toe with TRP system • Full diagonal • SX Junior heel • Solid colored • AFS Junior

STAND HEIGHT

21,0 mm

DIN

2 – 7.5

WEIGHT

1830 g



WEIGHT RANGE

From 22 – 84 kg / from 48 – 187 lbs

COLOR

Solid Black

TYROLIA B²YS 4.5 AC

ART.N°: 111577 TYROLIA B²YS 4.5 AC BRAKE 74 [K] SOLID BLACK

FEATURES

SX Kid toe with TRP system • Full diagonal • AFS Junior • SX Kid heel • Solid colored

STAND HEIGHT

21,0 mm

DIN

0.75 – 4.5

WEIGHT

1195 g



WEIGHT RANGE

From 10 – 48 kg / from 22 – 105 lbs

COLOR

Solid Black

TYROLIA SP 130 ABS

ART.N°: 111447 TYROLIA SP 130 ABS BRAKE 78 [D] WHITE/BLACK

FEATURES

AERO One Touch Toe with TRP system • Race Diagonal • ABS – Anti Blocking System • Rent One Touch heel • Dura-Coating stand height

STAND HEIGHT

31,0 mm

DIN

4 – 13



WEIGHT

2770 g

WEIGHT RANGE

From 42 kg / from 92 lbs

COLOR

White/Black

TYROLIA SP 12 ABS

ART.N°: 111563 TYROLIA SP 12 ABS BRAKE 97 [D] SOLID BLACK/ANTHRACITE

ART.N°: 111564 TYROLIA SP 12 ABS W/O BRAKE [D] SOLID BLACK/ANTHRACITE

FEATURES

LX One Touch Toe with TRP system • Full Diagonal • ABS – Anti Blocking System • Rent One Touch heel • Dura-Coating • Wide brake 97

STAND HEIGHT

31,0 mm

DIN

4 – 12

WEIGHT

2600 g

WEIGHT RANGE

From 42 kg / from 92 lbs

COLOR

Solid Black/Anthracite



TYROLIA SP 10 ABS

ART.N°: 111565 TYROLIA SP 10 ABS BRAKE 78 [D] SOLID BLACK/ANTHRACITE

ART.N°: 111566 TYROLIA SP 10 ABS W/O BRAKE [D] SOLID BLACK/ANTHRACITE

ART.N°: 111567 TYROLIA SP 10 ABS PM SOLID BLACK/ANTHRACITE

FEATURES

SX One Touch Toe with TRP system • Full Diagonal • ABS – Anti Blocking System • Rent One Touch heel • Solid colored

STAND HEIGHT

31,0 mm

DIN

2.5 – 10

WEIGHT

2570 g

WEIGHT RANGE

From 26 kg / from 57 lbs

COLOR

Solid Black/Anthracite



TYROLIA SP 7.5 AC

ART.N°: 111670 TYROLIA SP 7.5 AC PM SOLID BLACK/ANTHRACITE

ART.N°: 111671 TYROLIA SP 7.5 AC BRAKE 78 [D] SOLID BLACK/ANTHRACITE

FEATURES

SX Junior toe with TRP system • Full Diagonal • AFS Junior • SX Junior heel • Solid colored

STAND HEIGHT

31,0 mm

DIN

1.5 – 7.5

WEIGHT

2450 g

WEIGHT RANGE

18 – 84 kg / 39 – 187 lbs

COLOR

Solid Black/Anthracite



TYROLIA SP 4.5 AC

ART.N°: 111571 TYROLIA SP 4.5 AC BRAKE 74 [K] SOLID BLACK

ART.N°: 111572 TYROLIA SP 4.5 AC PM SOLID BLACK

FEATURES

SX Kid One Touch Toe • with TRP system • Full Diagonal • AFS Junior • SX Kid One Touch Heel • Solid colored

STAND HEIGHT

25,0 mm

DIN

0.75 – 4.5

WEIGHT

1630 g

WEIGHT RANGE

10 – 48 kg / 22 – 105 lbs

COLOR

Solid Black



TYROLIA AAATTACK 13 DEMO PM

ART.N°: 111765 TYROLIA AAATTACK
13 DEMO PM SOLID BLACK/WHITE

FEATURES

- FR Pro Toe
- AFD Metal
- RACE One Touch Heel
- Sympro Heel Track
- Solid colored (pm = pre mounted) -> Needs Trackset

STAND HEIGHT

23 mm

DIN

4-13



WEIGHT

2250g (with brake: 2550g)

WEIGHT RANGE

From 42 kg / from 92 lbs

COLOR

Solid Black/White

TYROLIA PR 11

ART.N°: 111733 TYROLIA PR 11 BRAKE
78 [G] SOLID BLACK/SILVER

ART.N°: 111739 TYROLIA PR 11 BRAKE
90 [G] SOLID BLACK/SILVER

FEATURES

- SX Toe with TRP System
- Full Diagonal
- AFS
- PowerRail
- SX Heel
- Solid colored

STAND HEIGHT

31,0 mm

DIN

3-11



WEIGHT

1770 g

WEIGHT RANGE

from 26 kg / from 57 lbs

COLOR

Solid Black/Silver

TYROLIA SR 4.5 AC

ART.N°: 111574 TYROLIA SR 4.5
AC BRAKE 74 [K] SOLID BLACK

FEATURES

- SX Kid Toe with TRP System
- Full Diagonal
- AFS Junior
- SX Kid One Touch Heel
- Length Adjustment: 52 mm
- Boot length: 199 - 255 mm (spare part 231 - 287 mm)
- Solid colored

STAND HEIGHT

15,0mm

DIN

0.75 - 4.5



WEIGHT

1210 g

WEIGHT RANGE

10 - 48 kg / 22 - 105 lbs

COLOR

Solid Black

TYROLIA SR 10

ART.N°: 111573 TYROLIA SR 10 BRAKE
78 [D] SOLID BLACK/ANTHRACITE

FEATURES

- SX Toe with TRP system
- Full Diagonal
- Teflon
- Rent One
- Touch heel
- Solid colored

STAND HEIGHT

22,0mm

DIN

2.5 - 10

WEIGHT

2145 g



WEIGHT RANGE

From 26 kg / from 57 lbs

COLOR

Solid Black/Anthracite

TYROLIA LRX 9.0

ART.N°: 111527 TYROLIA LRX 9.0
BRAKE 78 [H] SOLID BLACK/SILVER

FEATURES

- SX Toe with TRP system
- Full Diagonal
- ABS - Anti Blocking System
- LiteRail
- SL Lite heel
- Solid colored

STAND HEIGHT

28,0mm

DIN

2.5 - 9

WEIGHT

1600g



WEIGHT RANGE

From 26 kg / from 57 lbs

COLOR

Solid Black/Silver

TYROLIA LRX 7.5

ART.N°: 111535 TYROLIA LRX 7.5
AC BRAKE 78 [H] SOLID BLACK/SILVER

FEATURES

- SX Junior Toe with TRP system
- Full Diagonal
- AFS Junior
- LiteRail
- SX Junior heel
- Solid colored

STAND HEIGHT

28,0mm

DIN

2 - 7.5

WEIGHT

1380g



WEIGHT RANGE

22 - 84 kg / 48 - 187 lbs

COLOR

Solid Black/Silver



ADULT RENTAL

ART.N°: 381421 COLOR CODED BY LENGTH

FEATURES

- 7075 Aluminum
- PE grip
- Color coded design
- Color coded baskets
- Length indication cm / inch
- Steel tip

DIAMETER Ø

18x1 mm

LENGTHS

110 – 135 cm

COLOR

Color coded by length

ADULT RENTAL SUBLIMATED

ART.N°: 381421 COLOR CODED BY LENGTH

FEATURES

- 7075 Aluminum
- PE grip
- Color coded design
- Color coded baskets
- Thermo sublimated finish
- Length indication cm / inch
- Steel tip

DIAMETER Ø

18x1 mm

LENGTHS

110 – 135 cm

COLOR

Color coded by length

JUNIOR RENTAL

ART.N°: 381411 COLOR CODED BY LENGTH

FEATURES

- 7075 Aluminum
- Junior PE grip
- Color coded design
- Color coded baskets
- Length indication cm / inch
- Steel tip

DIAMETER Ø

16x0,8 mm

LENGTHS

70 – 105 cm

COLOR

Color coded by length



JUNIOR RENTAL SUBLIMATED

ART.N°: 381412 COLOR CODED BY LENGTH

FEATURES

- 7075 Aluminum
- Junior PE grip
- Color coded design
- Color coded baskets
- Thermo sublimated finish
- Length indication cm / inch
- Steel tip

DIAMETER Ø

16x0,8 mm

LENGTHS

70 – 105 cm

COLOR

Color coded by length



VECTOR 115 HT

ART.N°: 604702 TRSP. YELLOW/BLACK

FEATURES

- Bi-Inj frame
- Easy Entry shell design
- Flex tuning
- Double canting
- Rear support tuning

LINER

- Perfect Fit S liner
- HP frame footbed
- 40mm velcro strap
- Sanitized® charcoal footbed

BUCKLES

- 4 micro-adjustable alloy buckles
- 1 Supermacro ratchet

LEVEL

Expert

FLEX INDEX

115/105

SIZES

250-255...-305

SHELL

PU

LAST

S 2000cc

LAST	99	101	103
SIZE	25.5	26.5	27.5

COLOR

Trsp. Yellow/Black

ADAPT EDGE 100 HT

ART.N°: 604703 TRSP. ANTHR.-BLACK

FEATURES

Tri-Inj. energy frame • Adaptive Fit Technology • Easy Entry shell design • Stiffer / softer flex adjustment • Double canting • Adjustable rear spoiler

LINER

Comfort liner • Sport frame footbed • 40mm velcro strap • Sanitized® charcoal footbed

BUCKLES

- 4 micro-adjustable alloy buckles
- 2 Double Power levers
- 1 Supermacro ratchet

LEVEL

Advanced

FLEX INDEX

100/90

SIZES

270-275...-320 Unisex constr.

SHELL

PU

LAST

C 2100cc

LAST	100-98	102-100	104-102
SIZE	25.5	26.5	27.5

COLOR

Trsp. Anthr.-/Black



ADAPT EDGE 100 HT W

ART.N°: 604704 TRSP. ANTHR.-BLACK (WOMAN)

FEATURES

Tri-Inj. energy frame • Adaptive Fit Technology • Easy Entry shell design • Stiffer / softer flex adjustment • Double canting • Adjustable rear spoiler

LINER

Comfort liner • Sport frame footbed • 40mm velcro strap • Sanitized® charcoal footbed

BUCKLES

- 4 micro-adjustable alloy buckles
- 2 Double Power levers
- 1 Supermacro ratchet

LEVEL

Advanced

FLEX INDEX

100/90

SIZES

230-235...-265 Women's constr.

SHELL

PU

LAST

C 2100cc

LAST	100-98	102-100	104-102
SIZE	25.5	26.5	27.5

COLOR

Trsp. Anthr.-/Black





NEXT EDGE 90 HT

ART.N°: 604707 TRSP. RED/WHITE

FEATURES

- Tri-Inj. energy frame • Easy Entry shell design • Stiffer / softer flex adjustment • Double canting
- Man extra: Adjustable rear spoiler

LINER

- Comfort liner • Sanitized® charcoal footbed • 40 mm velcro strap

BUCKLES

- 4 micro-adjustable alloy buckles
- 2 Double Power levers
- 1 Supermacro ratchet

LEVEL

Advanced

FLEX INDEX

90/80

SIZES

250-260-265-...-305 Male constr.
250-255-260-265-...-305 Unisex constr.

SHELL

PU

LAST

S 2100cc

LAST	100	102	104
SIZE	25.5	26.5	27.5

COLOR

Trsp. Red/White

NEXT EDGE 90 HT W

ART.N°: 604708 TRSP. ANTHR. /WHITE

FEATURES

Tri-Inj. energy frame • Easy Entry shell design • Stiffer / softer flex adjustment • Double canting

- Woman extra: Double adjustable profile

LINER

- Women's comfort liner
- Fleece lining
- Sanitized® charcoal footbed
- 30 mm velcro strap

BUCKLES

- 4 micro-adjustable alloy buckles
- 2 Double Power levers
- 1 Supermacro ratchet

LEVEL

Advanced

FLEX INDEX

80/70

SIZES

220-225-230-235-...-275

SHELL

PU

LAST

S 2100cc

LAST	100	102	104
SIZE	25.5	26.5	27.5

COLOR

Trsp. Anthr./White



NEXT EDGE 80 HT / W

ART.N°: 604715 BLACK/WHITE
ART.N°: 604716 WHITE/VIOLET (WOMAN)

FEATURES

Tri-Inj. energy frame • Easy Entry shell design • Double canting • Woman extra: Double adjustable profile

LINER

Woman liner: Women's comfort liner • Fleece lining • Sanitized® charcoal footbed • 30 mm velcro strap
Male liner: Comfort liner • Sanitized® charcoal footbed • 40 mm velcro strap

BUCKLES

- 4 micro-adjustable alloy buckles
- 1 Supermacro ratchet

LEVEL

Advanced

FLEX INDEX

Unisex: 80 / Woman: 70

SIZES

250-255-260-265-...-305-310-320-330-340 Unisex constr.
220-225-230-235-...-275 Women's constr.

SHELL

PU / SL

LAST

C 2100cc

LAST	100	102	104
SIZE	25.5	26.5	27.5

COLORS

Black/White, White/Violet



FX 7.5 HT

ART.N°: 604721 BLACK

FEATURES

Power control frame

LINER

Comfort liner • Sanitized® charcoal footbed • 35 mm velcro strap

BUCKLES

- 4 plastic buckles
- 1 Supermacro ratchet

LEVEL

Intermediate

FLEX INDEX

60

SIZES

260-265-...-305 Man constr.

230-235-...-255 Woman constr.

SHELL

PU/SL

LAST

EC 2200cc

LAST	102	104	106
SIZE	25,5	26,5	27,5

COLOR

Black

CUBE3 8 HT

ART.N°: 604730 BLACK

FEATURES

- Power control frame
- Integrated AutoSkiWalk

LINER

Comfort quick entry liner • Sanitized® charcoal footbed • 35 mm velcro strap

BUCKLES

- 2 micro-adjustable plastic buckles
- 1 micro-adjustable wide-body alloy buckle • 1 Supermacro ratchet

LEVEL

Intermediate

FLEX INDEX

70

SIZES

260-265-...-305 Unisex constr.

SHELL

PU/SL

LAST

EC 2200cc

LAST	102	104	106
SIZE	25,5	26,5	27,5

COLOR

Black



CUBE3 8 HT W

ART.N°: 604731 BLACK (WOMAN)

FEATURES

- Power control frame
- Integrated AutoSkiWalk

LINER

Comfort quick entry liner • Sanitized® charcoal footbed • 35 mm velcro strap

BUCKLES

- 2 micro-adjustable plastic buckles
- 1 micro-adjustable wide-body alloy buckle • 1 Supermacro ratchet

LEVEL

Intermediate

FLEX INDEX

70

SIZES

230-235-...-255 Woman constr.

SHELL

PU/SL

LAST

EC 2200cc

LAST	102	104	106
SIZE	25,5	26,5	27,5

COLOR

Black





RR8

ART. N. 602770 BLACK/WHITE

FEATURES

Rear entry

LINER

- Comfort rear entry liner
- Sanitized® charcoal footbed

BUCKLES

1 plastic buckle

LEVEL

Beginner

SIZES

235-...-305

SHELL

PU/SL

COLOR

Black/White

RAPTOR 50 HT

ART.N°: 603755 BLACK/WHITE

FEATURES

- Jr Racing flex tuning
- Adult norm (rom size 220 up)

LINER

- Junior Team liner
- Self-shaping footbed

BUCKLES

4 plastic buckles

LEVEL

Advanced

SIZES

200-210-220-...-265

SHELL

PU / SL

COLOR

Black/White



RAPTOR 40 HT

ART.N°: 603756 BLACK/WHITE

FEATURES

- Jr Racing flex tuning
- Adult norm

LINER

- Junior Team liner
- Self-shaping footbed

BUCKLES

3 plastic buckles

LEVEL

Advanced

SIZES

185-190-...-245

SHELL

PU / SL

COLOR

Black/White



HEAD LAUNCHES

A NEW HELMET TECHNOLOGY

BY USING A
REVOLUTIONARY
IMPACT ABSORBING
MATERIAL.



INNOVATIVE

This is the start of a new era in helmet construction: SOFT CORE. The innovative DELTACELL TECHNOLOGY builds the core of the helmet, increasing comfort & fit, and hence safety.

SAFETY

The best helmet is the one you don't even feel it's on your head. The soft DELTACELL TECHNOLOGY adapts perfectly to the head, creating a snug fit for increased safety.

COMFORT

The soft DELTACELL TECHNOLOGY with its characteristic pattern adapts itself to the wearers head individually, avoiding pressure points. This makes the A|SERIES outstanding in terms of comfort.

AIRFLOW

DELTA CELL has an open structure. This enables a constant airflow for a comfortable helmet climate.



1 Original shape



2 Adapts to head form



3 Original shape

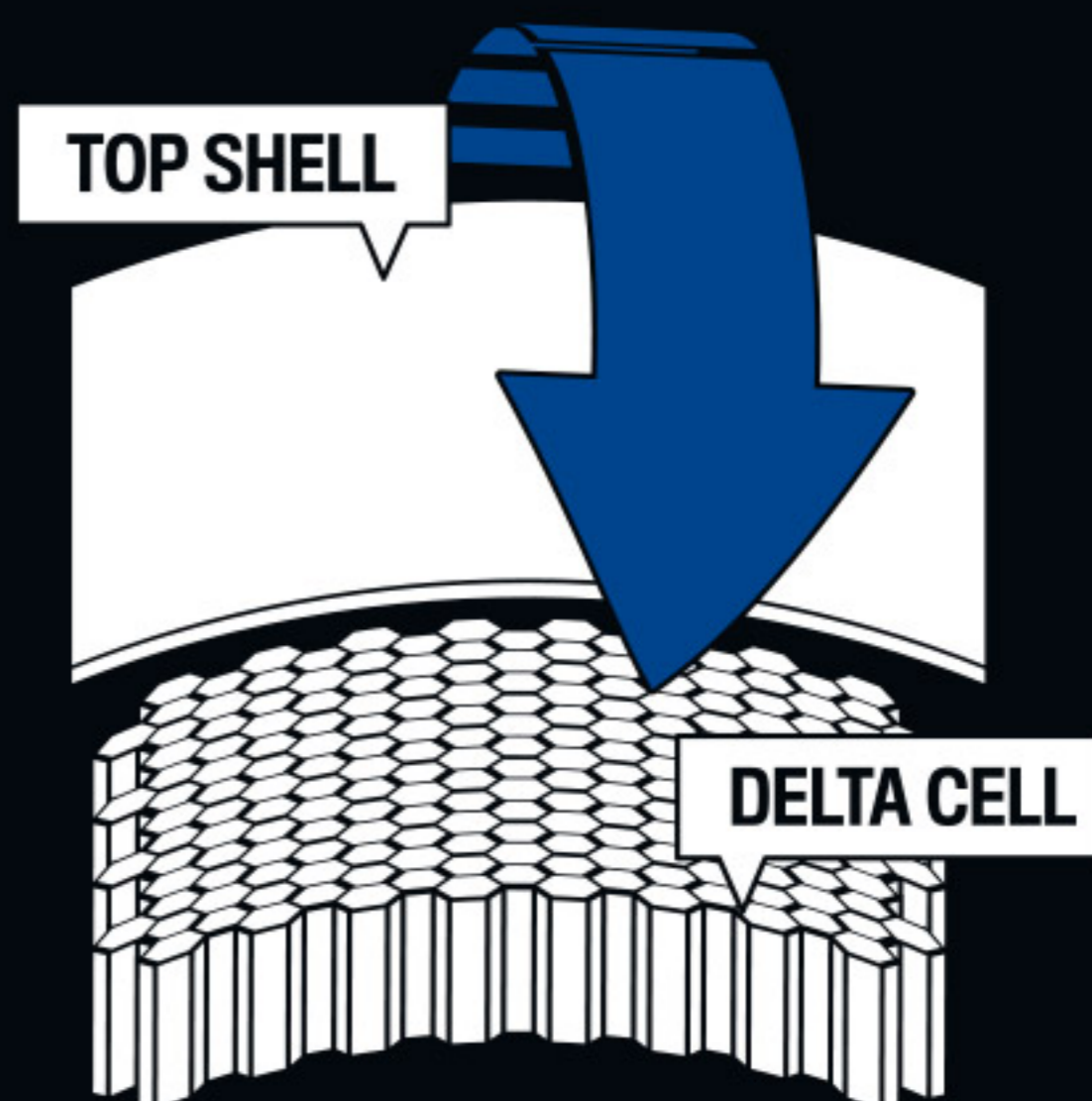

SD+D

SANITIZE. DOCK & DRY

THE FIRST
FULLY-INTEGRATED
RENTAL HELMET CONCEPT

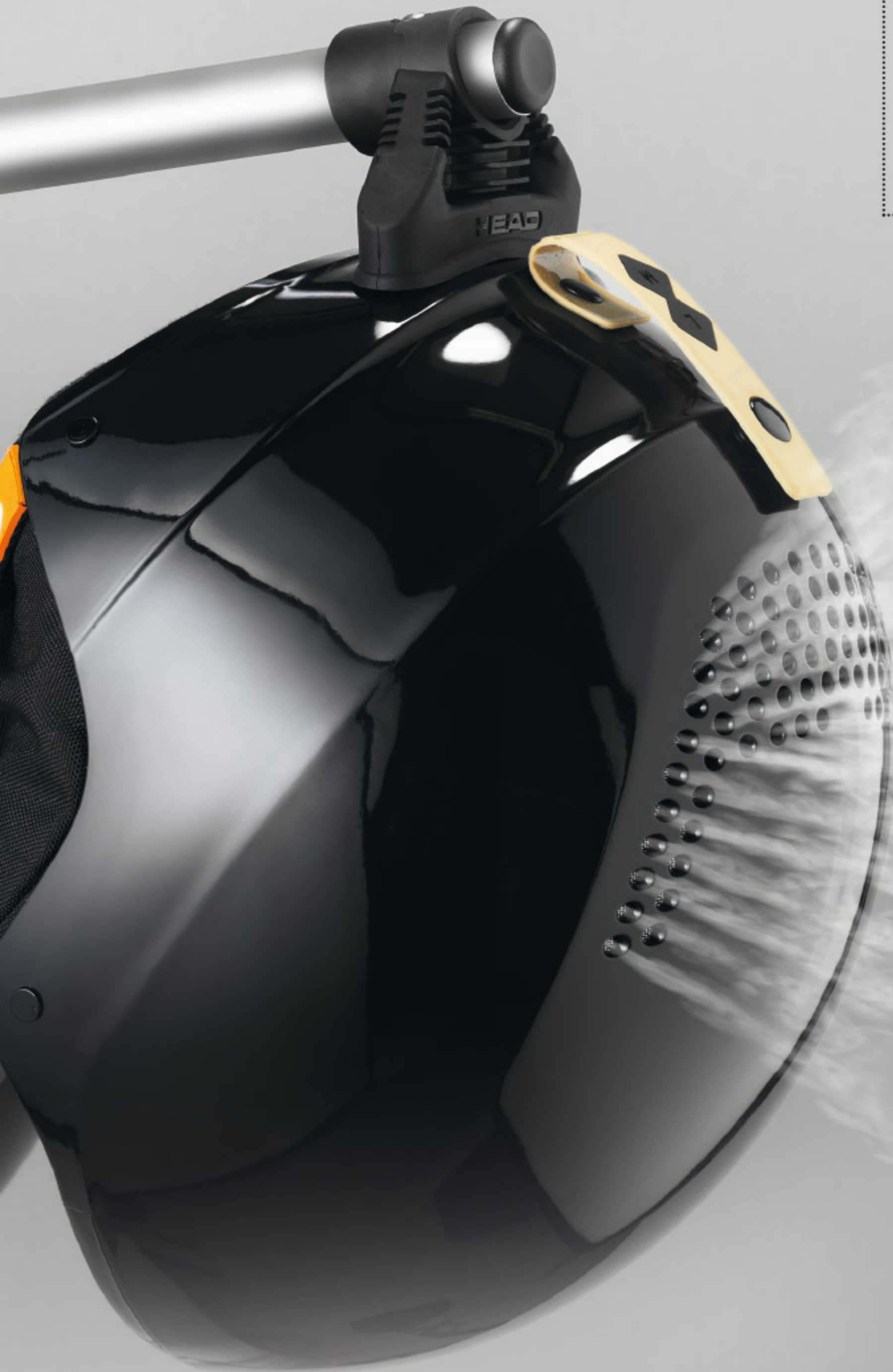

SANITIZE

From rapid drying to complete disinfection of the helmet. The optional integration of the IONIZATION TUBE prevents development of odors and kills germs and bacteria. HEAD SANITIZER guarantees optimal helmet disinfection – quickly and efficiently.

DOCK

The Head SD+D system provides space for up to 108 SD+D helmets per m² of floor space. The modular construction enables optimal adaptation to the individual space and quantity requirements of every client. Extension to the system – from the simple storage solution to the fully-integrated & ventilated HELMET DRYING RACK, is possible at any time.



DRY

Via AIRDOCKS warm air is directed inside of the helmet. The result: minimal drying time for the operator and pleasantly warm helmets for the rental customer. The helmets are stored according to a logical and individually ordered system. Magnetic AIRDOCKS keep the helmets safely in position – this ensures easy and direct access.

ALL HELMETS OF THE HEAD VENTOR RANGE
ARE COMPATIBLE WITH THE SD+D SYSTEM.

HELMET STORAGE RACK

HEAD has the solution for efficient storage of helmets: the HELMET STORAGE RACK can be adjusted to the space and quantity requirements of the client and provides both space and easy access for up to 324 helmets on a floor space of 3 m².

HELMET STORAGE RACK 150

ART.N°: 375502 for 180 helmets

HELMET STORAGE RACK 200

ART.N°: 375512 for 252 helmets

HELMET STORAGE RACK 240

ART.N°: 375522 for 324 helmets

HELMET DRYING RACK

In addition to the advantages of the HELMET STORAGE RACK, the HELMET DRYING RACK guarantees rapid and effective drying of the helmets via an integrated drying module. Warm air is directed inside the helmet via the AIRDOCKs and dries the helmets from the inside out, thus reducing drying time to a minimum. The optional ionization tube integrated directly into the air intake also prevents development of odor in the helmets. Both the HELMET STORAGE RACK and the HELMET DRYING RACK are available in widths of 150 cm, 200 cm and 240 cm as free-standing racks on legs. Existing track systems of the brand MONTANA can be integrated if required.

HELMET DRYING RACK 150

ART.N°: 375532 for 180 helmets

HELMET DRYING RACK 200

ART.N°: 375542 for 252 helmets

HELMET DRYING RACK 240

ART.N°: 375552 for 324 helmets

HELMET WALLDRYER 100

ART.N°: 375572

The helmet WALLDRYER 100 completes the portfolio of the SD + D system; it can hold 60 helmets on only one meter or three feet of wall space. Helmets attached to the system can be automatically dried during storage. Standard household power supply can be used to operate the unit on 220 V or 110 V. This not only makes the smallest version of a full-feature SD + D system an easy step into the system, but it also fulfills the needs of smaller operations. The SD + D HELMET WALLDRYER 100 racks can be used free standing or standing against a wall.



RENTAL INTERFACE

ART.N°: 375412

The starting point for the modular HEAD SD+D system. An interface offers space for space-saving and efficient storage of 3 helmets and can be used together with the FLIP CLIP RAIL, HELMET STORAGE & DRYING RACK, and HELMET WALLDRYER.



FLIP CLIP RAIL

ART.N°: 375442 1 METER
ART.N°: 375452 2 METER

Tracks for the simple and individual assembly of the RENTAL INTERFACE. In the 1- or 2-meter version, the FLIP CLIP RAIL offers space for 3 OR 6 RENTAL INTERFACES.

LENGTH

- 1 meter
- 2 meter



HEAD SANITIZER

ART.N°: 375462

With this easy-to-operate stainless-steel appliance you can disinfect rental shoes and helmets quickly and efficiently. Three spray jets ensure even distribution of the disinfectant over the whole shoe or helmet for controlled sterilization thereby preventing development of odors. The included table ensures an ideal working height and practical storage space.

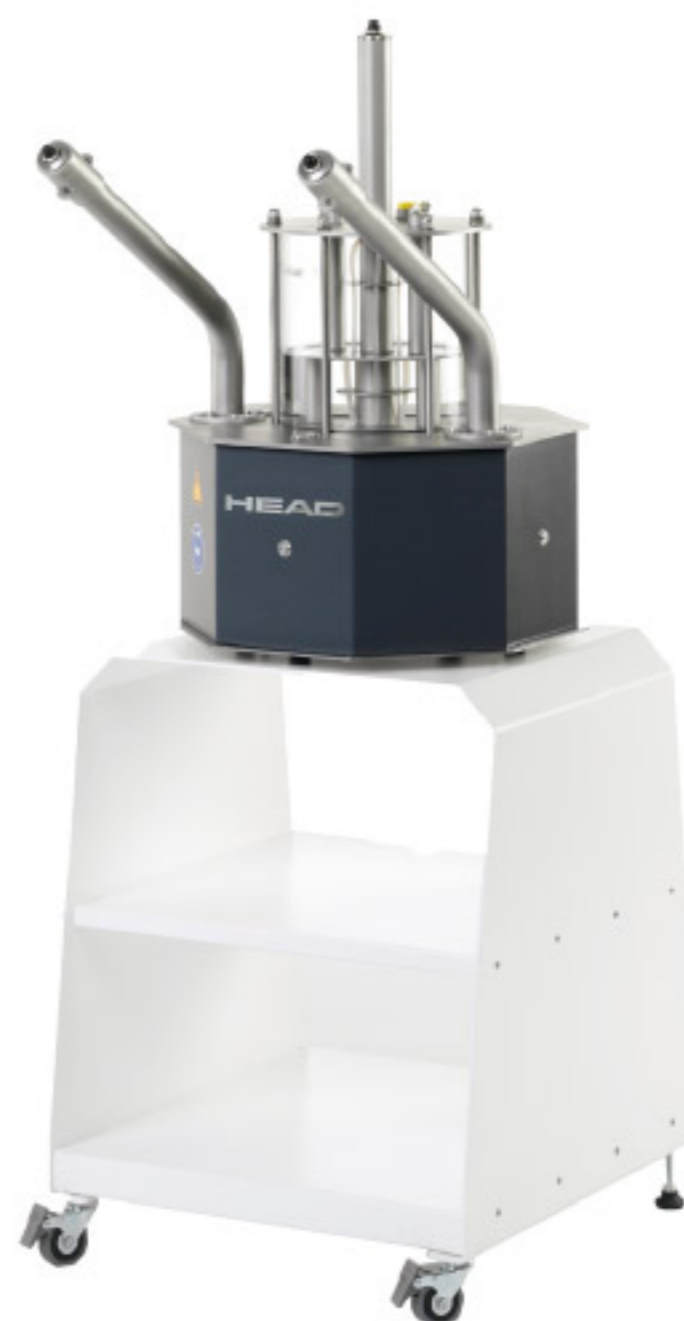

AIR

ART.N°: 329224 BLACK
ART.N°: 329234 CYAN

FEATURES

- SD+D compatible
- LIGHT ABS shell
- DELTACELL core
- THERMAL ventilation
- Agion™
- 2D FIT system
- TPR goggle retainer
- Rental barcode identification
- Color coded

SIZES AND WEIGHTS

XS/S	M/L	XL/XXL
(52-55 cm)	(56-59 cm)	(60-63 cm)
530 g		

COLORS

Black
Cyan



AIR YOUTH

ART.N°: 329604 GREEN
ART.N°: 329614 PINK

FEATURES

- SD+D compatible
- LIGHT ABS shell
- DELTACELL core
- THERMAL ventilation
- Agion™
- 2D FIT system
- TPR goggle retainer
- Rental barcode identification
- Color coded

SIZES AND WEIGHTS

XXS	XS/S	M/L
(49-51 cm)	(52-55 cm)	(56-59 cm)
530 g		

COLORS

Green
Pink



VENTOR PRO R

ART.N°: 329013 LIME/BLUE
ART.N°: 329002 BLACK/WHITE

FEATURES

- SD+D compatible
- ADJUSTABLE ventilation
- Agion™
- 2D FIT system
- TPR goggle retainer
- Rental barcode identification
- Color coded

SIZES AND WEIGHTS

XS/S	M/L	XL/XXL
(52-55 cm)	(56-59 cm)	(60-63 cm)
550 g		

COLORS

Lime/Blue
Black/White



VENTOR R

ART.N°: 329052 BLACK
ART.N°: 329103 WHITE

ART.N°: 329702 WHITE
ART.N°: 329713 LIME

FEATURES

- SD+D compatible
- THERMAL ventilation
- Agion™
- 2D FIT system
- TPR goggle retainer
- Rental barcode identification
- Color coded

SIZES AND WEIGHTS ADULT

XS/S	M/L	XL/XXL
(52-55 cm)	(56-59 cm)	(60-63 cm)
550 g		

SIZES AND WEIGHTS YOUTH

XSS	XS/S	M/L
(49-51 cm)	(52-55 cm)	(56-59 cm)
550 g		

COLORS ADULT

Black
White

COLORS YOUTH

White
Lime



ADULT



YOUTH



RENTAL SR

ART.N°: 329513 BLACK

FEATURES

- THERMAL ventilation
- 2D FIT system
- TPR goggle retainer
- Rental barcode identification
- Color coded

SIZES AND WEIGHTS

XS/S	M/L	XL/XXL
(52-55 cm)	(56-59 cm)	(60-63 cm)
	520 g	

COLOR

Black



RENTAL JR

ART.N°: 329813 WHITE

FEATURES

- THERMAL ventilation
- 2D FIT system
- TPR goggle retainer
- Rental barcode identification
- Color coded

SIZES AND WEIGHTS

XXS	XS/S	M/L
(48-51 cm)	(52-55 cm)	(56-59 cm)
		520 g

COLOR

White



FLEXOR UNIT R SR / JR

ART.N°: 395453 SENIOR
ART.N°: 395463 JUNIOR

FEATURES

- SAS TEC viscoelastic foam
- REMOVABLE protection unit
- 3D mesh
- NYLON fabric
- POLYGIENE

SIZES AND WEIGHTS

XXS – XL/XXL



SENIOR / BACK



SCAN-BARCODE



REMOVABLE PROTECTION UNIT



JUNIOR / BACK



JUNIOR / BACK



SENIOR / BACK

RENTAL BEANIE SR / JR

ART.N°: 375108 RENTAL BEANIE SR
ART.N°: 375208 RENTAL BEANIE JR

FEATURES

Washable & removable beanie liner



HELMET SIZER

ART.N°: 375812 HELMET SIZER

FEATURES

Measure the right HEAD size



2006 WE BROUGHT YOU BYS. 2012 WE BROUGHT YOU SD + D

2014 WE BRING YOU 4D, AND HENCE TAKE SNOWBOARD RENTALS TO THE NEXT DIMENSION.

HEAD BRINGS YOU 4D – PERFECT SETUP, MOST EFFICIENT



We face each of our customers individually, cater to for their perfect setup when renting equipment. Having a positive experience when riding is the key driver to returning customers, no matter what age, gender, ability level or family situation they are – everyone has very own specific needs, which the HEAD 4D system and its wide product portfolio addresses. And

all of that in even less time. If you had to explain the all new 4D system with one word, it would be: Efficiency. But 4D also stands for functionality, reliability and innovation: It is the first snowboard rental system with integrated color coding for boots, boards AND bindings. The all new 4D system manages it to cater for the perfect setup for every single customer of yours, and

at the same time, being the easiest, quickest & most efficient snowboard rental system on the market. Although the benefits of 4D can only be fully exploited by using 4D compatible products, each product can also be used by itself or combined with non-4D products – thanks to its modular structure.

RENTAL SNOWBOARD TECHNOLOGY | FRAMEWALL

FRAMEWALL

The extraordinary stressing of rental snowboards so far resulted in fast abrasion as far as delamination of top sheets. This problem has been solved with the all new FRAMEWALL.

The three-dimensional build of the sidewall covers the boards top sheet and prevents it from chipping and other external hazards, which is resulting in delamination.

The FRAMEWALL is the first 360° protector on a snowboard – that stretches the boards durability considerably!

FRAMEWALL



SIDEWALL

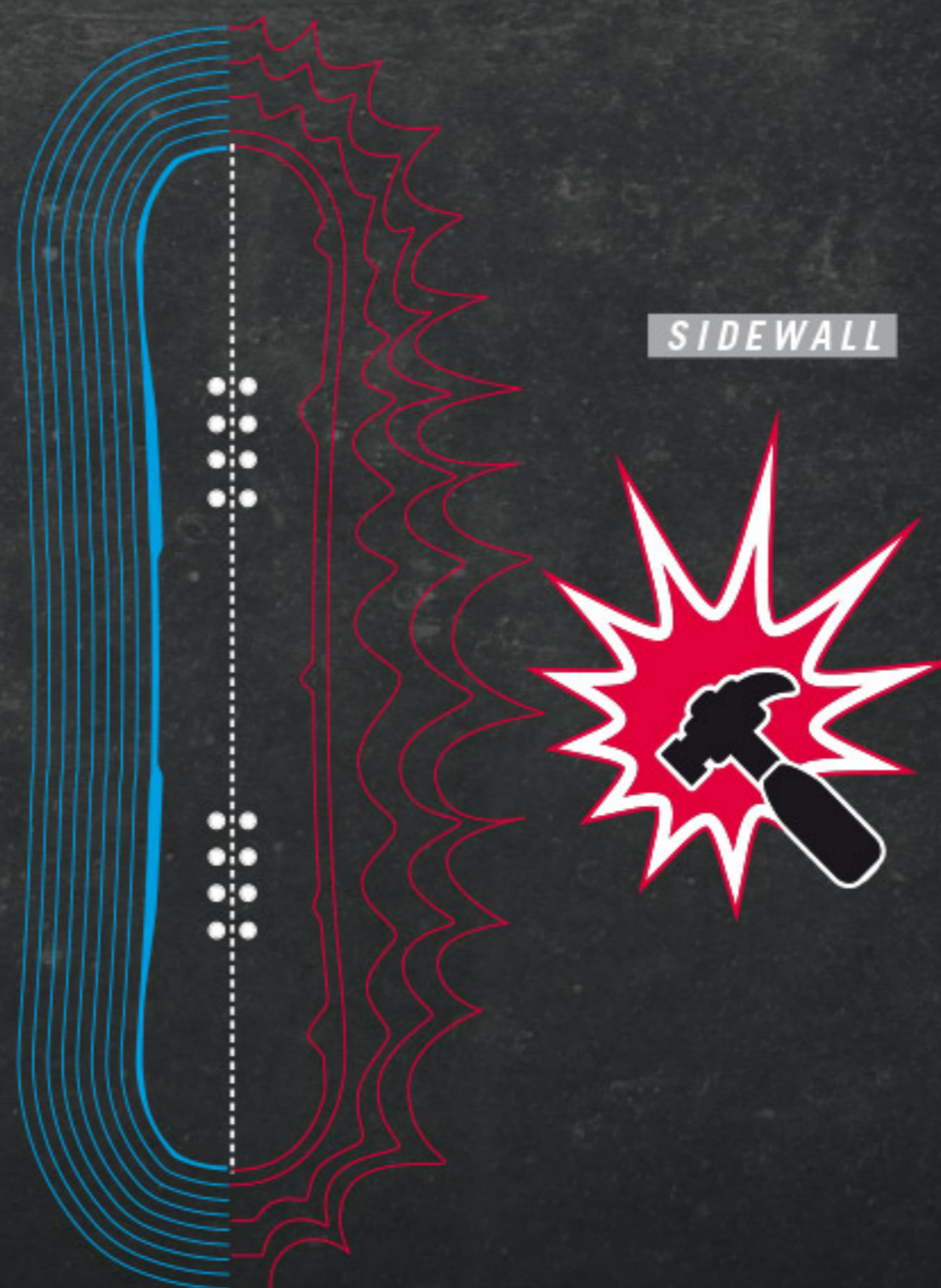

DURABILITY

RUBBER REINFORCEMENTS

SPECIAL BOOT CONSTRUCTION AND RUBBER REINFORCEMENTS, WHERE BOOTS ARE STRESSED MOST.

HEAVY DUTY OUTSOLE

THESE BOOTS ARE MADE FOR WALKING, AND RIDING, AND RENTING.



DURATECH TOESTRAP

EXTRA-DURABLE MATERIAL, SNUG FIT : PERFECT POWER TRANSMISSION.

SPEED DISK RENTAL

ALL OF OUR BINDINGS ARE COMPATABLE TO OUR BOMB PROOF SPEED DISK SYSTEM FOR SUPER QUICK SETUP.



FRAMEWALL

AWARD WINNING SNOWBOARD TECHNOLOGY.

TOPSHEET

EXTREME SITUATIONS CALL FOR EXTREME MEASURES.



EFFICIENCY

MONDO POINT



195-215



225-250



255-280

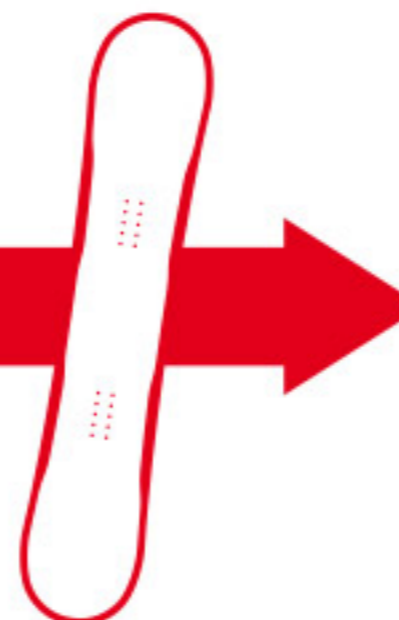

285-325



GO RIDE



FEATURES

- 4D compatible
- Flocka shape
- FRAMEWALL
- Pro-Rent topsheet
- Poplar wood core
- Easy maintenance base

FLOCKA 4D

ART.N°: 337003 FLOCKA 4D
+ SPEEDDISC

ART.N°: 337053 FLOCKA 4D

Sizes	Loaded effective edge (cm)	Waist (mm)	Med. stance (cm)
146	109,0	239	51
151	111,0	244	53
149	110,5	247	52
154	114,5	250	56
159	114,9	254	58
158	114,9	264	58
163	119,9	266	60
168	124,9	268	60

FLOCKA 4D KID

ART.N°: 337203 FLOCKA 4D KID
+ SPEEDDISC

ART.N°: 337253 FLOCKA 4D KID

Sizes	Loaded effective edge (cm)	Waist (mm)	Med. stance (cm)
90	60,0	200	30
100	67,0	210	32
110	75,3	220	36

No FRAMEWALL on FLOCKA 4D KID.

FLOCKA 4D JR

ART.N°: 337103 FLOCKA 4D JR
+ SPEEDDISC

ART.N°: 337153 FLOCKA 4D JR

Sizes	Loaded effective edge (cm)	Waist (mm)	Med. stance (cm)
120	82,6	220	42
130	92,0	230	44
140	101,0	240	46



FEATURES

- 4D compatible
- Rocka shape
- FRAMEWALL
- UVR topsheet
- Poplar wood core
- Easy maintenance die-cut base

ROCKA FW 4D

ART.N°: 337304 ROCKA FW 4D + SPEEDDISC
ART.N°: 337354 ROCKA 4D

Sizes	Loaded effective edge (cm)	Waist (mm)	Med. stance (cm)
146	58	237	50
151	60	243	52
149	60	244	52
154	64	250	56
159	66	253	58
158	66	264	58
163	68	266	60
168	68	268	60

ROCKA FW 4D JR

ART.N°: 337404 ROCKA FW 4D JR + SPEEDDISC
ART.N°: 337454 ROCKA FW 4D JR

Sizes	Loaded effective edge (cm)	Waist (mm)	Med. stance (cm)
120	50	220	42
130	52	230	44
140	54	240	46

ROCKA FW 4D KID

ART.N°: 337504 ROCKA FW 4D KID + SPEEDDISC
ART.N°: 337554 ROCKA FW 4D KID

Sizes	Loaded effective edge (cm)	Waist (mm)	Med. stance (cm)
90	38	200	30
100	40	210	32
110	44	220	36

No FRAMEWALL on ROCKA FW 4D KID.



FEATURES

- 4D compatible
- Rocka shape
- Integral T&T Shield Tip & Tail Protector
- Easy-Rent topsheet
- Poplar wood core
- Easy maintenance base

ROCKA PLUS 4D

ART.N°: 337313 ROCKA PLUS 4D +SPEEDDISC

ART.N°: 337353 ROCKA PLUS 4D

Sizes	Loaded effective edge (cm)	Waist (mm)	Med. stance (cm)
146	58	237	50
151	60	243	52
149	60	244	52
154	64	250	56
159	66	253	58
158	66	264	58
163	68	266	60
168	68	268	60

ROCKA PLUS 4D KID

ART.N°: 337503 ROCKA PLUS 4D KID +SPEEDDISC

ART.N°: 337553 ROCKA PLUS 4D KID

Sizes	Loaded effective edge (cm)	Waist (mm)	Med. stance (cm)
90	38	200	30
100	40	210	32
110	44	220	36

ROCKA PLUS 4D JR

ART.N°: 337403 ROCKA PLUS 4D JR +SPEEDDISC

ART.N°: 337453 ROCKA PLUS 4D JR

Sizes	Loaded effective edge (cm)	Waist (mm)	Med. stance (cm)
120	50	220	42
130	52	230	44
140	54	240	46



FEATURES

- 4D compatible
- Rocka shape
- Exchangeable Tip & Tail bumpers
- Easy-Rent topsheet
- Poplar wood core
- Easy maintenance die-cut base

ROCKA 4D

ART.N°: 337603 ROCKA 4D + SPEEDDISC
ART.N°: 337653 ROCKA 4D

Sizes	Loaded effective edge (cm)	Waist (mm)	Med. stance (cm)
146	58	237	50
151	60	243	52
149	60	244	52
154	64	250	56
159	66	253	58
158	66	264	58
163	68	266	60
168	68	268	60

ROCKA 4D JR

ART.N°: 337703 ROCKA 4D JR + SPEEDDISC
ART.N°: 337753 ROCKA 4D JR

Sizes	Loaded effective edge (cm)	Waist (mm)	Med. stance (cm)
120	50	220	42
130	52	230	44
140	54	240	46

ROCKA 4D KID

ART.N°: 337803 ROCKA 4D KID + SPEEDDISC
ART.N°: 337853 ROCKA 4D KID

Sizes	Loaded effective edge (cm)	Waist (mm)	Med. stance (cm)
90	38	200	30
100	40	210	32
110	44	220	36



RX 4D SPEEDDISC

ART.N°: 347103

FEATURES

- 4D compatible
- Reclining highback
- Rubber dampened base
- Padded highback
- Power transmission strap
- Dura tech toe strap

SIZES

S/M/L

NX 4D SPEEDDISC

ART.N°: 347403

FEATURES

- 4D compatible
- AutoOpen Total
- Toe & heel base pads
- Padded highback
- Toolfree forward lean adjuster
- Power transmission strap
- Dura tech toe strap
- Alu buckles

SIZES

S/M/L



P THREE 4D SPEEDDISC

ART.N°: 347503

FEATURES

- Alu heelcup
- Toe & heel base pads
- Padded highback
- 3D comfort strap
- Dura tech toe strap
- Alu buckles
- 4D compatible

SIZES

S/M/L

P 4D JR SPEEDDISC

ART.N°: 347603

FEATURES

- 4D compatible
- JR specific construction
- Padded junior highback
- Fit ankle strap

SIZES

JR



550 4D

ART.N°: 357103 550 4D
ART.N°: 357143 550 4D BOA (+COILER)

FEATURES

4D compatible • Moonwalker R Pro outsole
• Cuff cut construction • Heel frame • Rubber heelcup • Rubber toecap • Exchangeable rubber tongue guard • Top-fit liner • Polygiene treatment

SIZES

250, 255, 260, 265, 270, 275, 280, 285,
290, 295, 300, 305, 315, 325



550 4D JR

ART.N°: 357203 550 4D JR
ART.N°: 357243 550 4D JR BOA (+COILER)

SIZES

225, 235, 245



550 4D KID

ART.N°: 357303 - 550 4D KID
ART.N°: 357343 - 550 4D KID BOA (+COILER)

SIZES

195, 205, 215

500 4D

ART.N°: 357403 500 4D
ART.N°: 357443 500 4D BOA (+COILER)

FEATURES

4D compatible • Explorer outsole • Rubber covered laceguides • Injected heel section
• Rubber toecap • Easy-fit liner • Polygiene treatment

SIZES

250, 255, 260, 265, 270, 275, 280, 285, 290,
295, 300, 305, 315, 325



500 4D JR

ART.N°: 357503 500 4D JR
ART.N°: 357543 500 4D JR BOA (+COILER)

SIZES

225, 235, 245



500 4D KID

ART.N°: 357603 500 4D KID
ART.N°: 357643 500 4D KID BOA (+COILER)







SIZES

195, 205, 215

RACE

-  **WORLD CUP REBELS i.GS RD M / W** PAGE 26
-  **WORLD CUP REBELS i.GS RD** PAGE 26
-  **WORLD CUP REBELS i.DH RD** PAGE 27
-  **WORLD CUP REBELS i.SG RD** PAGE 27
-  **WORLD CUP REBELS i.SL RD** PAGE 28
-  **WORLD CUP REBELS i.SL** PAGE 29
-  **WORLD CUP REBELS i.SPEED** PAGE 29

PERFORMANCE

-  **i.SUPERSHAPE TITAN** PAGE 30
-  **i.SUPERSHAPE RALLY** PAGE 30
-  **i.SUPERSHAPE MAGNUM** PAGE 30
-  **i.SUPERSHAPE SPEED** PAGE 31
-  **PRESTIGE** PAGE 31
-  **PREMIUM** PAGE 31

ALLRIDE

-  **REV 105** PAGE 32
-  **REV 90** PAGE 32
-  **REV 85 PRO** PAGE 33
-  **REV 80 PRO** PAGE 33
-  **REV 78** PAGE 34
-  **REV 75** PAGE 34

-  **INTEGRALE 1000** PAGE 35
-  **INTEGRALE 800** PAGE 35
-  **INTEGRALE 600** PAGE 35

FREESKI







-  **TURBINE 125** PAGE 36
-  **CYLCIC 115** PAGE 36
-  **COLLECTIVE 105** PAGE 36
-  **VENTURI 95** PAGE 37
-  **PROSTELLAR 98** PAGE 38
-  **GALACTIC 84** PAGE 38
-  **NEBULA 78** PAGE 38
-  **THE CADDY** PAGE 40
-  **FRAMEWALL** PAGE 41
-  **OBLIVION** PAGE 41
-  **THE SHOW** PAGE 41

WOMEN

-  **BIG JOY** PAGE 42
-  **GREAT JOY** PAGE 43

-  **TOTAL JOY** PAGE 44
-  **SUPER JOY** PAGE 44
-  **ABSOLUT JOY** PAGE 45
-  **PURE JOY** PAGE 45

JUNIOR

-  **WORLD CUP REBELS i.SG RD** PAGE 46
-  **WORLD CUP i.GS TEAM** PAGE 48
-  **WORLD CUP i.SL TEAM** PAGE 48
-  **WORLD CUP i.RACE TEAM** PAGE 49
-  **SUPERSHAPE LR** PAGE 49
-  **SUPERSHAPE TEAM LR** PAGE 49
-  **ETHAN TOO** PAGE 50
-  **THE JR CADDY** PAGE 50
-  **RESIDUE** PAGE 50
-  **FIRST JOY** PAGE 51
-  **SOUPHEAD LR** PAGE 51
-  **PEZ TEAM** PAGE 51

RACE



RAPTOR B2 RD
PAGE 60



VECTOR 115
PAGE 65



CUBE3 10
PAGE 68



RAPTOR 110 RS W
PAGE 71



NEXT EDGE 80 W
PAGE 74



RAPTOR 70
PAGE 77



EDGE J 2
PAGE 79



RAPTOR B3 RD
PAGE 60



VECTOR 105
PAGE 65



CUBE3 8
PAGE 68



CHALLENGER 110 W
PAGE 71



NEXT EDGE 70 W
PAGE 74



RAPTOR 50
PAGE 77



EDGE J 1
PAGE 79



RAPTOR 130 RS
PAGE 61



ADAPT EDGE 110
PAGE 66



RAPTOR OVERKILL
PAGE 69



VECTOR 105 W
PAGE 71



CUBE3 12 W
PAGE 75



RAPTOR 40
PAGE 77



RAPTOR 115 RS
PAGE 61



ADAPT EDGE 100
PAGE 66



VENTURE ATX
PAGE 69



DREAM 100 W
PAGE 72



CUBE3 10 W
PAGE 75



RAPTOR CADDY 50 JR
PAGE 78

PERFORMANCE



CHALLENGER 130
PAGE 64



ADAPT EDGE 90
PAGE 66



VENTURE 130
PAGE 69



DREAM 90 W
PAGE 72



CUBE3 8 W
PAGE 75



RAPTOR CADDY 40 JR
PAGE 78



CHALLENGER 120
PAGE 64



NEXT EDGE 80
PAGE 67



RAPTOR OBLIVION
PAGE 70



DREAM 80 W
PAGE 72

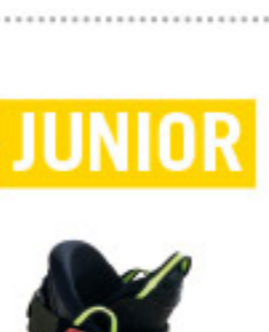

RAPTOR B5 RD
PAGE 76



SOUP HEAD 2
PAGE 78



CHALLENGER 110
PAGE 64



NEXTEGE 70
PAGE 67



THE SHOW 1
PAGE 70



ADAPT EDGE 100 W
PAGE 73



RAPTOR 90 RS
PAGE 76



SOUP HEAD 1
PAGE 78



VECTOR 125
PAGE 65



CUBE3 12
PAGE 68



THE SHOW 2
PAGE 70



ADAPT EDGE 90 W
PAGE 73



RAPTOR 80 RS
PAGE 76



EDGE J 3
PAGE 79

WOMEN



RAPTOR 110 RS W
PAGE 71



NEXT EDGE 80 W
PAGE 74



RAPTOR 70
PAGE 77



EDGE J 2
PAGE 79



CHALLENGER 110 W
PAGE 71



NEXT EDGE 70 W
PAGE 74



RAPTOR 50
PAGE 77



EDGE J 1
PAGE 79



VECTOR 105 W
PAGE 71



CUBE3 12 W
PAGE 75



RAPTOR 40
PAGE 77



DREAM 100 W
PAGE 72



CUBE3 10 W
PAGE 75



RAPTOR CADDY 50 JR
PAGE 78



DREAM 90 W
PAGE 72



CUBE3 8 W
PAGE 75



RAPTOR CADDY 40 JR
PAGE 78

JUNIOR



RAPTOR B5 RD
PAGE 76



SOUP HEAD 2
PAGE 78



RAPTOR 90 RS
PAGE 76



SOUP HEAD 1
PAGE 78



RAPTOR 80 RS
PAGE 76



EDGE J 3
PAGE 79

RACE



FREEFLEX PRO 20 X RD
ART.N°: 100500



FREEFLEX PRO 20 X RS
ART.N°: 100501



FREEFLEX PRO 18 X
ART.N°: 100502



FREEFLEX PRO 16 X RD/EP
ART.N°: 100505



FREEFLEX PRO 16
ART.N°: 100506



FREEFLEX PRO 14
ART.N°: 100508



FREEFLEX PRO 11
ART.N°: 100510

PERFORMANCE



PRD 14 S
ART.N°: 100513
PRD 14 S BRAKE 88 [F]
ART.N°: 100514



PRD 14
ART.N°: 100430



PRX 12 S
ART.N°: 100522
PRX 12 S BRAKE 88 [F]
ART.N°: 100523

ALLRIDE



PRD 12
ART.N°: 100520
PRD 12 BRAKE 88 [F]
ART.N°: 100521



PR 11
ART.N°: 100566
ART.N°: 100384
ART.N°: 100568
ART.N°: 100567 BRAKE 90 [G]
ART.N°: 100527
ART.N°: 100528



TYROLIA LRX 9.0
ART.N°: 111637
ART.N°: 111526

FREESKI



AAADRENALIN 16 SHORT
ART.N°: 111604 w/o BRAKE [B]
AAADRENALIN 16 LONG
ART.N°: 111605 w/o BRAKE [B]



AAADRENALIN 13 SHORT
ART.N°: 111606 w/o BRAKE [F]
AAADRENALIN 13 LONG
ART.N°: 111607 w/o BRAKE [F]



AAAMBITION 12
ART.N°: 111612 w/o BRAKE [C]
ART.N°: 111610 w/o BRAKE [C]



AAAMBITION 10
ART.N°: 111716 w/o BRAKE [C]



AAATTACK 16
ART.N°: 111615 w/o BRAKE [A]



AAATTACK 13
ART.N°: 111616 BRAKE 97 [A]
ART.N°: 111618 w/o BRAKE [A]
ART.N°: 111617 w/o BRAKE [A]



AAATTACK 13 DEMO
ART.N°: 111721 w/o BRAKE [D]



TYROLIA PEAK 18 X
ART.N°: 111620 w/o BRAKE [A]

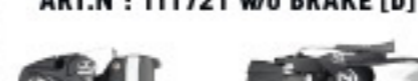

TYROLIA PEAK 11
ART.N°: 111624 BRAKE 90 [E]
ART.N°: 111726 w/o BRAKE [E]

WOMEN



AAATTACK 12
ART.N°: 111722



JOY 11 SLR
ART.N°: 100573 BRAKE 90 [H]
ART.N°: 100574



JOY 9 SLR
ART.N°: 100575 BRAKE 90 [H]
ART.N°: 100576



LRX 4.5 AC/JOY 4.5 AC LRX
ART.N°: 100441
ART.N°: 100572

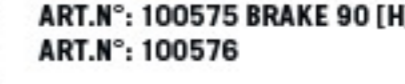

PEAK 7.5 AC BRAKE 90 [J]
ART.N°: 111627



PEAK 4.5 AC BRAKE 84 [K]
ART.N°: 111628



TYROLIA SX 7.5 AC
ART.N°: 111654
ART.N°: 111549



TYROLIA SX 4.5 AC
ART.N°: 111554
ART.N°: 111555
ART.N°: 111556
ART.N°: 111557
ART.N°: 111569



TYROLIA SX 4.5 AC
ART.N°: 111554
ART.N°: 111555
ART.N°: 111556
ART.N°: 111557
ART.N°: 111569

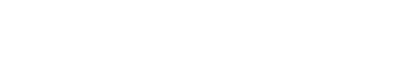

TYROLIA SX 4.5 AC
ART.N°: 111554
ART.N°: 111555
ART.N°: 111556
ART.N°: 111557
ART.N°: 111569



TYROLIA SX 4.5 AC
ART.N°: 111554
ART.N°: 111555
ART.N°: 111556
ART.N°: 111557
ART.N°: 111569



TYROLIA SX 4.5 AC
ART.N°: 111554
ART.N°: 111555
ART.N°: 111556
ART.N°: 111557
ART.N°: 111569



TYROLIA SX 4.5 AC
ART.N°: 111554
ART.N°: 111555
ART.N°: 111556
ART.N°: 111557
ART.N°: 111569



TYROLIA SX 4.5 AC
ART.N°: 111554
ART.N°: 111555
ART.N°: 111556
ART.N°: 111557
ART.N°: 111569



TYROLIA SX 4.5 AC
ART.N°: 111554
ART.N°: 111555
ART.N°: 111556
ART.N°: 111557
ART.N°: 111569



TYROLIA SX 4.5 AC
ART.N°: 111554
ART.N°: 111555
ART.N°: 111556
ART.N°: 111557
ART.N°: 111569

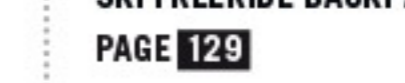

TYROLIA SX 4.5 AC
ART.N°: 111554
ART.N°: 111555
ART.N°: 111556
ART.N°: 111557
ART.N°: 111569



TYROLIA SX 4.5 AC
ART.N°: 111554
ART.N°: 111555
ART.N°: 111556
ART.N°: 111557
ART.N°: 111569



TYROLIA SX 4.5 AC
ART.N°: 111554
ART.N°: 111555
ART.N°: 111556
ART.N°: 111557
ART.N°: 111569



TYROLIA SX 4.5 AC
ART.N°: 111554
ART.N°: 111555
ART.N°: 111556
ART.N°: 111557
ART.N°: 111569



TYROLIA SX 4.5 AC
ART.N°: 111554
ART.N°: 111555
ART.N°: 111556
ART.N°: 111557
ART.N°: 111569



TYROLIA SX 4.5 AC
ART.N°: 111554
ART.N°: 111555
ART.N°: 111556
ART.N°: 111557
ART.N°: 111569



TYROLIA SX 4.5 AC
ART.N°: 111554
ART.N°: 111555
ART.N°: 111556
ART.N°: 111557
ART.N°: 111569

RACE



WORLDCUP SUPER G
PAGE 132



WORLDCUP SL
PAGE 132



WORLDCUP SL
PAGE 132

PERFORMANCE



SUPERSHAPE VIP
PAGE 132



CARBON PRESTIGE
PAGE 132



HEAD CLASSIC
PAGE 133



HEAD CLASSIC
PAGE 133



HEAD CLASSIC
PAGE 133

ALLRIDE



MULTI S
PAGE 134



MULTI S
PAGE 134



MULTI S
PAGE 134



MULTI S
PAGE 134

FREESKI



3350 VARIO TWO PIECE
PAGE 135



3312 VARIO THREE PIECE
PAGE 135



AERO
PAGE 135

WOMEN



JOY WHITE
PAGE 136



JOY BLACK
PAGE 136

JUNIOR



WORLDCUP SG JR
PAGE 137



SUPERSHAPE TEAM
PAGE 137



AERO TEAM
PAGE 137



JOY GIRL
PAGE 137

RACE



REBELS TRAVELBAG
PAGE 124

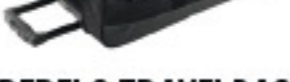

REBELS BACKPACK
PAGE 124



REBELS RACING BACKPACK
PAGE 124



REBELS DOUBLE SKI BAG
PAGE 125

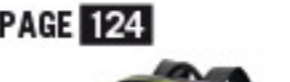

REBELS HEATABLE BOOT BAG
PAGE 125



REBELS DOUBLE SKI BAG
PAGE 125

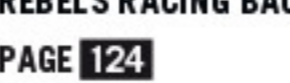

REBELS DOUBLE SKI BAG
PAGE 125



REBELS DOUBLE SKI BAG
PAGE 125



REBELS DOUBLE SKI BAG
PAGE 125



REBELS DOUBLE SKI BAG
PAGE 125



REBELS DOUBLE SKI BAG
PAGE 125



REBELS DOUBLE SKI BAG
PAGE 125



REBELS DOUBLE SKI BAG
PAGE 125

ALLRIDE



SKI DAYPACK
PAGE 126



SKI DAYPACK
PAGE 126



SKI DAYPACK
PAGE 126

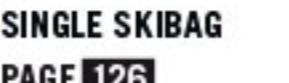

SKI DAYPACK
PAGE 126



SKI DAYPACK
PAGE 126



SKI DAYPACK
PAGE 126



SKI DAYPACK
PAGE 126



SKI DAYPACK
PAGE 126



SKI DAYPACK
PAGE 126



SKI DAYPACK
PAGE 126



SKI DAYPACK
PAGE 126

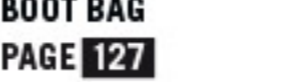

SKI DAYPACK
PAGE 126



SKI DAYPACK
PAGE 126

FREESKI



FREERIDE SINGLE BAG
PAGE 128



FREERIDE SINGLE BAG
PAGE 128



FREERIDE SINGLE BAG
PAGE 128



FREERIDE SINGLE BAG
PAGE 128

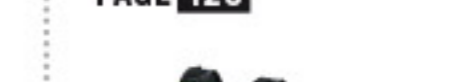

FREERIDE SINGLE BAG
PAGE 128



FREERIDE SINGLE BAG
PAGE 128

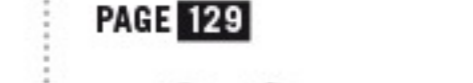

FREERIDE SINGLE BAG
PAGE 128



FREERIDE SINGLE BAG
PAGE 128

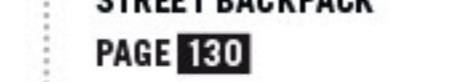

FREERIDE SINGLE BAG
PAGE 128



FREERIDE SINGLE BAG
PAGE 128



FREERIDE SINGLE BAG
PAGE 128



FREERIDE SINGLE BAG
PAGE 128



FREERIDE SINGLE BAG
PAGE 128

WOMEN



TRAVELBAG SM
PAGE 130



TRAVEL DUFFLE BAG
PAGE 130



TRAVEL DUFFLE BAG
PAGE 130



TRAVEL DUFFLE BAG
PAGE 130



TRAVEL DUFFLE BAG
PAGE 130



TRAVEL DUFFLE BAG
PAGE 130



TRAVEL DUFFLE BAG
PAGE 130



TRAVEL DUFFLE BAG
PAGE 130

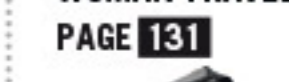

TRAVEL DUFFLE BAG
PAGE 130



TRAVEL DUFFLE BAG
PAGE 130



TRAVEL DUFFLE BAG
PAGE 130



RACE



STIVOT RACE CARBON
PAGE 104



STIVOT SL + CHINGUARD
PAGE 104

PERFORMANCE



ALPHA BT RUNTASTIC
PAGE 105



ALPHA
PAGE 105

ALLRIDE



SENSOR
PAGE 106

FREESKI



CREST
PAGE 106



AGENT
PAGE 107



REBEL
PAGE 107

WOMEN



ADORE
PAGE 108



CARMA
PAGE 109



GRACE
PAGE 109



AVRIL
PAGE 110



CLOE
PAGE 110

JUNIOR



STIVOT RACE YOUTH CARBON
PAGE 111



STIVOT YOUTH SL + CHINGUARD
PAGE 111



JOKER
PAGE 112



STAR
PAGE 112

RACE



HORIZON RACE
PAGE 114

PERFORMANCE



STIVOT
PAGE 115

ALLRIDE



SPARK
PAGE 115



NUKE
PAGE 115

FREESKI



HORIZON
PAGE 116



SPARK
PAGE 116



NUKE
PAGE 116

WOMEN



HORIZON WOMEN
PAGE 117



STIVOT WOMEN
PAGE 117

JUNIOR



NINJA
PAGE 117

RACE



FLEXOR UNIT RACE
PAGE 119

ALLRIDE



FLEXOR UNIT
PAGE 119

JUNIOR



FLEXOR JR UNIT RACE
PAGE 121



FLEXOR JR UNIT
PAGE 121

PERFORMANCE



FLEXOR VEST
PAGE 120

WOMEN



FLEXOR WMN VEST
PAGE 120



FLEXOR JR VEST
PAGE 121

TECHNOLOGY FEATURES SKI

AIRCOAT SUPERLIGHT TWINTIP CONSTRUCTION: For kids who want to spin their first 7, we found the perfect fiberglass for catching air - Aircoat. This twin tip construction is designed specifically for the lighter weight skier to become the skier of tomorrow.

ALLRIDE ROCKER: Rocker that is equally at home on bulletproof snow as it is in powder. This profile uses early rise in the tip with regular camber throughout the rest of the ski. 20% rocker - 80% camber.

DIECUT UHM C BASE: This durable workhorse base material is dedicated to all country skiing. Diecuts are added for flare.

DIFFUSOR: Ridges in the tail of tail of our skis that direct skis that direct energy to the end of the ski. Like the diffusor on cars, this sticks the ski into the snow at the end of the turn and boosts skiers all over the mountain.

E BASE BLACK: Basic black never goes out of style, and it's always durable. Easy gliding is everyone's friend.

ERA 2.0: ERA 2.0 is the little brother of ERA 3.0 and is everything 3.0 has to offer as far as design, performance and geometry integration, but without the addition of "Rebound" with its piezoelectric Intellifibers.

ERA 3.0: A masterful blend of three independently important technologies to make the ultimate allcountry skis.
ROCKER + RADIUS + REBOUND = ROCKER DONE RIGHT.

ERA 3.0 S : "Sports version" of ERA 3.0 with a multifaceted ski designed with race innovation and inspiration, yet now with the addition of Rocker, Radius and Rebound. Totally new skiing experience with 10% rocker and 90% camber.

HIGHLY TRANSPARENT UHM BASE: A high-density, determinedly durable base that allows gorgeous graphic details to shine through. The perfect combination of fashion and function.

INTELLIGENCE™ TECHNOLOGY: Piezoelectric fibers that absorb vibrations at the speed of light. As you ski faster, the Intelligence™ stiffens the ski to increase stability. It adapts to where and how you ski.

INTELLIGENCE™ CHIP TECHNOLOGY: With Intelligence™ Chip Technology the electrical energy produced by the Intellifibers is not just recycled but accumulated and released bit by bit through a pre-programmed chip.

ISS – INDEPENDENT SUSPENSION SYSTEM: Elastomeric vibration killers located in the tip, tail and underfoot. The elastomers quiet the vibrations that are commonly associated with rockered skis. Underfoot, the vibrations are dampened to provide the skier with a smooth ride.

JUNIOR POWER FRAME: A geometric ski shape that provides structural strength to the outer edges of the ski through geometric design, as opposed to altering the core material or density of the ski. Also, for kids it looks cool and feels different than a standard flat ski.

KERS: A computerized piezoelectronic device that stores ski energy and releases it at the end of each turn. In reality, it's a turbo charger for your skis.

METAL POWER TUBES: Premium features for premium skis. Metal power tubes enable a perfect power transmission from edge to edge. Maximum performance and grip right underneath your foot. Just as you want it!

NANO TECH SURFACE: A permeable nonstick surface with similar molecular compounds and structure to that of a skis base material. This allows you to wax and alter the surface with standard ski wax to assure a lightweight nonstick and snow free surface for your trek up.

PNP ROCKER: Very subtle tip and tail rise with regular camber construction underfoot. PNP Rocker provides a rider a smother turn initiation as well as reduced edge contact to seamlessly butter into tricks and initiate spins. 30% rocker and 70% camber.

POWER CARBON JACKET: A PU injected core that is wrapped in a layer of carbon fibers. This lightweight construction allows for a soft longitudinal flex coupled with a stiff, responsive torsional flex. It delivers an easy-to-use but impressively responsive ski.

POWER SIDEWALL JACKET: An innovation in ski construction that combines the well known fiber jacket construction with ABS sidewalls. A lightweight ski with easy skiing performance including sidewalls for better dampening, shock absorption and edge grip. Performance at its best for its great target group.

RACE STRUCTURED UHM C BASE: The highest quality, fastest base and finish known to man. The technicians who build the skis for our World Cup Rebels use the same material and machines to put this scary fast base and structure into your skis.

RD RACING TOP SHEET: A thinner topsheet material designed to maximize responsiveness. Exclusive to our RD skis.

REBEL CAMBER: Some years ago it was years ago, it was rebellious to have rocker. Now, it's rebellious to have camber. With Rebel Camber, we feature explosive acceleration and excellent edge grip for the World Cup Rebel inside you.

SANDWICH CAP CONSTRUCTION: We take the basic framework from the world cup sandwich and place a cap that just wraps over the top edge of the sidewall to make the ski more suitable for all mountain skiing. Bomber construction with a rounded top edge makes for one incredible allcountry ski.

SANDWICH TWINTIP CONSTRUCTION: We blend a full vertical laminate wood core for durability and add our bomber Independent Suspension System for killing chatter. Pipe, park, big mountains, whatever, bring 'em on and let this construction rip.

STRUCTURED SURFACE: An extra-durable topsheet with a structured exterior. Designed to hold up against the most extreme abuse.

STRUCTURED UHM C BASE: The same high quality material used in HEAD's world-leading race skis is used here. Different structured running base for all conditions.

TNT ROCKER: Tip and tail rocker combined with regular camber underfoot. This combination creates a surfy feel in powder while maintaining hard snow versatility. 40% rocker - 60% camber.

TTS (TIP & TAIL STABILIZER SYSTEM): A ski with reduced vibration and increased dampening and a system to increase torsional strength all while at the same time reducing swing weight.

TUFFWALLS: Impact resistant ABS sidewalls. While maintaining responsiveness, Tuffwalls are designed to take a beating

TWINTIP CONSTRUCTION: A vertically laminated wood core, surrounded by a sock of fiberglass and covered by a durable topsheet. This forgiving twin tip construction is slightly softer than our sandwich twin tip layup, making it better for learning pipe and park tricks.

UHM C BASE: Our highly durable base material for getting the job done well. Not flashy, but steady and stable. The kind of base that will last for years.

WOOD CORE CAP CONSTRUCTION: A vertically laminated wood core, surrounded by a sock of fiberglass and covered by a durable topsheet. This forgiving construction is slightly softer than our sandwich cap making it ideal for ramping up the learning curve.

WORLD CUP SANDWICH CONSTRUCTION: The basic construction invented by Howard Head in the 1940's, perfected and hand built by the finest ski technicians in the modern world. The vertical laminate wood core is embraced by speedfreak phenolic sidewalls and the finest Titanal. This is the fastest construction on the planet. Period.

TECHNOLOGY FEATURES BINDINGS

ABS – ANTI BLOCKING SYSTEM: The exclusive TYROLIA technology of the ABS continuous band allows the boot to move out of the binding almost without any friction, hence delivering maximum safety in case of icing up, dirt and boot wear.

AERO TOE: The Performance Toe which is used in alpine ski racing. Due to higher release forces vertically than horizontally these toes hold up to the high backward lean forces occurring in racing. Our athletes trust in them!

AFS – ANTI FRICTION SLIDER: New weight optimized adapter for gliding insert at Power Bindings for reduced friction, constant release values and maximum safety.

AFS JUNIOR: The innovative mechanical Anti Friction Slider (AFS) automatically adjusts to the boot sole height, compensating A/C standards as well as height differences due to icing up, dirt or boot wear.

AFS METAL: The 68 mm wide slider plus a stainless steel gliding element provides constant release values and results in a broader contact area to the ski boot sole.

AT TOE: The Alpine Touring (AT) Toe can be easily adjusted to alpine and touring boot norms and it secures constant release values also with rubber soles.

BRAKES: HEAD offers brakes with different width for optimal fit on wider skis and fat skis up to 150 mm ski width in the brake area. Some binding models are delivered without brake – “w/o brake” – to avoid brake exchange later on.

CLIMBING AID: The climbing aid with its different climbing positions, which can be operated without stepping out of the binding, provides excellent balance and effortless climbing.

DURA-COATING: Scratch resistant electrostatic powder coating provides environmentally friendly design, optimal durability and a variety of possible colors and color combinations.

FREEFLEX PRO: Best performance enabled by the innovative Freeflex Pro System. The free-gliding heel allows the ski to bend through unimpeded and to retain its natural dynamics. Due to the reduced stand height, the Freeflex band is now much closer to the ski boot. Constant release values reduce the risk of injury and ensure safe ski steering.

FR PRO TOE: The Freeride (FR) Pro Toe can be easily adjusted to different boot sole heights. Its horizontal spring reflects the modern architecture of the AAA-Series.

FULL DIAGONAL: Intelligent 180° release both horizontally and vertically of the Diagonal Toe and therefore ensures maximum safety in backward twisting-fall situations.

LIGHT DIAGONAL HEEL: The Light Diagonal Heel provides maximum safety with a 150° release. Thus, pressure on the knee and ligaments upon twisting forward falls and the risk of injury are reduced.

LITERAIL: LiteRail is the ultimate system for both retail and the rental sector as well. LiteRail is demo suitable, high end Rental suitable, season rental suitable and can be used for all flat skis. Due to three different mid parts, LiteRail covers boot sole lengths ranging from 199 to 347 mm. Covering this large mounting range LiteRail is perfectly suited for kids, juniors as well as adults.

LX TOE: The performance oriented LX toe defines stability and power, much as a strong and tough bull would extremely durable and absolutely reliable.

POWERRAIL: The unrivalled technology for retail, demo & rental by the well-received rail system on a modular basis provides easiest handling, maximum flexibility, optimized performance, perfect match, more stability and durability.

RACE DIAGONAL: Diagonal Toe tuned for racing purposes. Due to its higher release force vertically than horizontally, it holds up to the high backward lean forces in racing.

RACE LITE HEEL: The lighter variant of the Race Pro Heel for young up-and-comers and speed stars of tomorrow.

RACE PRO HEEL: The stand height was reduced according to the actual FIS rules. An increased contact area reduces friction and provides constant forward pressure in all skiing situations.

SL LITE HEEL: Weight optimized toe for junior and light-weight skiers with proven safety features of the HEAD/TYROLIA binding technology.

SOLID COLORED: Solid colored plastic parts are not coated with a separate color layer. Instead, the color has been added to the plastic granulate already. Thus, those parts are absolutely scratch resistant and durable but less color options are available.

SX HEEL: Based on new kinematics the ski boot is precisely secure in the binding. This ensures exact and more direct power transmission from boot to edge.

SX JR. HEEL: The new junior heel with improved kinematics to increase safety and performance for junior skiers.

SX JUNIOR TOE: The innovative kinematics of HEAD's LX and SX adult line provide advantages in performance and stability for the SX Junior line for young speedsters as well.

SX KID HEEL: The SX Kid heel provides the little ones with the best in the latest technologies and safety standards for binding innovation and integrates the new kinematics for the younger set, too. Because safety is paramount, always.

SX KID TOE: With the SX kid toe for up-and-comers and integrated innovative LX/SX kinematics ski steering now requires even less effort.

SX TOE: The kinematic improvements are reflected in the product design of the SX toe as well. With its high cheek bones it reminds of a fox – smart, spry, agile and very clever.

TEFLON WIDE: The wide Teflon® insert ensures better force transmission, more stability and therefore optimal performance.

TELESCOPIC TUBE: With only one binding model it is possible to cover the entire range of different sole lengths (from 260 mm up to 350 mm).

TRP – TYROLIA ROLLER PINCER SYSTEM: The TYROLIA Roller Pincer Toe System (TRP System) of the HEAD bindings with its four rollers and gliding inserts ensure a 180° release and exact centering of the ski boot. The TRP system reduces the load on knees and ligaments and improves performance considerably.

BASES/PLATES

JUNIOR RACE PLATE 11: It provides an additional stand height of 11mm and covers boot sole lengths from 251-332 mm. Oblong Holes and a two-piece flex system support Freeflex and maintain ski flexibility. It provides increased torsion stability, control and edge grip although being super light. Pre drilled mounting holes make it easier to mount the binding without drilling.

POWERRAIL PRO BASE: The high-end variant, PowerRail Pro, is equipped with an additional Freeflex band which links both toothed areas at the toe and the heel side of the base. Therefore, toe and heel piece can glide on the base unhindered. This additional “Double Freeflex Function” ensures fewer impediments of the natural ski flex, constant release values and better edge grip.

POWERRAIL STANDARD BASE: The standard PowerRail Base consists of a monoblock base body, a cover, and an inlaid toothed area which can be color matched to the ski design. For unhindered natural ski flex, the base is secured by one fixed pair of screws, and three free-gliding pairs of screws. This ensures the base safely adapts to the flex of the ski.

SPEEDFLEX PLATE: The new free gliding speedflex plate provides an additional stand height of 13 mm and the impact on ski flex is greatly reduced. Dampener, oblong holes and the new designed super flex system support Freeflex and maintain ski flexibility. Additional metal brackets provide increased edge grip, torsion stability and control.

TECHNOLOGY FEATURES BOOTS

LINERS

DOUBLE POWER BOOSTER VELCRO: The strap of the Double Power Booster Velcro works as a double pulley for better closure and a tighter wrapping on the cuff. The elastic Booster strap allows more dynamic response on the boot. The result is more precise transmission and faster ski reaction.

DOUBLE POWER VELCRO STRAP: Developed and patented by HEAD, this velcro strap uses a double-pulley system, which gives 100% more closing power, by reducing the effort needed by 50%. The length of the Double Power Velcro can be customized to "wide" or "narrow" by choosing between the internal or external ring. The result is exceptional support through the shaft of the boot.

HEATFIT (HF) LINERS: Multi-component liners with moldable inserts in liner and tongue. 5 minutes of heating, is all that is required, to make the lining adapting and get the perfect precision and comfort.

QUICK ENTRY LINERS: These liners come with a unique easy entry construction in the fore foot. Developed both for skiing and walking, Quick Entry liners always feel extremely comfortable.

PERFECT FIT (PF): Perfect Fit is the revolutionary customization system that provides the best level of precision, comfort and durability. The Perfect Fit material allows the liner to adapt to your feet, ensuring maximum power transmission. 5 minutes of heating at 80 degrees, is all that is required, to make the lining adapting and get the perfect precision and comfort.

PRO LINERS: Pro Series are thin and very supportive liners developed to assure maximum wrapping and extreme high performance. They come with a stretchy upper material, thermo-moldable ankle inserts and a rear sliding insert.

BUCKLES

DOUBLE POWER LEVER:

The Double Power lever reduces the effort needed to close the buckle by 50%. Developed and patented by HEAD.

DOUBLE POWER SPINEFLEX BUCKLE:

Spineflex buckle featuring Double Power lever.

DOUBLE POWER SPINE-TECH BUCKLE:

Spine-tech buckle featuring Double Power lever.

SPINEFLEX BUCKLE: A revolutionary buckle concept with a flexible element and a constant closure point. The flexible element allows the buckle to adapt to the shell profile. The constant closure point increases the overlap between the shell flaps and reduces pressure points. The increased comfort and precision results in better performance.

SPINE-TECH BUCKLE: The Spine-Tech buckle features a constant traction closure point. This translates into a reduction in pressure points, an increased overlap between shell flaps, more comfort, and more precision.

SUPERMACRO RATCHET:

An adjustable, ratcheted toothplate that provides 28 mm of calf-adjustment.

WIDE-BODY BUCKLE:

Oversize buckle designed for an extreme ease of use. The fastest way to close the boot's cuff.

FEATURES

ADAPTIVE FIT TECHNOLOGY:

HEAD patented mechanism in the sole which allows the user to change the width of the boot from 104 to 102mm with one turn of a screw.

ADJUSTABLE REAR SPOILER:

Height adjustable spoiler increases rearward support as it's raised.

ADJUSTABLE WEDGE ARCH SUPPORT:

Internal wedge with ON-OFF mechanism customizing the arch of the foot depending on its anatomy.

DOUBLE ADJUSTABLE PROFILE: A double mechanism in the upper rear part of the boot which adapts the circumference of the cuff up to 1 cm to fit individual anatomical needs. Located on the either side of the cuff's spine, this mechanism allows the cuff to adjust up to 1 cm to better fit the anatomical needs of skier.

EASY ENTRY SHELL CONSTRUCTION:

Front plate easy opening construction to let the youngest get in smoothly.

EASY ENTRY SHELL DESIGN: Located in the throat of the boot, 4 channels are cut into the plastic to reduce the thickness of the material and thus provide smoother entry and better wrapping to the foot.

ENERGY FRAME: Specifically designed to reinforce the EDGE line shell structure, the Energy Frame lands more stability and performance to the boot.

TRI(BI)-INJ. FRAME:

A high performance, multi-density shell that optimizes easy entry, foot wrapping, comfort and energy transmission.

FLEX STANCE TUNING: Screw mechanism with a plate support on the spine of the cuff. By adding the screw(s) the link between shell and cuff becomes stronger and the flex of the boot stiffer. It also works as a forward lean adjuster.

FLEX TUNING: A screw mechanism on the spine of the cuff that links shell and cuff. To get a softer flex, the screw(s) can be replaced by the plastic caps included in the box.

INTEGRATED AUTOSKIWALK (ASW): HEAD patented integrated device which automatically switches between skiing and walking position when stepping in or out of the bindings.

POWER CONTROL FRAME:

Designed to reinforce the Cube 3 line shell structure in order to give more stability and performance to the boot

SKI-HIKE SYSTEM:

Is a device which allow the easiest selection of ski and hike mode available. Provides a powerful connection between the cuff and shell for maximum precision and impulse transmission while skiing.

SOFTWALK HEEL + GRIP SYSTEM: HEAD patented cushion positioned in the heel for shock absorption and smoother heel striker, without compromising the performance. The grip system is a rubber insert which provides grip for walking on slippery surfaces.

STIFFER/SOFTER FLEX ADJUSTMENT: It's an adjustment placed on the spine of the cuff to select between a stiffer or softer flex depending on snow condition and level of skiing.

SHOCK ABSORPTION WEDGE:

A rubberized boot board that allows for smoother riding over varied terrain and shock-free landings.

VIBRAM SOLE:

The bi-injected Vibram® sole allows safe hiking on all terrain while reducing shock absorption as well.

WOMEN SPECIFIC SUPPORTIVE HEEL OPTION:

A heel lift developed exclusively for women to be placed into the boot for optimized heel retention and maximum comfort.

**WHAT'S
YOUR
LIMIT?**

HEAD UNITS

AUSTRIA

HEAD Austria GmbH
Tyroliaplatz 1
2320 Schwechat
Austria
T. +43 1 701 79 0
E. info@at.head.com

CANADA

HEAD Canada Inc
P.O. Box 3620
Station Main
Guelph, Ontario N1H 7H1
Canada
T. +1 519 822 15 76
E. info@ca.head.com

FRANCE

HEAD France
ZA les Condamines
Bresson BP 29
38320 Eybens
France
T. +33 476 62 69 00
E. standard@fr.head.com

GERMANY

HEAD Germany GmbH
Velaskostr. 8
85622 Feldkirchen
Germany
T. +49 89 90 99 95 0
E. info@de.head.com

ITALY

HEAD International
c/o MARES SPA
Salita Bonsen, 4
San Pietro di Novella
16035 Rapallo (GE)
Italy
T. +39 0185 201 1
E. info-head@it.head.com

JAPAN

HEAD JAPAN
3-27 Kanda-Jimbocho
Chiyoda-ku
Tokyo 101-0051
Japan
T. +81 3 3221 7921
E. sales@jp.head.com

THE NETHERLANDS

HEAD International GmbH
Plesmanstraat 1
3833 LA Leusden
The Netherlands
T. +31 630 22 81 40
E. infobenelux@head.com

POLAND

HEAD International GmbH
Ul. Rydlówka 20
30-363 Kraków
Poland
T. +48 12 255 44 12
E. info@pl.head.com

SPAIN

HEAD SPAIN S.L.
Roger 65-67 5a
08028 Barcelona
Spain
T. +34 93 409 20 80
E. info@es.head.com

SWITZERLAND

HEAD Switzerland AG
Ruessenstrasse 16
6342 Baar
Switzerland
T. +41 41 767 07 07
E. info@ch.head.com

UNITED KINGDOM

HEAD UK Ltd
2 Beezon Road
Kendal, Cumbria
LA9 6BW
UK
T. +44 15 39 72 47 40
E. info@uk.head.com

USA

HEAD USA, Inc.
3125 Sterling Circle
Suite 101
Boulder, CO 80301
USA
T. +1 800 874 3235
E. info@us.head.com

HEAD TRADE

HEAD International

HEAD International GmbH
Wuhrkopfweg 1
6921 Kennelbach
Austria
T. +43 55 74 608 0
E. trade@head.com

ARGENTINA

Sports & Adventure S.A.
T. +54 11 6320 3400
E. administracionventas@grupovieytes.com

AUSTRALIA

Rosbert International
T. +61 3 909 577 11
E. rosbert@rosbert.com.au

BELARUS

ZAO Elite Sports
T. +375 29 620 6131
E. anastasia.i@cast.by

BULGARIA

Miras-Krastevi LTD
T. +359 32 640 680
E. office@miras-sport.com

CHILE

Inver Tech Ltda
T. +56 2 681 23 08
E. pablo.zuninoerlaver@gmail.com

CZECH REPUBLIC

Aspen Sport A.S.
T. +420 2 67 28 11 11
E. info@head.cz

CHINA

MAS Ski Equipment Limited
T. +86 10 8472 0338
E. head@masl.biz

CROATIA

Alca Zagreb trgovacko d.o.o.
T. +385 1 2481 111
E. ines.kastelan@hr.alcagroup.com

DENMARK

Cool Sport AIS
Claus Ketterle
T. +45 8853 7777
E. ck@coolsport.dk

FINLAND

Oy Anglo Nordic AB
T. +358 9 4153 5300
E. tapani.vartiainen@anglo.fi

GREECE

Parnass Ski
T. +30 2670 22646
E. parnas-ski@otenet.gr

HUNGARY

WINTERSPORT Co. Ltd.
T. +36 1 437 0181
E. toth.etre@tandtsport.hu

ICELAND

Utivera EHF T/A Everest
T. +354 533 44 50
E. everest@everest.is

KAZAKHSTAN

Intelli Sport
T. +7 333 21 777 08
E. intelli.sports@gmail.com

LEBANON

Mike Sport
T. +961 1 8888 55
E. mispo@mikesport.com

MACEDONIA

Vekon Int Doel
T. +389 23 298 259
E. borce@elteh.com.mk

NEW ZEALAND

Allsports Distribution Ltd
T. +64 7 377 1033
E. info@allsports.co.nz

NORWAY

Gresvig AS
T. +47 23 35 85 00
E. christopher.rogge@gresvig.no

ROMANIA

S.C. Sport Intercom S.R.L.
T. +40 21 224 5419
E. adina@head-sport.ro

RUSSIA

Girvas Sport
T. +7 499 171 44 65
E. m.teplov@girvas.ru

SLOVAKIA

Aspen Sport SK s.r.o.
T. +421 2482 91 522
E. katarina.kollarova@head.sk

SOUTH KOREA

Alchemist
T. +82 1577 4323
E. alchemist.kr@gmail.com

SWEDEN

Interski AB
T. +46 647 5 06 10
E. micke@interski.se

TURKEY

Sportive Spor
T. +90 5302655621
E. hakant@toksozspor.com

UKRAINE

SPORT LIDER LTD.
T. +380 97 511 6510
E. denis@eltrade.com.ua

Article: 389003-EN-11DE

